



*Perforated and expanded
zinc solutions for façades*

www.elzinc.es

elZinc

Designing with elZinc®



*Durable and versatile
perforated zinc
solutions*



Perforated and expanded metal façades combine many qualities that architects can put to good use on the exterior of their projects.

Controlled transparency. The free area of the panels can be easily varied

Singularity and Character. Designs can be customised to the individual needs of the project

Light weight. elZinc screens are made from thin gauge metal and the perforation reduces their mass further while offering high mechanical strength.

Economy. Installation solutions are normally simple, and do not blow up the budget.

Practicality. Perforated zinc is readily available and easy to install.

Versatility. The perforated zinc façade can be purely decorative or form part of the overall building structure.

Easy to install. Installation solutions are often simple and economical.

Thermal comfort. Ideal for use as solar screens, they help reduce heat build-up from the sun inside buildings.

A1 fire rating: Zinc offers excellent fire resistance.

Unlike other perforated metal surfaces, **zinc does not require post-painting treatment.** Thanks to the patina it develops, it is self-protecting.

And of course sustainability – reduction in the cooling requirements of the building.

I Index

elZinc® perforated

With its ten standard patterns and three different layouts, the elZinc® standard perforated range of standard patterns provides aesthetic and functional cladding for your façades.

Pag. 07



Special perforated designs

In collaboration with Atelier d'architecture Janez Nguyen Architectes, authors of the St-Louis Hospital nursery (Paris), we have created three exclusive perforated designs.

Pag. 20



elZinc® 3d

By combining perforation technology with pressing processes, it is possible to create screens with a three-dimensional structure.

Pag. 25



elZinc® Image

By interpreting the images and converting them into perforation patterns of different densities and sizes, the architect can "draw" on the entire façade and fully customise it.

Pag. 30



elZinc® Expanded

Stylish and robust, these panels are ideal for areas requiring good aeration such as multi-storey car parks, plant rooms or industrial facilities.

Pag. 33

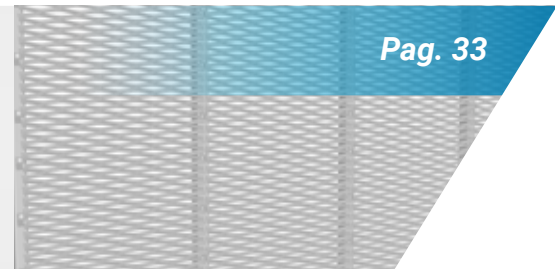

Product family	Product type	MOQ (m2)			Plastic film	Unperforated borders	Coil Standard widths	Sheet		Oil residue
		Natural	Alkimi	Rainbow				Standard widths	Standard lengths	
elZinc perforated	Standard perforated	50			Yes	Customer defined	500 1000 1330	500 1000 1330	2000 3000	Self-evaporating
	Special perforated designs	On request			Yes	Customer defined	-	According to pattern and project requirements, max. length 4000mm		Non-evaporating
	elZinc Image	Project driven			Yes	Customer defined	-	1000 1250 1330	Project defined, 6000 mm	Non-evaporating
elZinc Expanded	Large format	50			No	Not possible	-	1000 1250 1330	2000 3000	Self-evaporating
	Expanded and rolled	50			No	Not possible	1000 1250 1330	500 1000 1250 1330	2000 3000	Auto-évaporation
elZinc 3D		50			Yes	Fixed	-	1000	1000 2000	Non-evaporating

Also available in elZinc Advance on request.

See also the other available elZinc technical documents

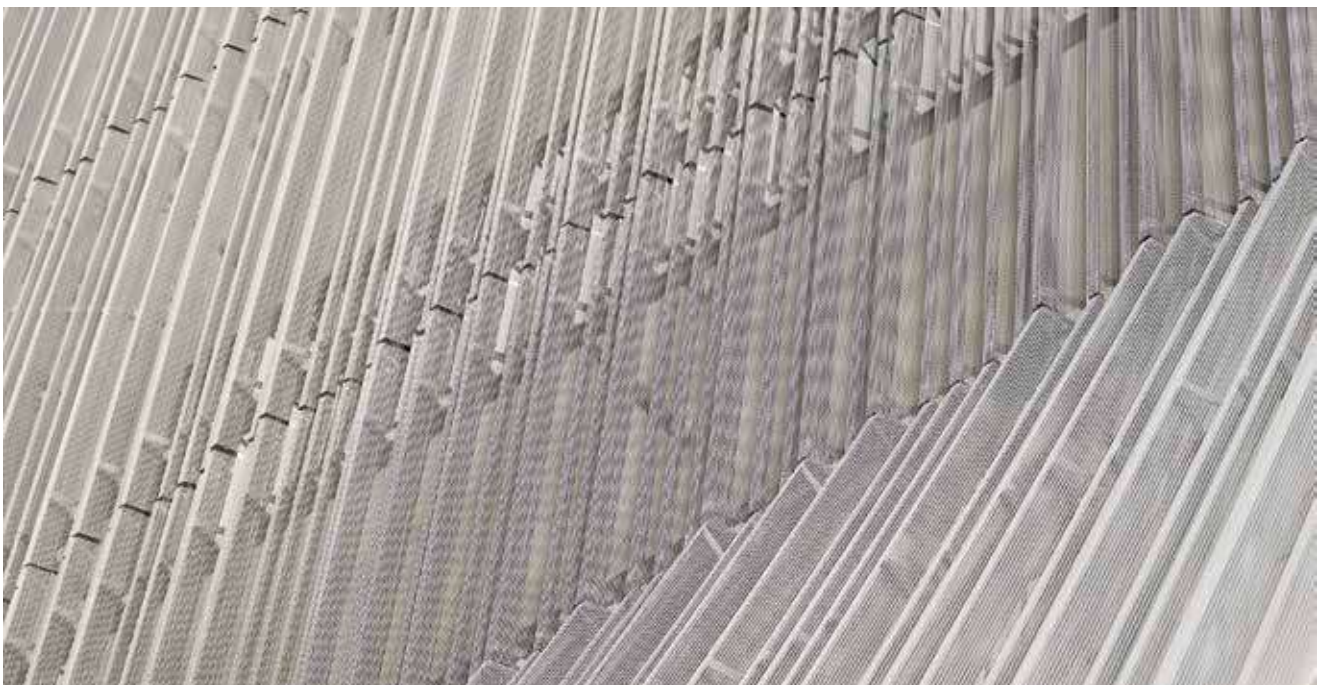

Finishes

The full range of elZinc®'s finishes are possible to perforate, expand and use for 3d panels, making a wide choice of colours available.

The base material for all perforated products is elZinc® rolled zinc, produced in accordance with EN988 and ASTM B-69, in thicknesses ranging from 0.7 mm to 1.5 mm, and in widths up to 1330 mm.

Due to the self-protective qualities of zinc, surface treatment is carried out prior to perforation. This allows more effective coil coating methods to be used during processing.

Over time a grey patina will form on the edge of the holes

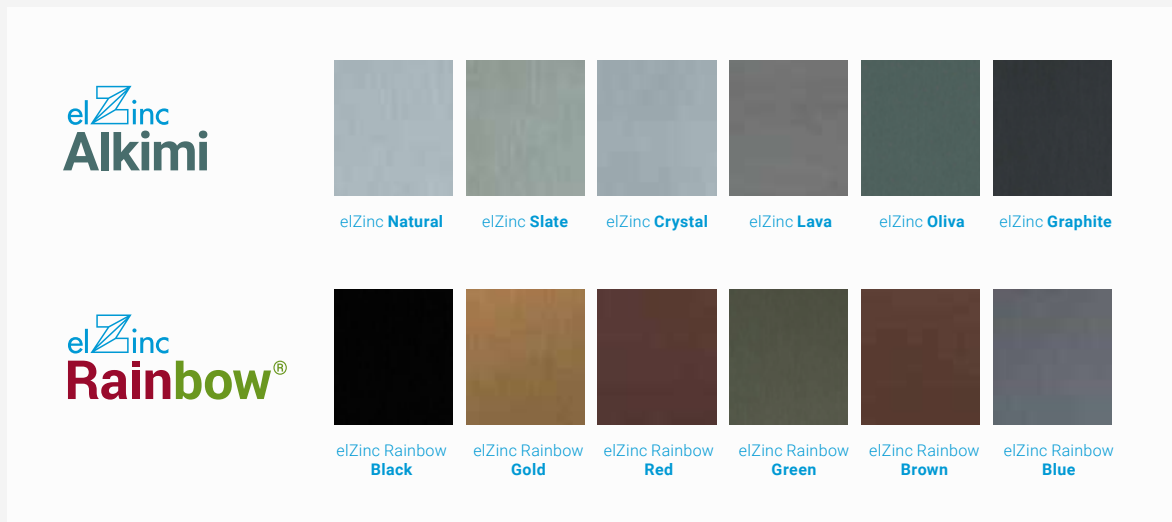

Notes : The default rear face of the elZinc Alkimi® range is the same colour as the front face. The default rear face of the elZinc Rainbow® range is elZinc Slate®. It is possible to produce elZinc Rainbow® and elZinc Advance finishes on both sides of the coil – please consult us in these cases.



elZinc® perforated façades

elZinc® is available to be used in perforated façades in 10 standard patterns, and in three different layouts. The standard patterns free area ranges from 9% to 51%, hole diameter from 3mm to 10mm. When combined with the various installation possibilities, whether formed into cassette panels, corrugated profiles or flat veils, the screening possibilities that can be incorporated into the building envelope are numerous indeed.

Patterns standard perforation

RWTP Format

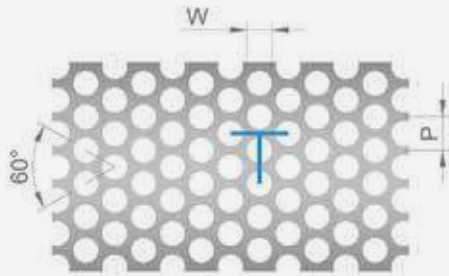

W: Perforation diameter
P: Center distance

< Coil direction

Format RWPT	Free area, %	Sheet weight, kgs/m2. No borders			
		0,7mm	0,8mm	1mm	1,5mm
R3 T4	51,0	2,47	2,82	3,53	-
R4 T6	40,3	3,01	3,44	4,30	6,45
R5 T7	46,3	2,71	3,09	3,97	5,80
R6 T9	40,3	3,01	3,44	4,30	6,45
R8 T11	48,0	2,62	3,00	3,75	5,62
R10 T14	46,3	2,71	3,09	3,87	5,80

RWMP Format

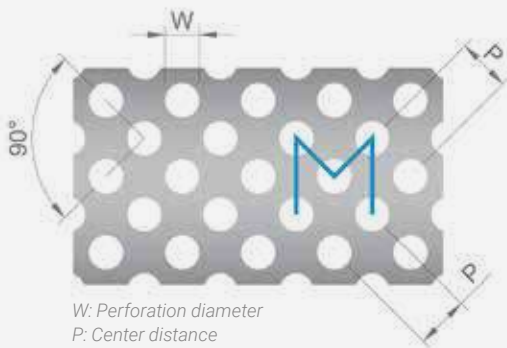

W: Perforation diameter
P: Center distance

< Coil direction

Format RWMT	Free area, %	Sheet weight, kgs/m2. No borders		
		0,7mm	0,8mm	1mm
R4 M6,22	32	3,4	3,89	4,86

Format RWUP

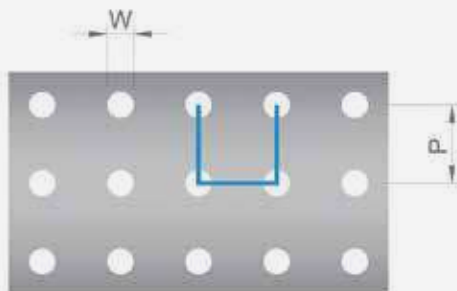

W: Perforation diameter
P: Center distance

< Coil direction

Format RWUP	Free area, %	Sheet weight, kgs/m2. No borders			
		0,7mm	0,8mm	1mm	1,5mm
R3 U8,8	9	4,58	5,23	6,54	9,81
R5 U13	12	4,45	5,09	6,36	9,55
R10 U24,4	13	4,36	4,99	6,23	9,35

Borders of standard perforated patterns

Edges of perforated eZinc supplied in coils: Coils are supplied with an unperforated border along both edges. A target width of the border is requested by the customer. Its exact width is determined by calculating the best fit of the perforation pattern within the coil width that gives the closest border width to that requested. The right hand side border can be made equal to the left hand side border, or set differently.

Edges of perforated eZinc supplied in sheets: Longitudinal edges are supplied with an unperforated border as standard, the width of which is determined in the same way as coils. Unperforated longitudinal edges are available on request.

$$\text{LHS border} + \text{RHS border} = \text{coil width} - W - (\text{number of columns of holes} - 1) \times \text{holes ctrs}$$

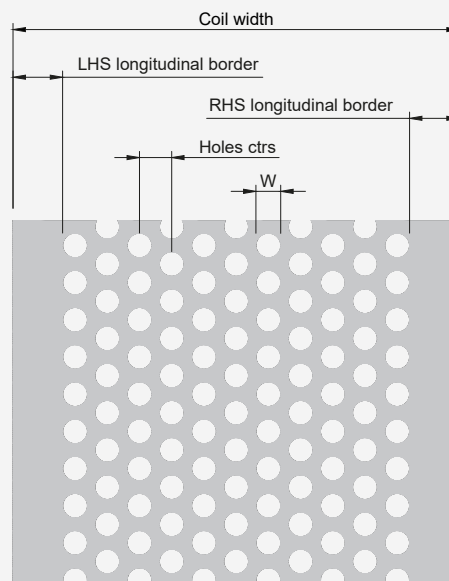

$$\text{Top border} + \text{bottom border} = \text{sheet length} - W - (\text{number of row of holes} - 1) \times \text{hole pitch}$$

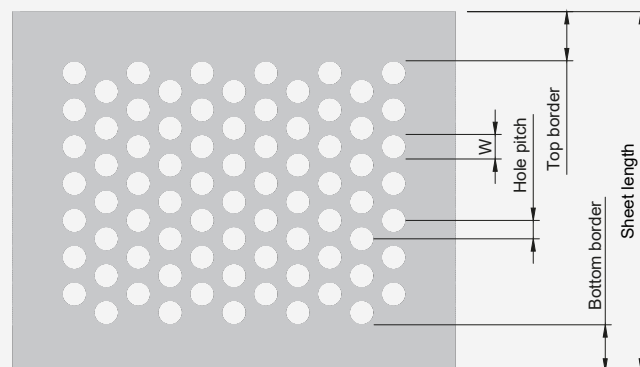

Delivery formats

The standard round perforated elZinc® is available in the following standard formats:

Format	Width (mm)	Length (mm)	Thickness
Coil	500	Depends on thickness	0,7mm 0,8mm 1,00mm 1,50mm
	1000		
	1330		
Sheet	500	2000 and 3000	
	1000		
	1330		

Other widths and lengths available on request.

Finishes

The full range of elZinc® finishes is available in all of the patterns.

Other information

The material is supplied with protective foil on one side.

Due to the self-protective qualities of zinc, the surface treatment is performed before perforation. This allows the use of more efficient coil coating methods during processing. On the edge of the holes a gray patina will form over time.

Installation ideas

Direct fixed perforated panels (visible fixings)

Can be installed horizontally or vertically.
The perimeters can be left free of perforation to create a frame around each panel, or the perforation can be taken around the panel edges.
Maximum length 4000mm.

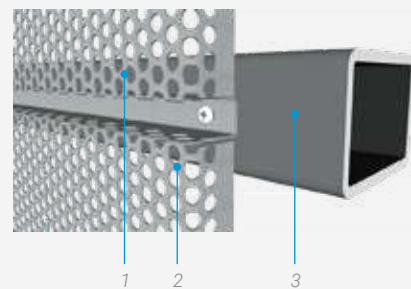
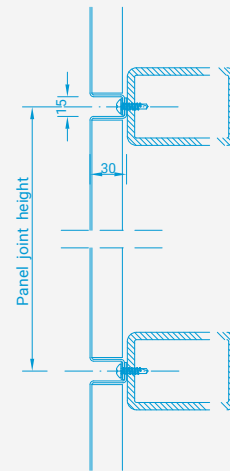

1. Perforated panel
2. Panel flange (perforated)
3. Structure

Perforation on the edges of the panel

Installation ideas

Direct fixed perforated panels (hidden fixings)

Can be installed horizontally or vertically
 The perimeters can be left free of perforation to create a frame around each panel, or the perforation can be taken around the panel edges.



No perforation on the edges of the panel

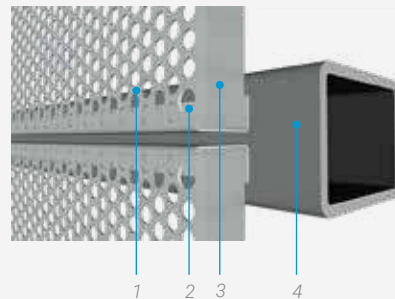
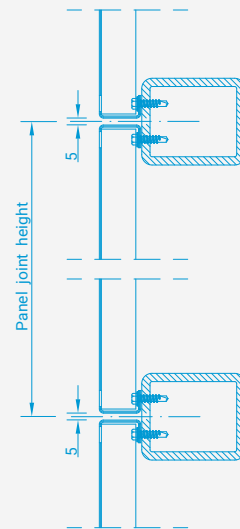

1. Perforated panel
2. Access hole for fastener
3. Panel flange (unperforated)
4. Structure

Installation ideas

Perforated profiled screens

The most economical option
Quick and easy to fix
Standard width of profile - 1100mm.

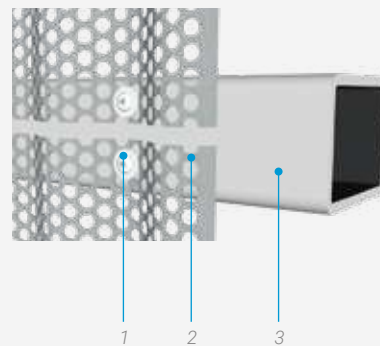
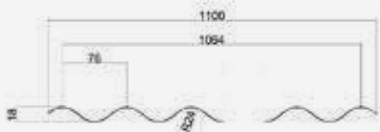
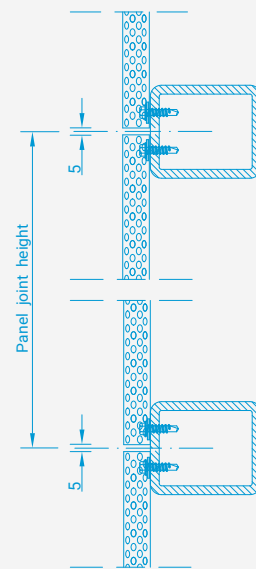
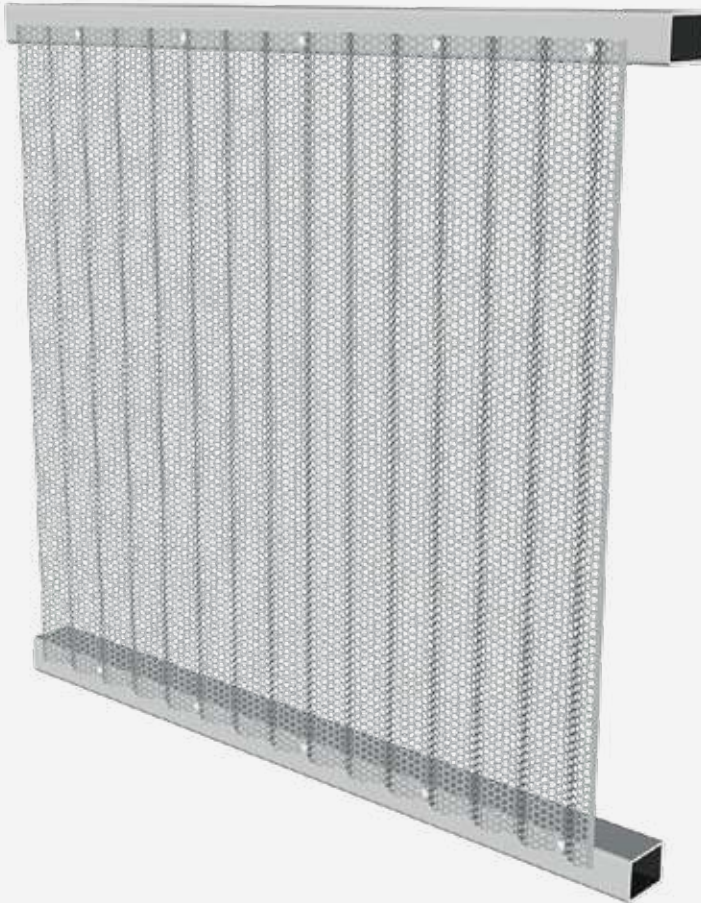

1. Profiled perforated screen
2. Fastener and washer
3. Structure

Installation ideas

Perforated folded screens

Folding of the screens can be easily customised, allowing for multiple effects. Developed width up to 1330mm with elZinc Wide. Minimal structural support required.

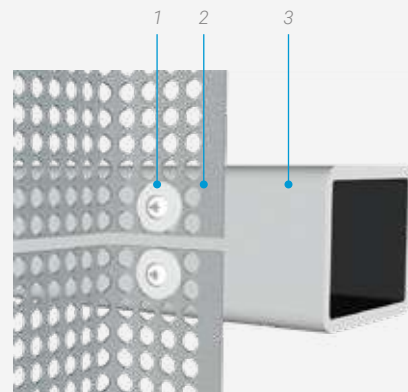
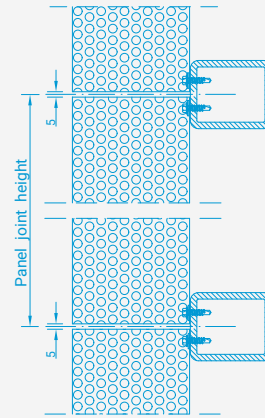
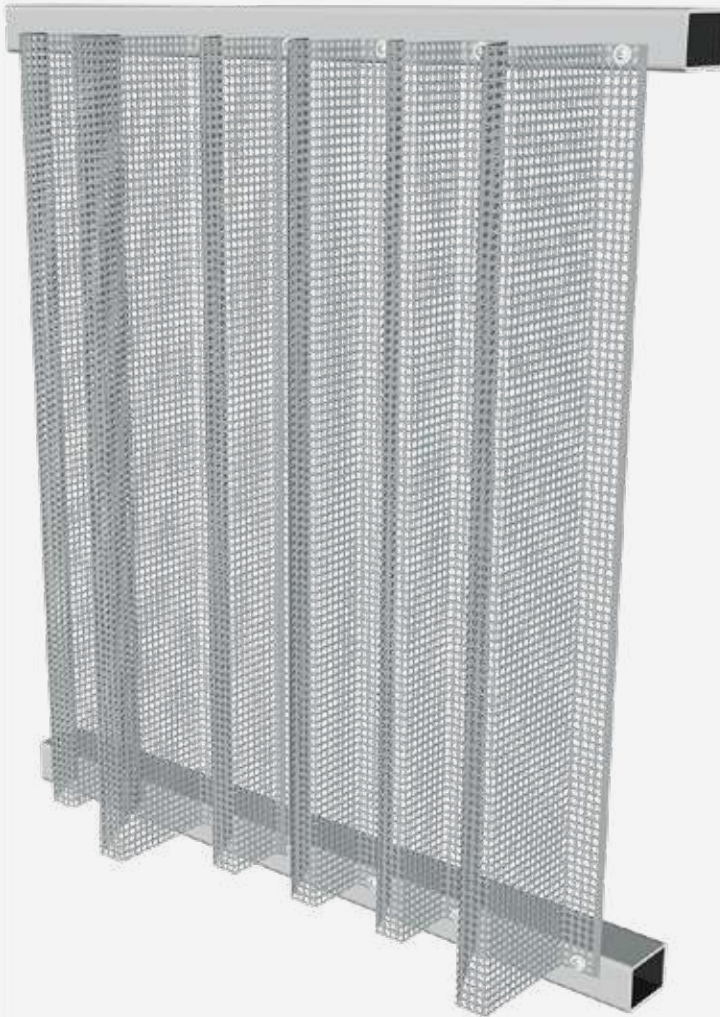

1. Folded perforated screen
2. Fastener and washer
3. Structure

Installation ideas

Perforated elZinc® drapes

Creates a light, metallic veil over the building, held in place by a system of tensioned stainless cables and guides. The veils can reach over multiple floors, whereas the cables are installed floor to floor. Some quilting is normally present in the zinc strips. Please contact elZinc® for more information on this system.

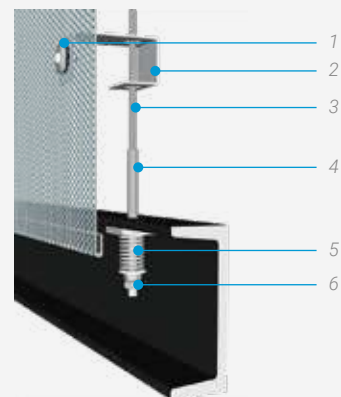

1. Stainless / EDPM washer and fastener
2. Cable guide
3. Stainless steel cable

4. Threaded terminal
5. Stainless steel tensioning spring
6. Stainless steel nuts

RW TP

R3 T4 | 51% free area

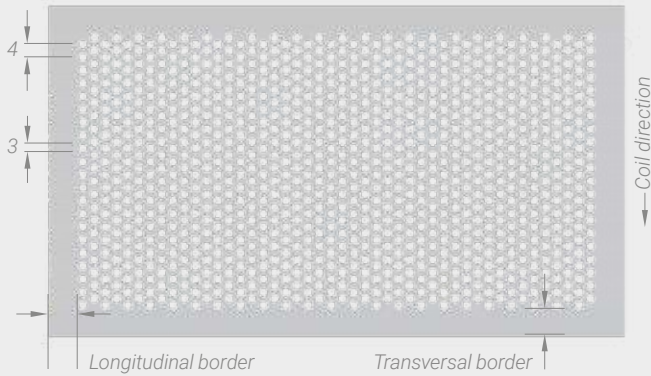

Standard round

RW TP

R4 T6 | 40% free area

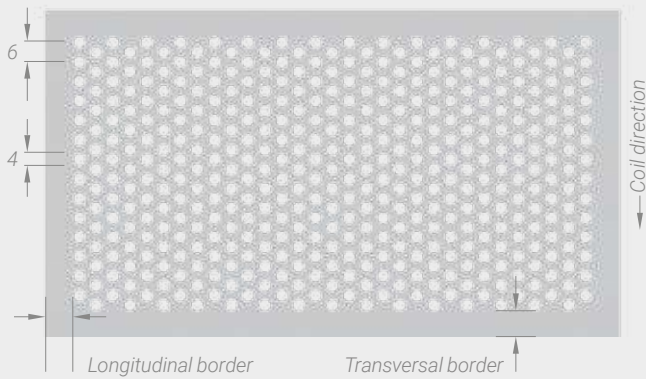

RW TP

R6 T9 | 40% free area

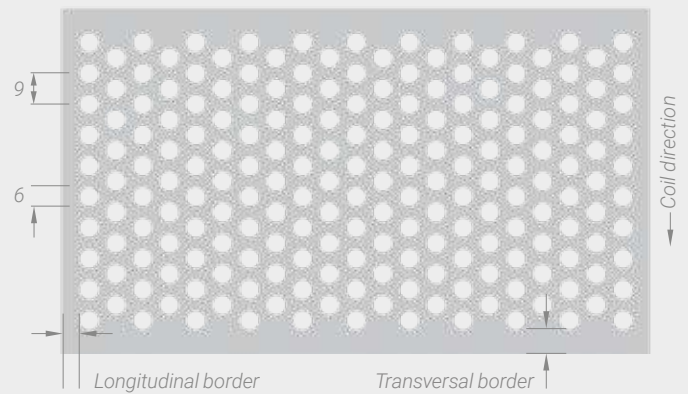

RW TP

R5 T7 | 46% free area

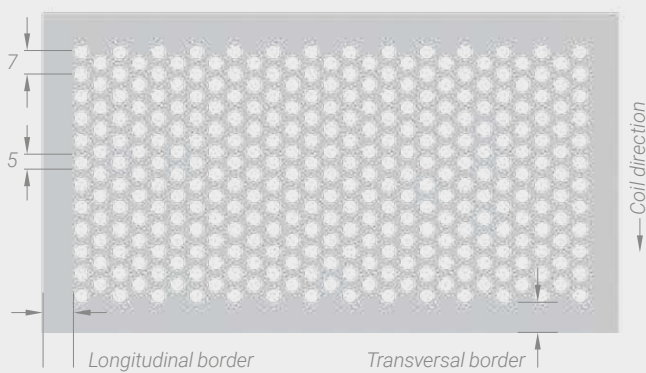

RW TP

R8 T11 | 48% free area

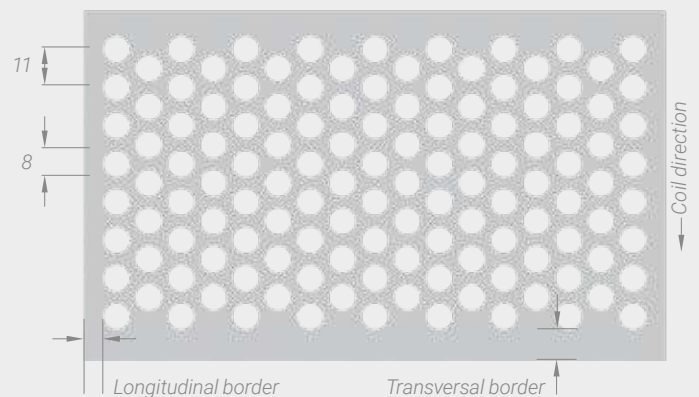

If you require custom perforations, please consult the elZinc manager in your area.

perforations.

RW TP

R10 T14 | 46% free area

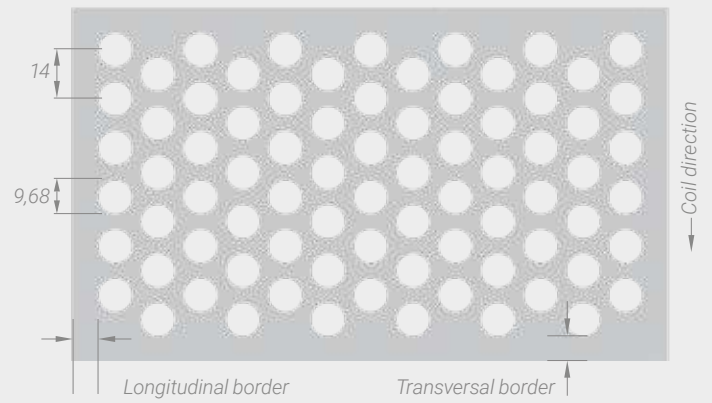

RW UP

R3 U8,8 | 9% free area

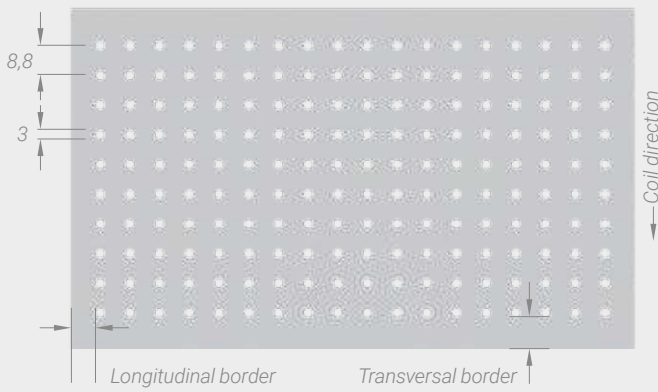

RW UP

R5 U13 | 12% free area

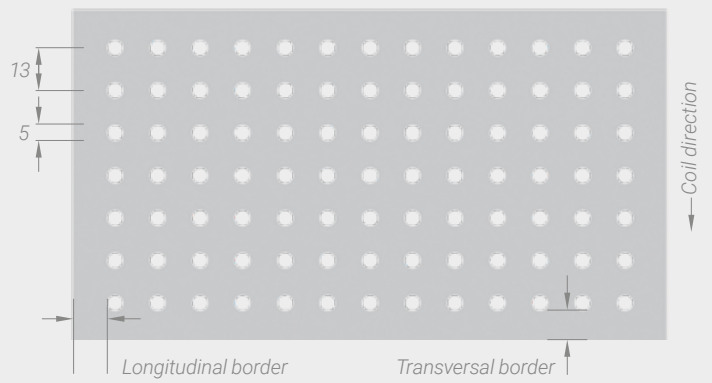

RW UP

R10 U24,2 | 13% free area

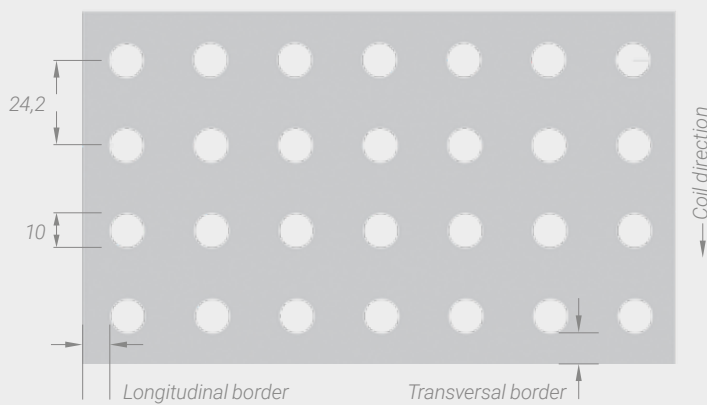

RW MP

R4 M6,22 | 32% free area



For square, rectangular and oval perforations, please check availability.



School of Design - Curtin University

Architect: John Wardle

elZinc Slate

Australia





Special perforated designs

With modern perforation technology, perforated elZinc® façades can be taken to the next level by introducing patterns over the panels. In this way, all the advantages of elZinc standard perforated panels are combined with designs that create textures and layers that really make the façade sing, and truly come to life.

elZinc® boasts three such designs, created together with the authors of the beautiful St-Louis nursery school in Paris featured above, Janez-Nguyen Architectes.

If however, you would like to explore other possibilities, elZinc's technical department is at your disposal to assist in the creation of a project specific design.

Our different models.

Design 'St-Louis'

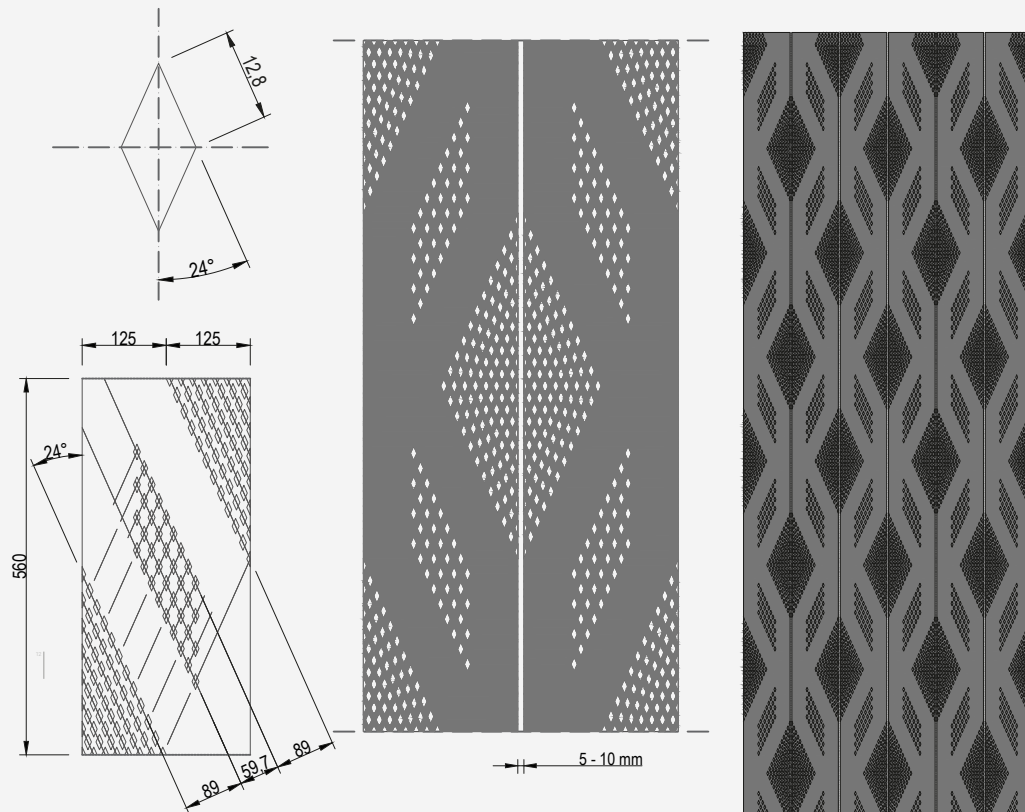

The panels were profiled into façade panels, whose slender shape lent itself perfectly to the narrow pattern of the perforation design.

Our different models.

Design 'St-Michel'

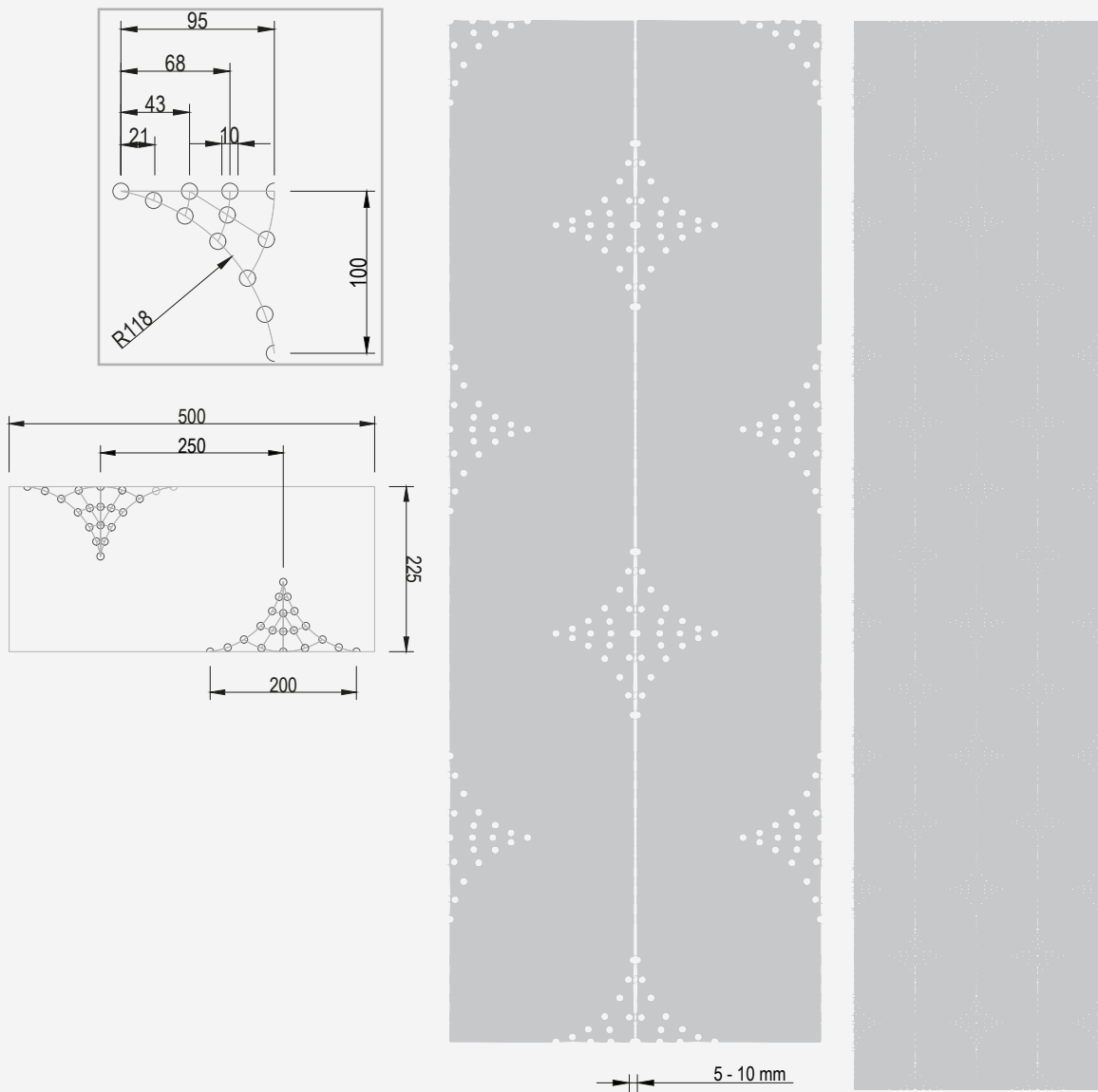

Our different models.

Design 'St-Germain' _____

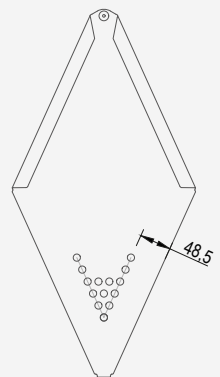
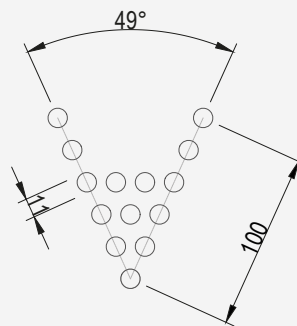
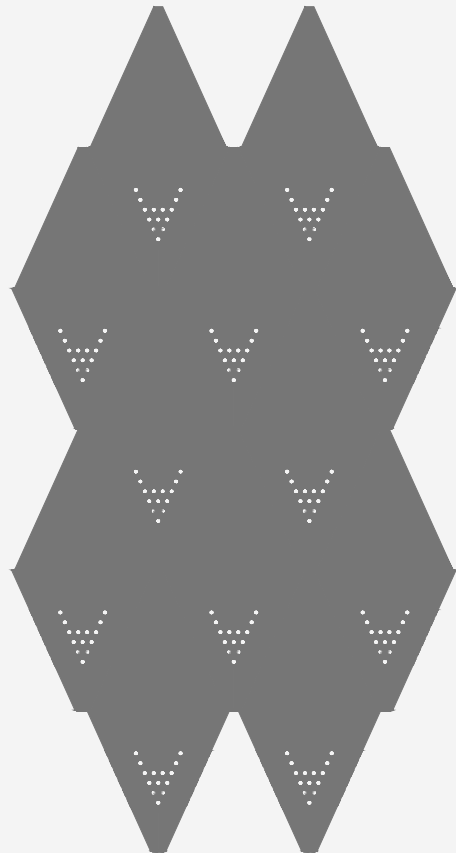
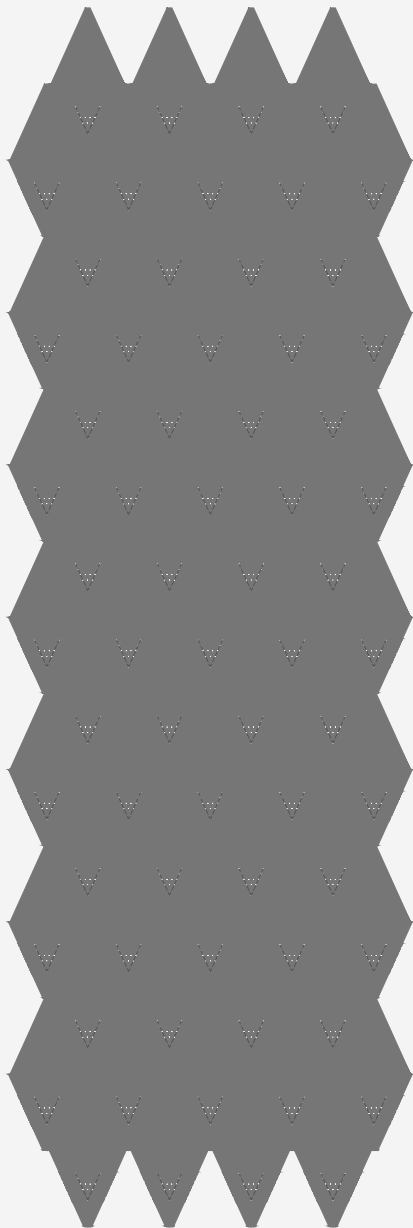

Delivery formats

The above designs are available in the following formats:

Design	Width (mm)	Length (mm)	Thickness (mm)
St-Louis	250 panel face width	Up to 4000mm	0,70mm
St-Michel	225 panel face width	Up to 4000mm	1,00mm
St-Germain	According to the tile		1,00mm

Other formats on request

Finishes

The full range of elZinc® finishes is available in all of the patterns.

Other information

The material is supplied with protective foil on one side.



elZinc® 3d panels

By combining perforation technology with pressing processes it is possible to create screens with a 3d structure. This interacts with ambient light creating shadows and reflections that introduce a whole new and striking visual layer to the finished façade.

The two designs use 5 different fixed sizes of perforations (round in one design, square in the other) and can be set in 4 different distributions to give varying densities of perforations. These varying densities can be mixed to give smooth transitions from areas of more to less perforation. If required, the perforation layout can be completely customised – consult elZinc for more details.

Our different models.

Rounded 3D design

Rounded 3D design plays with round perforations on a surface with 3d spherical indentations. The indentations alternate positive and negative across the panels in a uniform manner which is fixed at a different pitch to the hole centres. Thus the holes are never in the same position on the indentations, creating an interestingly changing interaction over the surface.

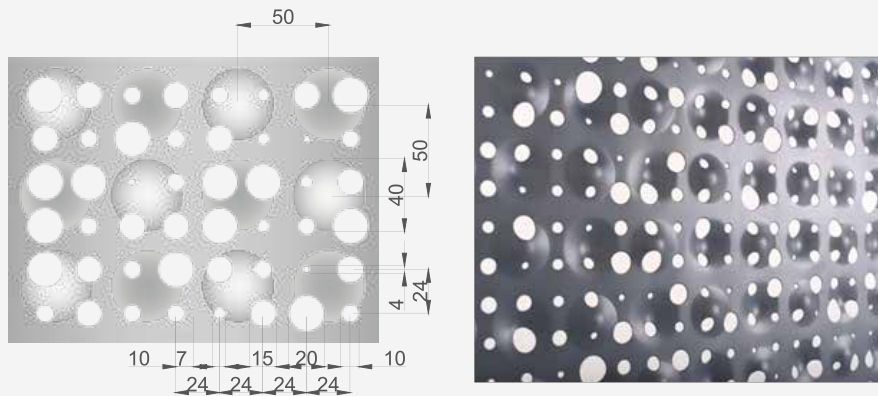

Square 3D design

Square 3D design plays with square perforations on a surface with square indentations. The indentations alternate positive and negative across the panel in a uniform manor which is fixed. The holes are 5 different fixed sizes and can be set in 4 different distributions to give varying densities of perforations, from a free area of 35% to 7%.

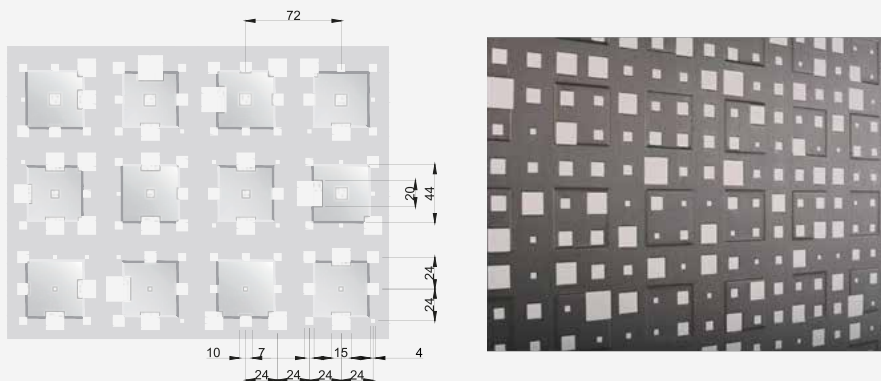

Installation ideas

Direct fixed perforated panels - hidden fixings

Can be installed horizontally or vertically. The perimeters are left free of perforation to create a frame around each panel.

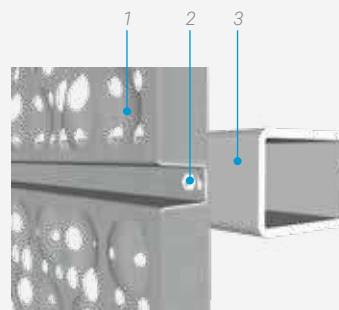
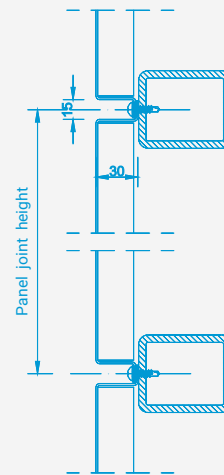
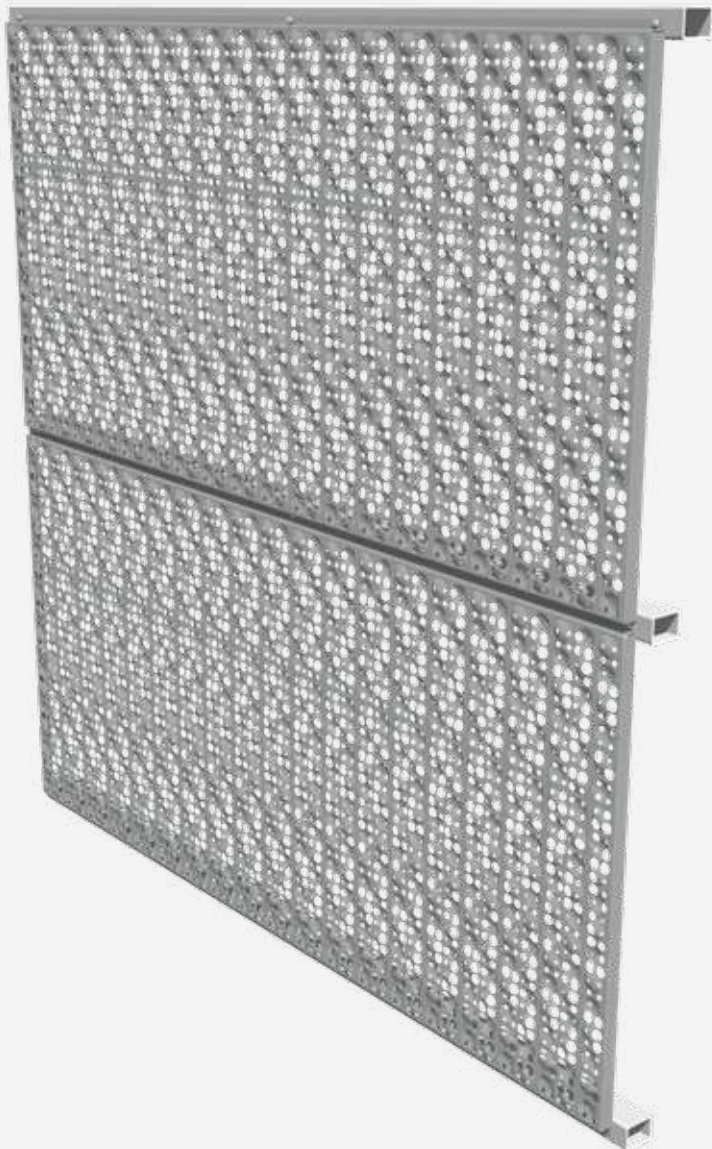

1. Folded 3d panel
2. Fastener
3. Structure

Installation ideas

Direct fixed perforated panels - hidden fixings

Can be installed horizontally or vertically.. The perimeters are left free of perforation to create a 'frame' around each panel.

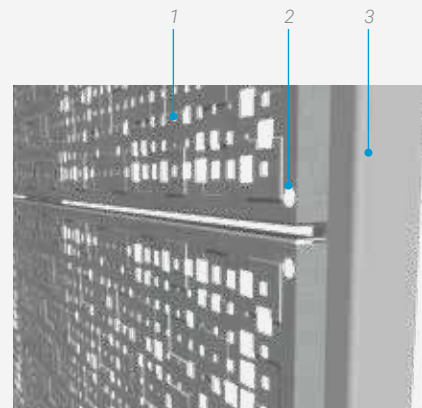
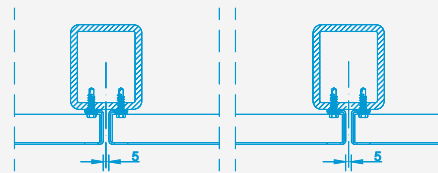

1. Folded 3d panel
2. Access hole for fastener
3. Structure

Delivery Formats

The above designs are available in the following formats:

Design	Width (mm)	Length (mm)	Thickness (mm)
Rounded 3D Design	1000	1000 and 2000	1 - 1,5 on request
Square 3D Design	1000	1000 and 2000	

Other formats on request

Finishes

The full range of elZinc® finishes is available in both designs.

Other information

The material is supplied with protective foil on one side.



eZinc Image

By using special software that takes images and converts them into patterns of perforations of different densities and sizes the architect can 'draw' over the entire facade, converting it into something completely unique.

Possibilities are pretty much endless. Just send us your design (in a jpg image or dwg file) and we will convert it into a striking image created in perforated eZinc®. Light finishes (eZinc Natural, eZinc Crystal, eZinc Slate) tend to be used to show up the contrast best between perforated and unperforated areas, and therefore make a clearer image.

Delivery formats

The above designs are available in the following formats:

Format	Width (mm)	Length (mm)	Thickness (mm)
Sheet	1000	Project defined, up to a maximum of 6000mm	According to the project
	1250		
	1330		

Other formats on request

Finishes

The full range of elZinc® finishes is available in both elZinc Expanded and expanded and rolled (flattened) elZinc.

Other information

The material is supplied with protective film.

Examples







elZinc[®] expanded

Expanded zinc is the ultimate in efficiency when it comes to enclosing spaces with an 'open' material. In contrast to perforated sheets, expanded zinc undergoes an industrial process that cuts and spreads out the sheet over its length, creating no waste in the process.

Moreover, in large patterns, the process results in significant rigidity across the width of the sheet, reducing the need for structural supports.

These panels are highly cost-effective yet retain all of the qualities that make zinc such an attractive cladding material - aesthetics, sustainability, practicality and durability.

elZinc expanded large format

Standard openings

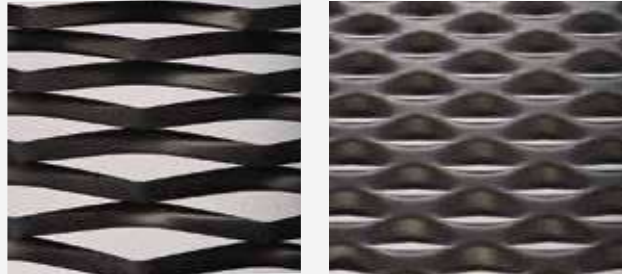
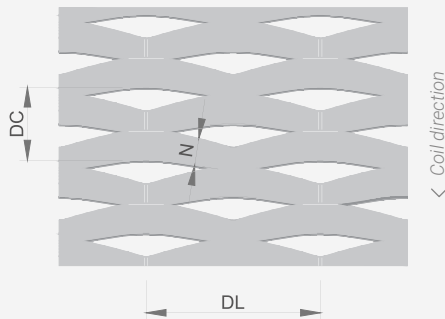

Format			Free area, %	Sheet weight, kgs/m2.
DL	DC	N		
90	38	16	15,8	4,55
110	52	24	7,7	4,98
122	50	20	40	4,32
170	80	30	25	4,05
190	60	20	33,3	3,60
265	90	30	33,3	3,60
290	88	24	45,5	2,95

Delivery formats

These products are available in the following standard formats:

Format	Length (mm)	Width (mm)	Thickness (mm)
Panel	1000	2000 and 3000	1,5
	1250		
	1330		

Other thicknesses, widths and lengths are available on request.

Finishes

The full range of elZinc® finishes is available in both elZinc Expanded and expanded and rolled (flattened) elZinc.

Other information

Due to the nature of the expansion process, the material cannot be supplied with protective film.

Expanded and rolled

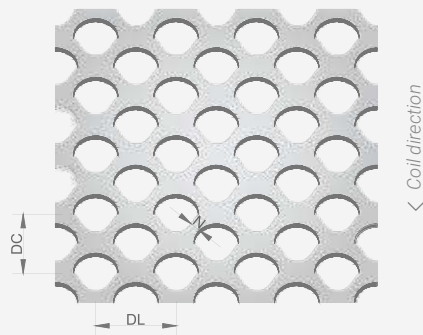

Dimensions			Free area, %	Sheet weight, kgs/m ²
DL	DC	N		
10	7,3	1,6	56	2,28
10	7,2	1,4	62	1,93

Delivery formats

Format	Width (mm)	Length (mm)	Thickness (mm)
Coil	1000	According to project requirements	0,7
	1250		
	1330		
Sheet	1000	2000 et 3000	
	1250		
	1330		

Other thicknesses, widths and lengths are available on request

Finishes

The full range of elZinc® finishes is available in expanded and rolled (flattened) elZinc®.

Other information

Due to the nature of the expansion process, the material cannot be supplied with protective film. Consult elZinc regarding edgewise bow tolerances on coil material.

Installation ideas

Direct fixed elZinc® expanded

These large format panels cannot be folded into cassettes, so are fixed directly to the structure with angled brackets

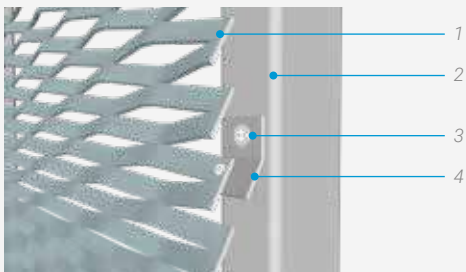
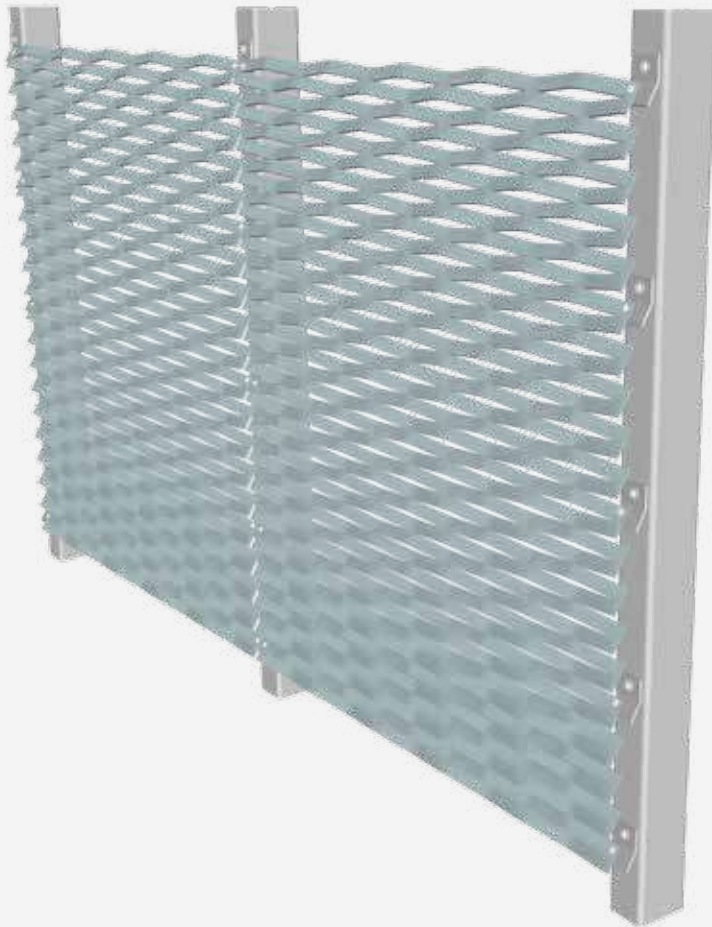

1. Expanded elZinc® panel
2. Structure
3. Fastener and washer
4. Bracket

Installation ideas

Direct fixed eZinc® expanded rolled panels - hidden fixings

Can be installed horizontally or vertically.

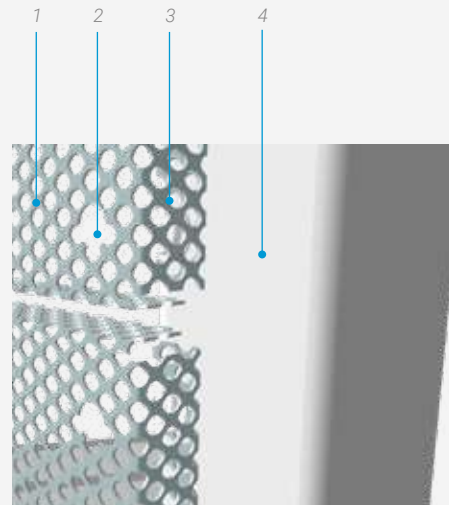
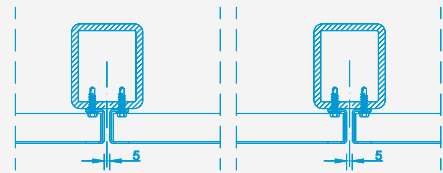

1. eZinc® expanded panel
2. Access hole for fastener
3. Panel flange (always perforated)
4. Structure

Installation ideas

Direct fixed expanded and rolled panels - visible fixings

Can be installed horizontally or vertically.

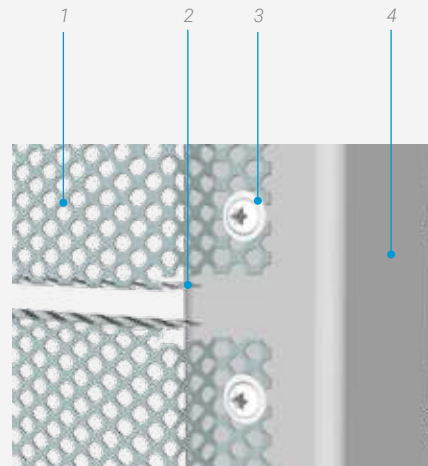
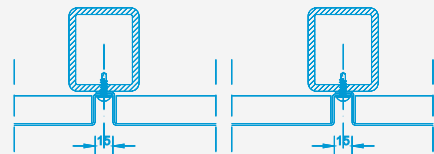

- 1. elZinc® expanded panel
- 2. Panel flange (always perforated)
- 3. Fastener
- 4. Structure

Installation ideas

eZinc expanded and rolled drapes

Creates a very light, metallic veil over the building. Supported by a system of tensioned stainless cables and guides
 Maximum length of veils in eZinc expanded – one floor (4mts). The cables usually go floor to floor
 Some quilting is normally present in the zinc veils.

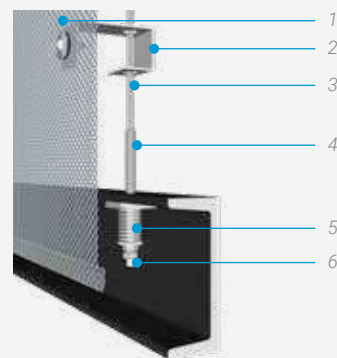
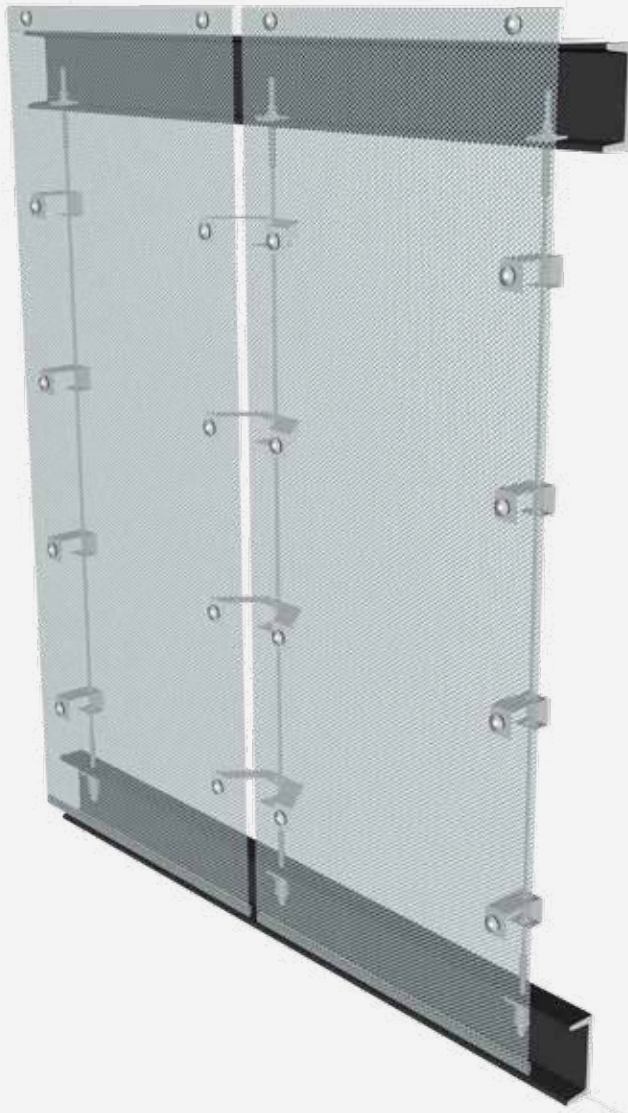

- | | |
|---|--------------------------------------|
| 1. Stainless / EDPM washer and fastener | 4. Threaded terminal |
| 2. Cable guide | 5. Stainless steel tensioning spring |
| 3. Stainless steel cable | 6. Stainless steel nuts |

DL90

15,8% free area

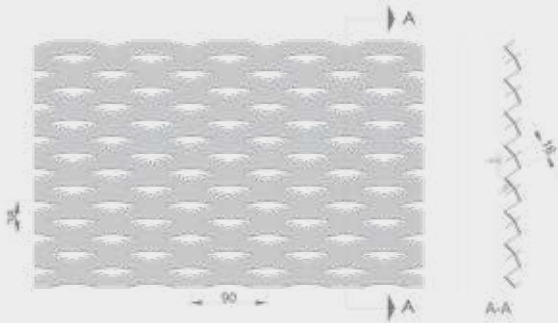

Expanded elZinc®

DL110

7,7% free area

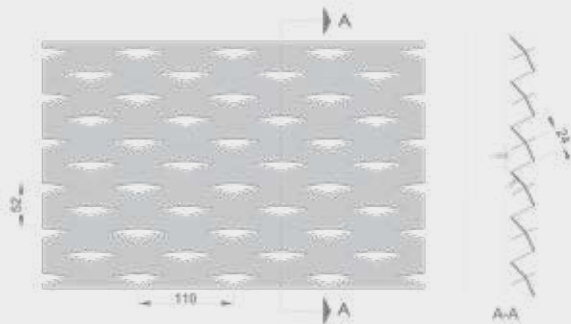

DL122

40% free area

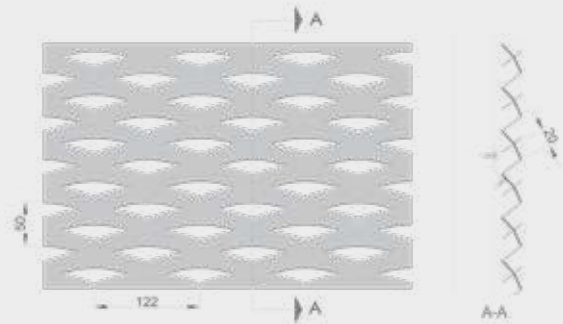

DL170

25% free area

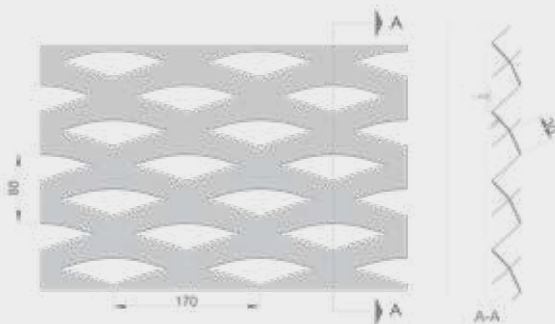

DL190

33,3% free area

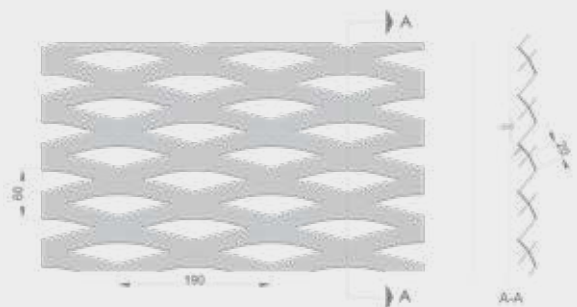

Expanded & rolled

DL290

45,5% free area

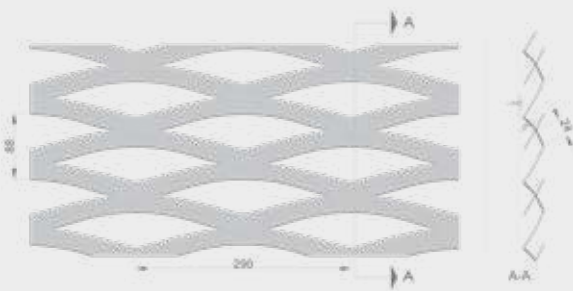

DL10

DC 7,2 N1,4 | 62% free area

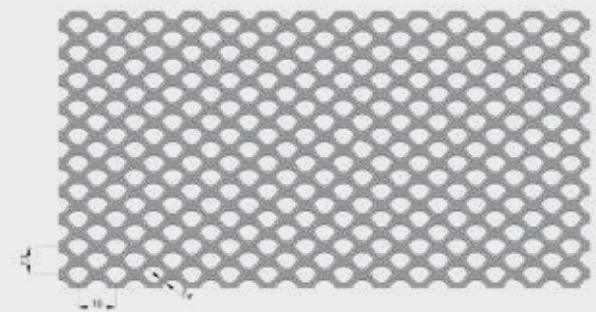

DL265

33,3% free area

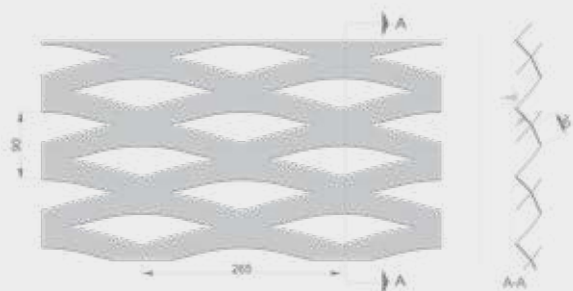

DL10

DC 7,3 N1,6 | 56% free area

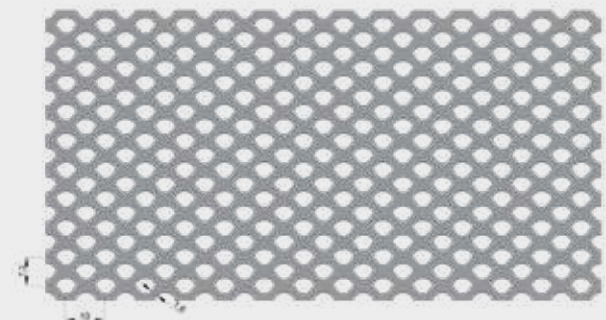



USINE ET SIÈGE SOCIAL

ASTURIANA DE LAMINADOS, S.A.
Pol. Ind. de Villallana, Parcela 1
33695 Pola de Lena – España

T (0034) 98 567 60 00 / 98 410 60 00
F (0034) 98 549 32 02 / 98 569 20 00
elzinc@aslazinc.com

www.elzinc.es

June- 2022