



The material
General Considerations

www.elzinc.es

elZinc

Designing with elZinc®



INDEX



01. Introduction.....	007
02. Environment.....	011
03. elZinc, constant innovation.....	017
04. Product data.....	021
05. elZinc finishes and their application.....	029
06. Weathering of elZinc products.....	043
07. Storage, transport and handling.....	051
08. Working and processing the material.....	059
09. Cleaning and maintenance.....	063
10. Compatibility.....	071
11. Zinc in costal environments.....	081
12. Zinc in hot and cold climates.....	087
13. Oil canning and tool marks.....	097
14. elZinc and fire safety.....	103
15. Lightning protection.....	109
16. Good practice on the building site.....	113
17. Project documentation.....	121
18. Presenting the most usual systems.....	127
19. Disclaimer.....	139
20. Useful Information.....	141
21. Glossary.....	145

This guide has been designed to help our customers, consultants and installers to handle and use the zinc-titanium elZinc correctly.

All the recommendations and advice you will find in this document will help you to better understand this extraordinary material and to make the most of its many aesthetic and functional benefits.





01

THE HISTORY OF ZINC

The history of zinc as a roofing material

It all starts in the middle of the 19th century when the city of Paris (France) experiences a significant demographic growth that made a total transformation of the city necessary.

In order to modernise the city and meet the needs of its growing population, Baron Haussmann - during the reign of Napoleon III - was appointed to oversee the regeneration work. The city changed radically, and numerous Haussmann-style buildings were built all over the city.

Haussmann chose zinc for the "dits à la Mansart" roofing: a cheap, easy-to-handle, lightweight material that was also a must for the avant-garde architecture he was pursuing. The light weight of this new material made it possible to take advantage of the top floors of Parisian buildings, where most of the servants in bourgeois residences were initially housed. For its installation, the batten roll technique was mainly used, which offered great flexibility and a unique aesthetic at the time.

The end result was that the Parisian roofs were not only beautiful and distinctive, but also innovative and allowed the creation of more living space.





02

ENVIRONMENT



Sustainable building is a concept that nowadays forms an integral part of architecture. It is no longer just an advantage, but rather an imperative as it is fundamental for both present and future generations.

Designing buildings to minimise their environmental impact is not only good for the environment, but also good for the people who work and live in them. Therefore, at elZinc® we develop high quality, aesthetically pleasing products that fulfil the requirements of Sustainable Building.

Zinc is everywhere and so much the better

Zinc : an indispensable element for life

Humans, animals, plants and even the smallest micro-organisms need zinc to function. There is no life without zinc. Indeed, zinc is one of the most important essential trace metals in human nutrition and lifestyle, and it is involved in various physiological processes like cell regeneration, growth activation, the development of vital organs; it is also present in many disease preventing medicines. The adult body contains about two to three grams of zinc.

Zinc a natural element

Zinc is an abundant mineral in nature, being found in water, air, soil and rocks. It is a natural component in the Earth's crust, and therefore an integral part of our environment. It has an average natural concentration of 70mg/kg.

Zinc as building material

elZinc®: a long-lasting building material

1- Resistant to weathering and corrosion

Zinc is a 'living' material, it protects itself by naturally developing a patina during the early stages of its life that guards against corrosion and gives it self-healing properties making it extremely durable. Its life span can exceed 100 years (depending on the surrounding atmosphere), indeed in wall cladding applications some experts estimate an expected life span of some 200 years. In order to guarantee the longevity of this versatile metal, correct execution of the zinc cladding is a must.

2- A low maintenance material

elZinc® roofing and cladding products are low-maintenance materials. They generally do not require any particular attention from the building owner and will give a long and cost-effective service life looking good and protecting the building from the weather for many decades.

The combination of just a few of the advantages of zinc - its long life service, lack of special maintenance and its weight (between 7 and 10Kg/m² which can help reduce the costs of building structures) - makes zinc a sound economical choice.

elZinc®: sustainable material

1- elZinc production and its environmental impact

Asturiana de Laminados, S.A., manufacturer of elZinc®, has implemented a comprehensive performance programme for the optimization of consumption and the reduction of waste.

The use of elZinc's cutting edge manufacturing technology gives the most efficient use of raw materials and reduces energy consumption even further.

Additionally, the production process is less energy intensive than other metals used in construction. Indeed, it is significantly less than in aluminium or copper production:

Metal	Characteristics
Aluminum 255 MJ/kg	482 MJ/m ² (0.7 mm thick aluminum)
Copper 70 MJ/kg	375 MJ/m ² (0.6 mm thick copper)
Zinc 51 MJ/kg	238 MJ/m ² (0.65 mm thick zinc)

Source: 'Sustainable Construction: Green Building Design and Delivery'.

When used as the building envelope, it contributes to preserving natural resources through efficient use of energy, reducing greenhouse gases and minimizing the use of existing zinc ore reserves.

2- Solar Reflectance Index

Solar reflectivity or reflectance is the ability of a material to reflect solar energy from its surface back into the atmosphere. The SRI value is a number from 0 to 1.0. A value of 0 indicates that the material absorbs all solar energy and a value of 1.0 indicates total reflectance.

Product	Solar reflectance	Thermal emittance	Solar Reflectance Index			Standard
			Convection coefficient (W/nTK)			
			Low 5	Medium 12	High 30	
elZinc Natural	0,61	0,044	-6	36	56	ASTM E1980
elZinc Slate	0,26	0,57	-2	9	18	ASTM E1980
elZinc Crystal	0,4	0,443	7,2	23	34,2	ASTM E1980
elZinc Oliva	Pending	Pending	Pending	Pending	Pending	
elZinc Lava	Pending	Pending	Pending	Pending	Pending	
elZinc Graphite	0,065	0,755	-11,9	-6,5	-1,9	ASTM E1980
elZinc Rainbow Red	0,194	0,868	15,6	16,9	18,1	ASTM E1980
elZinc Rainbow Brown	Pending	Pending	Pending	Pending	Pending	
elZinc Rainbow Gold	0,429	0,834	44,8	46,5	47,9	ASTM E1980
elZinc Rainbow Blue	0,203	0,867	16,7	18,1	19,3	ASTM E1980
elZinc Rainbow Green	0,211	0,796	12	15,3	18,2	ASTM E1980
elZinc Rainbow Black	Pending	Pending	Pending	Pending	Pending	

elZinc®: recyclable material

Zinc is 100% recyclable and can be reused a practically unlimited number of times, without the loss of any of its chemical or mechanical properties, or any loss in quality.

Note: All of the zinc by-products that are generated during the elZinc® production processes are recycled and reused, either in its own production processes or externally such as in the use of zinc oxide as a catalyst in the vulcanization of rubber.

elZinc, the certified environmental efficiency of our rolled products.

Our ecological footprint : EPDs elZinc Natural and elZinc Alkimi®

elZinc® has obtained Environmental Product Declarations «EPDs» for elZinc Alkimi® within the GlobalEPD Programme of AENOR (independent third-party ensuring data quality and reliability) and offer them to its customers.

These documents consist of life-cycle assessments carried out according to ISO14040/44 and EN15804 on the manufacture of the products and have a cradle to grave scope. They describe in detail the environmental footprint of our products.

elZinc products : Many advantages to get Leed certification

Well aware since our beginnings of the need to protect the environment, at elZinc all the necessary information regarding zinc's advantages in Green Building.

Thanks to its numerous advantages such as its complete recyclability or its longevity, titanium-zinc elZinc® can have an impact in up to 3 families of LEED
Please do not hesitate to contact us or read elZinc® LEED® certifications on our website.

ISO 14001

The ISO 14001 certification guarantees that elZinc manages its processes within a production model oriented towards total compatibility with the environment. Thanks to our continuous improvement system, we develop technical solutions that lead our transformation processes to excellence in terms of performance in resource usage.

ISO 50001

Obtaining the ISO 50001 Energy Efficiency certification means that we have implemented an energy management system. This sets the foundation for enabling us to achieve various goals in the future, including using energy more efficiently for example by implementing improvements to our facilities, conserving natural resources and addressing climate change by reducing our carbon footprint.



elZinc
Equipment

A vertical strip on the left side of the page shows industrial machinery. The top part features a white metal beam and a blue component. Below that is a yellow tray or container. The bottom part shows a large, dark, cylindrical object, possibly a roller or part of a conveyor system, with a bright light reflecting off its surface.

03

**elZinc,
CONSTANT
INNOVATION**

The key to success is to be in a state of constant innovation.

Established in 2006, Asturiana de Laminados, SA - under the brand name elZinc[®] - has become one of the 3 largest producers of rolled zinc with a presence in more than 50 countries.

A global benchmark company and technological leaders, we have committed to innovation and excellence from the very beginning.

Investment in technology makes us leaders in R+D, helping us to achieve the highest quality, most innovative solutions along with the constant improvement of our products. elZinc's innovative production technologies make completely new zinc applications. With five pre-weathered finishes, 6 finishes of coloured zinc (applicable on both faces of the coils on request), in thicknesses up to 2.5mm and widths up to 1340mm, elZinc has changed the standards of using zinc, opening up possibilities which, until now, were not viable in zinc.

For us, a good product is about more than just quality and a range of choices. It also consists of offering tools that facilitate the day-to-day life of our users and a personalised service that helps you achieve your goals.

We design high quality, attractive and durable products that contribute to the construction of beautiful and sustainable buildings.



ISO 9001

From its origins, Asturiana de Laminados, SA – elZinc® – has submitted itself to an ongoing process of improvement that has been accredited and endorsed by the internationally recognized standard for quality management UNE-EN ISO 9001.

elZinc®'s main concern and objective is to give our clients total satisfaction right from the time we first make contact.



KOMO CERTIFICATE

elZinc® has been awarded the prestigious Dutch KOMO certificate for its rolled products elZinc® Natural, elZinc Slate®, elZinc Rainbow® and elZinc Graphite®. This certificate, which follows a strict validation process, certifies that all elZinc® processes and products comply with the company's strict control measures to ensure the highest quality.



CE Marking

elZinc adopted the European directive on Building Products.

In respect and support of this measure, elZinc provides all its clients with the declarations of performance according to EN14782 and EN14783 standards which are used for CE marking

elZinc warranty

Our commitment to the customer is paramount. We work together in the development and improvement of our products based on their specific needs, guaranteeing they consistently receive a high quality, durable architectural zinc. One of the main characteristics of titanium zinc is its high resistance to corrosion. Produced using cutting edge technologies and according to a rigorous quality protocol, elZinc® is of exceptional quality. This is why we are able to guarantee all our elZinc Alkimi® finishes for life and offer you a guarantee that is UNIQUE in the sector and reflects the absolute confidence we have in our products.



ISO 45001

The company reinforces safety prevention as a strategic axis and perfects its occupational risk control processes by obtaining the ISO 45001:2018 Occupational Health and Safety Management System certification. People are our company's most important asset. Consequently, protecting the physical integrity and health of workers is a priority for elZinc.

Find more about elZinc Lifetime Warranty at: www.elzinc.es/en/the-company/rdi/elzinc-a-reliable-brand/

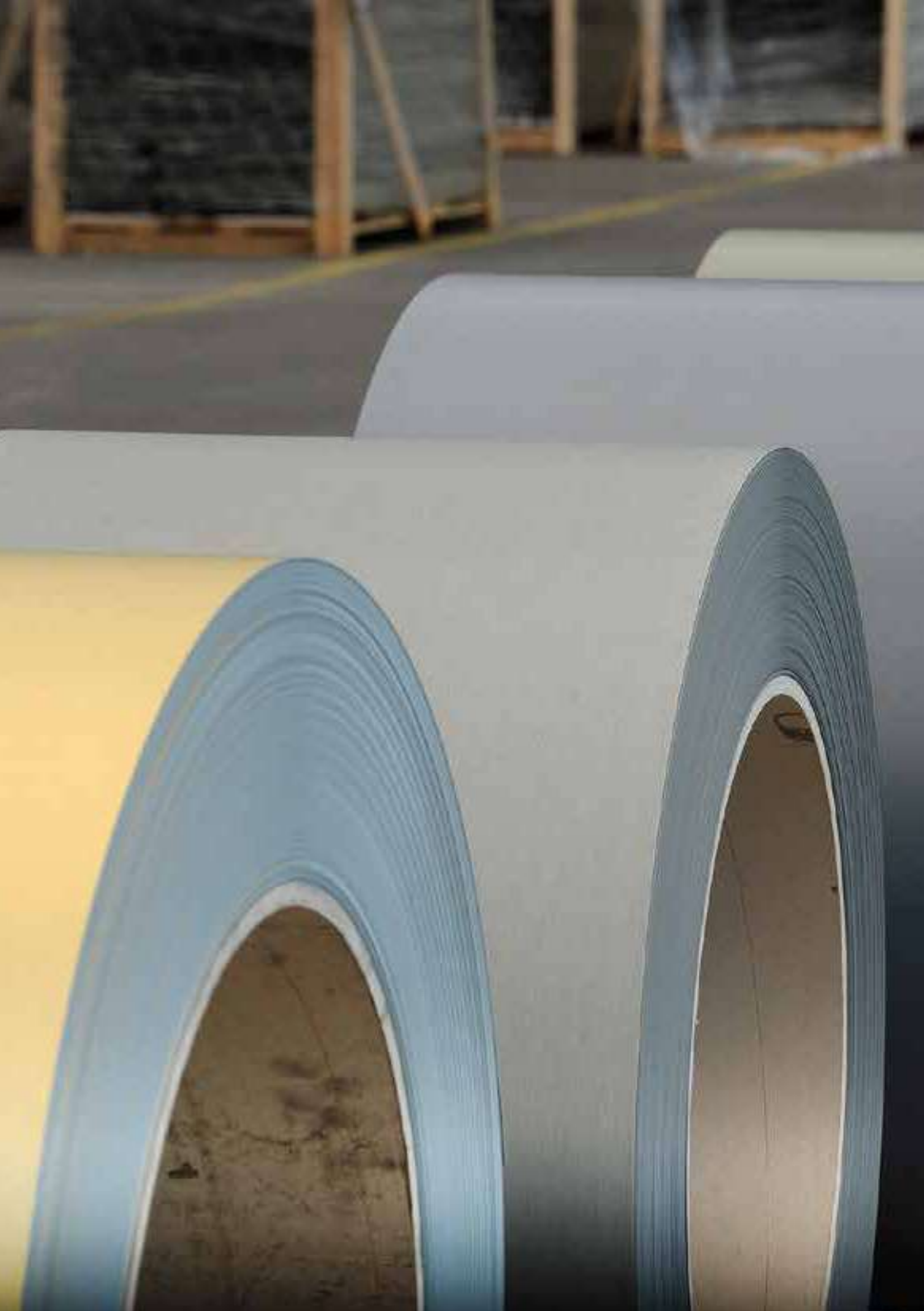



04

**PRODUCT
DATA**

Chemical composition, dimensional tolerances and mechanical properties.

All elZinc® sheet and coil for roofing and cladding is manufactured according to EN988:1996 and ASTM-B69. However, elZinc® betters the requirements and tolerances of these standards in a number of areas, producing titanium-zinc which are characterised by having the following outstanding properties:

- very good workability irrespective of the direction of rolling
- high creep strength (creep strain limit)
- low cold brittleness
- high recrystallisation threshold, i.e. no grain growth until 300°C; this is crucial for soldering

Characteristics	Unit	Value
Density	kg/dm ³	7,2
Coefficient of linear expansion, parallel to the direction of rolling	m/(m K)	22 x 10 ⁻⁶
Melting point	°C	approx. 420
Recrystallisation temperature	°C	min. 300
Thermal conductivity	W/(m K)	110
Electrical conductivity	mS/m	17

General properties - those not contemplated in the European EN or American ASTM Standards.

Properties contemplated in EN988 and ASTM B-69

Parameter	Criteria elZinc	Criteria EN988	Criteria ASTM B-69
Chemical composition			
Zinc	Zn 99,995 (Z1 according to EN 1179)	Zn 99,995 (Z1 according to EN 1179)	-
Pb, Fe, Cd, Sn, Mn & Mg	-	-	Max. 0,005%
Copper	0,08-0,20%	0,08-1,00%	0,08-0,20%
Titanium	0,07-0,12%	0,06-0,20%	0,07-0,12%
Aluminium	≤ 0,015%	≤ 0,015%	0,001-0,015%
Dimension / Tolerances for standard products			
Thickness of sheets/coils	± 0,01 mm	± 0,03 mm	±0,0254mm*/±0,0508mm**
Width of sheets/coils	+ 1/-0 mm	+ 2/-0 mm	± 1,575 mm
Length	+2/-0 mm	+10/-0 mm	± 5 mm
Edgewise bow	≤ 1,0 mm/m	≤ 1,5 mm/m	25,4 mm/3048 mm (arc radius 45,7m)
Flatness	≤ 2 mm	≤ 2 mm	-
Mechanical and technological properties in the direction of rolling			
Yield strength elasticity 0,2% (Rp 0,2)	> 110 N/mm ²	> 100 N/mm ²	-
Tensile strength (Rm)	> 150 N/mm ²	> 150 N/mm ²	96 - 262 N/mm ²
Breaking elongation (A50)	≥ 40%	≥ 35%	10 - 70%
Vickers hardness (HV3)	≥ 45	-	-
HR 15T hardness	-	-	54 - 74
Bending test	No cracks at the edge of fold	No cracks at the edge of fold	-
Bending back after folding test	No cracks	-	-
Erichsen test	Min. 7,5mm	-	-
Deformation after yield strength test (Rp0, 1)	≤ 0,1%	≤ 0,1%	-
Young's modulus			

* for thicknesses between 0,254 and 0,762mm

** for thicknesses between 0,762 and 1,524mm

As can be seen in the above table, titanium and copper are the significant alloying elements. The function of these alloying elements is to:

- Give better mechanical properties perfecting the material for use as a cladding material.
- Decrease creep (intrinsic to pure zinc).

Additional properties. - SRI Values

Product	Solar reflectance	Thermal emittance	Solar Reflectance Index			Standard
			Convection coefficient (W/nTK)			
			Low 5	Medium 12	High 30	
elZinc Natural	0,61	0,044	-6	36	56	ASTM E1980
elZinc Slate	0,26	0,57	-2	9	18	ASTM E1980
elZinc Crystal	0,4	0,443	7,2	23	34,2	ASTM E1980
elZinc Oliva	Pending	Pending	Pending	Pending	Pending	
elZinc Lava	0,106	0,711	-10,7	-3,8	1,9	ASTM E1980
elZinc Graphite	0,065	0,755	-10,7	-6,5	-1,9	ASTM E1980
elZinc Rainbow Red	0,194	0,868	15,6	16,9	18,1	ASTM E1980
elZinc Rainbow Brown	Pending	Pending	Pending	Pending	Pending	
elZinc Rainbow Gold	0,429	0,834	44,8	46,5	47,9	ASTM E1980
elZinc Rainbow Blue	0,203	0,867	16,7	18,1	19,3	ASTM E1980
elZinc Rainbow Green	0,211	0,796	12	15,3	18,2	ASTM E1980
elZinc Rainbow Black	Pending	Pending	Pending	Pending	Pending	

Please read how using elZinc® Natural and elZinc Rainbow® Gold can help obtain **credits in LEED certification** by consulting our document 'elZinc® in LEED certification', available from our web page.

RAL Numbers

Below is a list of RAL colours to use as a reference when selecting other materials that are required to combine with an elZinc finish.

elZinc Finish		Best match RAL
elZinc Alkimi®	elZinc® Natural	Not applicable
	elZinc Slate®	7037
	elZinc Crystal®	7042
	elZinc Oliva®	7005
	elZinc Lava®	7022
	elZinc Graphite®	9011
elZinc Rainbow®	elZinc Rainbow® Red	8025
	elZinc Rainbow® Brown	8014
	elZinc Rainbow® Gold	1002 / 1024
	elZinc Rainbow® Blue	7031
	elZinc Rainbow® Green	7002 / 7033
	elZinc Rainbow® Black	7021

Notes:

- Please bear in mind that our finishes are very different from the solid RAL colours, so the list on the left is the best matching RAL reference we have found for each finish, and is therefore an approximation only.
- In addition, some slight difference in colour tone can exist between different production batches of the Rainbow range.

To touch up areas we recommend using a polyurethane spray paint made up to the RAL colours in the table. It may be necessary to re-apply over time, as the touch up spray does not have the same durability as the factory applied finishes

Plastic protective film

Most elZinc® products are supplied with a protective adhesive film, designed to give optimal protection to the zinc's surface during transport, handling, fabrication into trays or panels, installation and if required for a limited time after installation.

Caution, the film is slippery when wet, exercise due care when walking on damp roofs.



The rolling direction of the zinc is shown on the film, as well as other safety instructions. The table below indicates the products that are supplied with film by default, on request and products that are not supplied with film.

Product family	elZinc Finish			
	elZinc Natural	elZinc Alkimi	elZinc Rainbow	elZinc Advance
Standard width coil and sheet	On request	Yes	Yes	Yes
Non-standard coil and sheet	Consult elZinc®			
elZinc® tiles	On request	Yes	Yes	Yes
elZinc® gutters	On request	Yes	Yes	N/A
elZinc® downpipes	Without film	Yes	Yes	N/A
elZinc® preformed flashings	Without film	Yes	Yes	N/A
elZinc® composite material, standard widths	Yes	Yes	Yes	Yes
elZinc® honeycomb material, standard widths	Yes	Yes	Yes	Yes

Film positioning

The following diagrams show the standard film positioning on the material.



Coil width	Film width, C	Right hand edge, A	Left hand edge, B
250	180	35	35
333	243	45	45
400	330	35	35
500	430	35	35
600	530	35	35
650	580	35	35
670	600	35	35
800	730	35	35
1000	990	5	5
1100	1090	5	5
1220	1210	5	5
1250	1240	5	5
1340	1330	5	5

Above dimensions are in mm. They are not exact and may vary by a few mm. Additional film widths and edge margins are possible on consultation with elZinc®. The minimum edge margin is 5mm.

Film removal

Correct behaviour of the film on removal cannot be guaranteed beyond 8 months after dispatch from elZinc, and the film should be immediately removed after installation.

Over these limits the film can become brittle and be very time consuming (therefore costly) to remove. Adhesive residue can also remain on the surface of the zinc, which is difficult to remove.

Partial removal of film (which is necessary on transversal joints of flat lock shingles and standing seam trays, for example) is best done before the panels are installed and in such a way as to protect the visible face but enabling easy film removal after interlocking the joints. If partial film removal is left until installation, it can leave larger and non-uniform areas exposed to 'early' weathering. This will cause temporary differential patination effects between the protected and unprotected surfaces, especially on elZinc Natural in more aggressive environments, and to a lesser extent elZinc Alkimi®. On elZinc Rainbow® and elZinc Advance® finishes any differences due to dust and dirt can be wiped away.



Partial removal of protective film causing differential weathering on natural zinc. These differences will weather-out over time



Partial removal of protective film causing marking of Rainbow brown – this can be wiped away.

Whilst these differences will even-out over time, the following procedure is recommended for partial removal of film.

Peel back the film so that the line along which the cut is to be made is a few millimetres off the zinc. Taking care not to score the zinc surface (a sheet of scrap zinc can be placed in between), cut the film along the line. Alternatively, a piece of scrap zinc can be used to score the film (check first that the elZinc finish is not damaged by the scoring). The remaining film should be smoothed down again against the zinc, keeping the edge of the film tight against the zinc, and avoiding leaving pockets that can, at best, encourage water to be drawn in between the film and the zinc and at worst directly gather and retain water. Especially with elZinc® Natural, in areas with high atmospheric pollution or near the sea, trapped water can generate surface marks and even lead to surface corrosion, which if required to be cleaned, can be difficult.

Marking

All elZinc® sheets and coils are identified with a serial number to ensure traceability. This automatic marking on the inside surface of the metal guarantees product traceability and quality of the material. It consists of 5 segments:

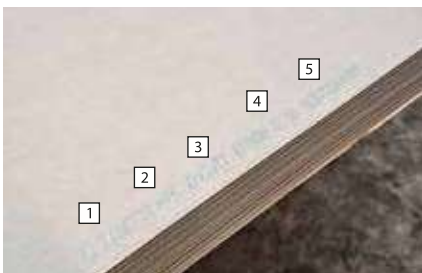

1. elZinc.
2. ZnCuTi alloy.
3. EN988 standard.
4. The one ren thickness.
5. Coil and casting identifying code.





05

**elZinc FINISHES
AND PRODUCTS**

As a manufacturer of rolled zinc, we have developed a wide range of zinc surface finishes for architectural metal cladding. Its versatility in terms of implementation systems and surface aspects allows it to be installed inside or outside, to cover the entire building or to be used as a decorative element.

Available manufacturing options:

Rolling Thicknesses: from 0,2mm to 2,5mm.

Rolling Widths: From 70mm to 1.340mm.

Coil weights: from 50kg to 10.000kg.

Our timeless and elegant aesthetics finishes



elZinc Alkimi® - Pure elegance

The appearance of the elZinc Alkimi® range is the result of a unique surface treatment carried out with elZinc technology and know-how.



elZinc® Natural

The original titanium zinc fresh from the rolling mill. elZinc® natural starts its life showing a metallic silver colour. The natural patina turns the finish to a pleasant matt grey colour.



elZinc Slate®

A pre-patinated matt grey zinc having a very similar appearance to naturally weathered zinc. It harmonizes perfectly with other building materials.



elZinc Lava®

A basalt grey pre-weathered zinc. Its colour sits perfectly amongst the other finishes in the elZinc range.



elZinc Graphite®

An architectural zinc pre-weathered to a very dark, almost black, shade of grey. Combined with other material such as wood or glass, it allows the creation of stylish facades.



elZinc Oliva®

A dark grey pre-weathered zinc with subtle greenish and bluish hues. Its tones guarantee a natural and balanced contrast with the surrounding environment.



elZinc Crystal®

The changing reflections of this pearl grey pre-patinated zinc play with light and give it a different look depending on its orientation.



elZinc Rainbow® - Zinc doesn't have to be grey

elZinc Rainbow® is available in a range of natural and warm graded colours in red, blue, green, black, gold and brown. The 35µm organic coating is a very attractive and durable finish that provides additional protection against corrosion.

elZinc has also developed a process which allows it to offer **custom colours**. Don't hesitate to ask about personalized finishes.



elZinc Rainbow® Red



elZinc Rainbow® Green



elZinc Rainbow® Brown



elZinc Rainbow® Gold



elZinc Rainbow® Ebony



elZinc Rainbow® Blue

Technical finishes

In order to reinforce the technical characteristics offered by our rolled zinc while preserving their aesthetics, we have developed technical solutions:

elZinc Advance®

The ideal solution for projects exposed to a corrosive environment and requiring additional protection.

Available in elZinc Slate®, elZinc Crystal®, elZinc Graphite®, elZinc Lava®, elZinc Oliva®.

elZinc Protect+

Allows the use of elZinc rolled zinc on substrates normally incompatible with zinc. Available in elZinc® Natural, elZinc Slate®, elZinc Crystal®, elZinc Graphite®, elZinc Lava®, elZinc Oliva® and elZinc Rainbow®.





Delivery programme

		elZinc Alkimi®: elZinc® Natural, elZinc Slate®, elZinc Graphite®, elZinc Crystal®, elZinc Oliva® & elZinc Lava®							
		1 coil per pallet		6 small coils per pallet		Sheet (1000kg* pallet)			
						2000x1000mm		3000x1000mm	
Thickness mm	Width mm	Aprox. Length m	Theoretical weight kg	Aprox. Length m	Theoretical weight kg	Weight'/ Sheet kg	Sheets/ Pallet	Weight'/ Sheet kg	Sheets/ Pallet
0,5	1000	278	1000	-	-	-	-	-	-
0,65	500	428	1000	31	73	-	-	-	-
0,65	650	329	1000	31	94	-	-	-	-
0,65	1000	214	1000	21	98	-	-	-	-
0,7	500	397	1000	40	100	-	-	-	-
0,7	600	331	1000	34	100	-	-	-	-
0,7	650	305	1000	31	101	-	-	-	-
0,7	670	305	1000	30	101	-	-	-	-
0,7	1000	198	1000	20	101	10,08	102	15,12	66
0,8	500	347	1000	34	101	-	-	-	-
0,8	600	289	1000	30	100	-	-	-	-
0,8	670	267	1000	30	100	-	-	-	-
0,8	1000	174	1000	17	98	11,52	89	17,28	58
1	500	277	1000	28	101	-	-	-	-
1	600	231	1000	23	99	-	-	-	-
1	670	214	1000	21	99	-	-	-	-
1	1000	138	1000	14	101	14,40	69	21,60	46
1,2	500	231	1000	-	-	-	-	-	-
1,2	600	193	1000	-	-	-	-	-	-
1,2	670	173	1000	-	-	-	-	-	-
1,2	1000	116	1000	-	-	17,28	58	25,90	39
1,5	500	185	1000	-	-	-	-	-	-
1,5	600	154	1000	-	-	-	-	-	-
1,5	670	138	1000	-	-	-	-	-	-
1,5	1000	93	1000	-	-	21,60	46	32,40	31
2	500	139	1000	-	-	-	-	-	-
2	600	116	1000	-	-	-	-	-	-
2	670	104	1000	-	-	-	-	-	-
2	1000	69	1000	-	-	28,80	35	43,2	23

*Theoretical weight. Coils inner diameter: Coil weight ≥250 kg - 508mm Other dimensions and thicknesses are available upon request. All products (except elZinc Natural) are supplied with a protective film by default, elZinc Natural with film on request.

Delivery programme

		eZinc Rainbow®							
		1 coil per pallet		6 small coils per pallet		2000x1000mm sheets			
						approx. 200kg*/pallet		approx. 500kg*/pallet	
Thickness mm	Width mm	Aprox. Length m	Theoretical weight kg	Aprox. Length m	Theoretical weight kg	Weight/ Sheet kg	Sheets/ Pallet	Weight/ Sheet kg	Sheets/ Pallet
0,5	1000	278	1000	-	-	-	-	-	-
0,7	500	397	1000	40	100	-	-	-	-
0,7	600	331	1000	34	100	-	-	-	-
0,7	650	305	1000	31	101	-	-	-	-
0,7	670	296	1000	31	104	-	-	-	-
0,7	1000	198	1000	20	101	10,08	20	10,08	50
0,8	500	347	1000	35	101	-	-	-	-
0,8	600	289	1000	30	103	-	-	-	-
0,8	650	267	1000	26	98	-	-	-	-
0,8	670	259	1000	26	100	-	-	-	-
0,8	1000	174	1000	17	98	11,52	17	11,52	43
1	500	277	1000	28	101	-	-	-	-
1	600	231	1000	23	99	-	-	-	-
1	650	214	1000	21	98	-	-	-	-
1	670	207	1000	21	101	-	-	-	-
1	1000	138	1000	14	101	14,40	14	14,40	35
1,2	500	231	1000	-	-	-	-	-	-
1,2	600	193	1000	-	-	-	-	-	-
1,2	650	178	1000	-	-	-	-	-	-
1,2	670	173	1000	-	-	-	-	-	-
1,2	1000	116	1000	-	-	17,30	14	14,40	29
1,5	500	185	1000	-	-	-	-	-	-
1,5	600	154	1000	-	-	-	-	-	-
1,5	650	142	1000	-	-	-	-	-	-
1,5	670	138	1000	-	-	-	-	-	-
1,5	1000	93	1000	-	-	21,60	9	21,60	23
2	500	139	1000	-	-	-	-	-	-
2	600	116	1000	-	-	-	-	-	-
2	650	107	1000	-	-	-	-	-	-
2	670	104	1000	-	-	-	-	-	-
2	1000	69	1000	-	-	28,80	7	28,80	17

*Theoretical weight. Coils inner diameter: Coil weight ≥250 kg ; 508mm Other dimensions and thicknesses are available upon request. All products (except eZinc Natural) are supplied with a protective film by default, eZinc Natural with film on request.

elZinc wide

All our finishes are also available in format unique on the market: up to a width of 1340 mm.

Main advantages

- Making internal gutters and other flashing wider than ever (>1000mm)
- Wider solutions which improve efficiency and reduce installation time for sinusoidal, trapezoidal and other systems.
- Material high performance thanks to the optimization of slitting.
- Wider composite and honeycomb panels according to market standards.

Standard sizes of sheets and coils

- Widths: up to 1340mm
- Thicknesses: from 0.2mm up to 3mm
- Sheets: up to 1340mm x 6000mm

		eZinc Wide							
		1 coil per pallet		6 small coils per pallet		Sheet (1000kg* pallet)			
						2000x1000mm		3000x1000mm	
Thickness mm	Width mm	Aprox. Length m	Theoretical weight kg	Aprox. Length m	Theoretical weight kg	Weight*/ Sheet kg	Sheets/ Pallet	Weight*/ Sheet kg	Sheets/ Pallet
0,5	1219	228	1000	-	-	7,2	139	10,8	93
0,5	1250	222	1000	-	-	7,2	139	10,8	93
0,5	1340	207	1000	-	-	7,2	139	10,8	93
0,65	1219	175	1000	-	-	9,3	107	14,0	71
0,65	1250	171	1000	-	-	9,3	107	14,0	71
0,65	1340	159	1000	-	-	9,3	107	14,0	71
0,7	1219	163	1000	-	-	10,1	99	15,1	66
0,7	1250	159	1000	-	-	10,1	99	15,1	66
0,7	1340	148	1000	-	-	10,1	99	15,1	66
0,8	1219	142	1000	-	-	11,5	87	17,3	58
0,8	1250	139	1000	-	-	11,5	87	17,3	58
0,8	1340	130	1000	-	-	11,5	87	17,3	58
1	1219	114	1000	-	-	14,4	70	21,6	46
1	1250	111	1000	-	-	14,4	70	21,6	46
1	1340	104	1000	-	-	14,4	70	21,6	46
1,2	1219	95	1000	-	-	17,3	58	25,9	39
1,2	1250	93	1000	-	-	17,3	58	25,9	39
1,2	1340	86	1000	-	-	17,3	58	25,9	39
1,5	1219	76	1000	-	-	21,6	46	32,4	31
1,5	1250	74	1000	-	-	21,6	46	32,4	31
1,5	1340	69	1000	-	-	21,6	46	32,4	31
2	1219	57	1000	-	-	28,8	35	43,1	23
2	1250	56	1000	-	-	28,8	35	43,1	23
2	1340	52	1000	-	-	28,8	35	43,1	23
2,5	1219	46	1000	-	-	Consult availability and possible sizes			
2,5	1250	44	1000	-	-	Consult availability and possible sizes			
2,5	1340	41	1000	-	-	Consult availability and possible sizes			
3	1219	38	1000	-	-	Consult availability and possible sizes			
3	1250	37	1000	-	-	Consult availability and possible sizes			
3	1340	35	1000	-	-	Consult availability and possible sizes			

elZinc tiles

Whether for new-build or refurbishment projects, prefabricated elZinc® tiles are a great solution for wall cladding and for weathering roofs pitched over either 25° or 45° (depending on the type of tile used).

Our five types of shingles, made of elZinc® zinc-titanium (EN988 standard), lend themselves to all architectural styles, harmonising perfectly with the surrounding materials.

In addition to their ecological and aesthetic qualities, elZinc® tiles are:

- Easy to install.
- Suitable for most projects.
- Highly corrosion resistant.
- Virtually maintenance free.

elZinc's® range of tiles are available in every elZinc® surface finish



Rainwater system

The complete range of rainwater drainage solutions is available in four different finishes (elZinc Natural, elZinc Slate®, elZinc Graphite® and elZinc Crystal®) and respond to a wide range of technical and aesthetic requirements.

The gutters and accessories in this range, in addition to the complementary profiles and roof flashings, are produced using elZinc® zinc titanium which is manufactured in accordance with the requirements of standard EN988.

These elements are suitable for all weather conditions and their high level of resistance to corrosion helps to ensure the longevity and integrity of the buildings that they are fitted on. The timeless quality of elZinc elements means that they look at home installed in any type of building.



elZinc honeycomb panel

The elZinc® honeycomb panel, manufactured in a continuous production process, is a new generation material, and represents the perfect integration of technology, safety, durability and natural beauty.

elZinc® A2 fire rated panels are formed by two elZinc® skins bonded to both faces of an aluminium honeycomb core, making an extremely light, yet exceedingly flat and ridged architectural cladding material.

The ample range of combinations and colours available enables the use of elZinc® to create innovative designs both in new-build and in refurbishment projects.

Very easy to install, it also allows:

- Cost and weight reduction
- Easy panel replacement (no need to touch surrounding panels)
- Vertical and horizontal installation orientation
- Free but controlled thermal expansion and contraction
- Fully adjustable fixing points in three directions
- Total security



elZinc composite panel

elZinc® composite material is a high-quality wall cladding material, providing long-term performance and flexibility of design for the most demanding of projects.

It consists of two elZinc® sheets continuously bonded to a ridged core made of either low-density polyethylene (PE) or of mineral filled Fire-Resistant resin (FR) to provide flatness and lightness. The FR core material is defined as providing very little contribution to a fire by Euroclass fire classification.

elZinc® composite panel will enhance your most creative project with its wide range of finishes (elZinc Alkimi® and elZinc Rainbow®).

Perforated range

elZinc Light is elZinc in sheet or coil format that has been perforated or expanded, and in some cases pressed into different 3d forms afterwards. These formats can be used to produce interesting solar screening solutions, decorative interior design options or discreetly in tradition roofing as the humble insect mesh.

Due to zinc's self-healing properties, the cut edges are left to patinate naturally in the weather to a warm, mat grey colour. Installation is simple and can be carried out by general cladding companies with no special knowledge of traditional zinc work techniques



Perforated

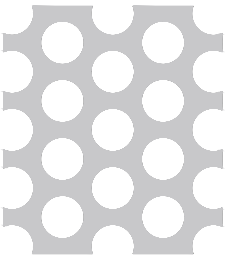

Expanded

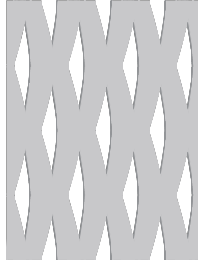

Special products

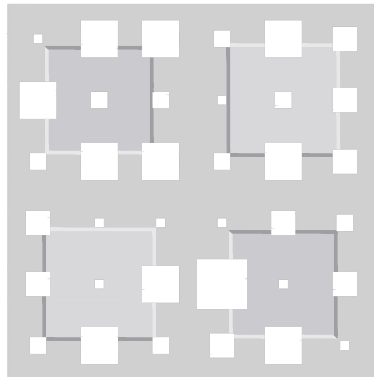
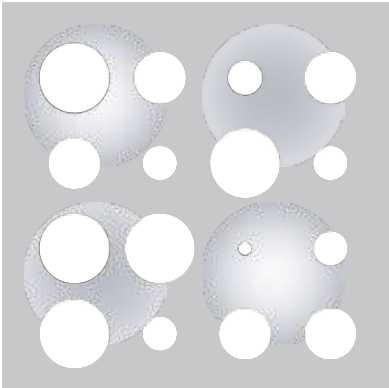







06

WEATHERING OF eZinc PRODUCTS

One of the most outstanding and persuasive features of elZinc® products is their weathering characteristics, both in our elZinc Alkimi® pre-weathered range and in our coloured Rainbow range. The innate properties of zinc ensure that the finishes in the elZinc Alkimi® range age gracefully, providing a canvas upon which the attractive natural patina effects of the weather on the building can be observed slowly over the years and decades. The subtle colours of the elZinc Rainbow® range on the other hand can be expected to remain virtually unchanged for a very long time due to the finish's excellent resistance to corrosion and UV radiation.

All elZinc® finishes are also **self-healing**. Any scratches that go through the finish to the bare zinc below trigger the natural patinating process of the exposed metal, protecting it and the surrounding area from corrosion. The patina that re-forms over the exposed zinc is the same colour as a naturally patinated zinc roof – mat grey and very similar to elZinc Slate®. This healing process takes the same time to complete as it takes a natural patina to form, and depends on local atmospheric conditions and the orientation and exposure of the metal.

Specific weathering by finish

elZinc Natural

elZinc® Natural is a naturally weathering cladding material which spontaneously develops a protective patina, giving it outstanding corrosion resistance and durability - even in harsh environments. This process, which takes on average between 3 to 5 years to complete, changes its colour from a bright shiny silvery metal to a mat grey colour. The resulting patina cannot peel, blister, flake or chalk.

The initial stages of the normal weathering process can produce a somewhat irregular appearance over the zinc cladding due to differential exposure to rain (caused for example by its orientation, or by chimneys or other buildings blocking localised rainfall). Natural zinc reacts with neutral water and also with acidic and alkaline liquids (under \approx pH 6 and over \approx 10 respectively) and this reactivity ensures the characteristic development of the protective patina but can on occasion lead to uneven initial weathering and even staining. However, over time as the process continues to develop, the zinc's surface gradually takes on a more uniform colour and

finish, whilst never attaining a completely homogeneous look (just as one would hope from a naturally weathering material).



Cruise liner terminal in Getxo, Bilbao, Spain, in elZinc Natural. Left photo taken three months after opening, Right photo 18 months later.

This natural process is driven primarily by contact with the air, humidity, and rainwater, and happens in stages.

1. The zinc surface reacts with oxygen in the air to form a thin layer of zinc oxide, ZnO .

2. Rainwater, and in a slower way, humidity, interact with the zinc oxide layer to form a layer of zinc hydroxide, $Zn(OH)_2$.

3. CO_2 in the air continues the patina development by forming the definitive patina which ends up being a mixture of basic zinc carbonate $Zn_5(CO_3)_2(OH)_6$ and zinc hydroxide, the proportion of which depends on the local atmospheric conditions - humidity, pollution etc.). The final appearance of the zinc depends on these environmental conditions.



Obviously, areas sheltered from the rain can take considerably longer to weather than areas exposed to the rain, but in time the different appearances weather out. The time zinc needs to take on a generally uniform appearance will vary and depends on:

- The weather conditions right after installation when the zinc is first exposed
- The location's micro-climate (particularly rainfall and humidity)
- The location's air quality (the more polluted the air, the quicker zinc weathers)

Other factors such as general building dust from nearby building sites (especially cement dust) and salt from sea spray or winter road de-icing can affect the surface of the zinc, which may require cleaning from time to time to prevent deposits from forming on the zinc surface.



Photos showing early evolution of elZinc®

Flat pitched roofs allow individual rain drops to have an effect and can begin the weathering process showing dark stains at the spots where the raindrops dried out.



These dark spots will gradually disappear as the weathering proceeds.

It is important to note that the definitive patina does not form if the surface is continuously wet, since the CO₂ does not have the chance to complete the final phase. This can lead to severe cases of white rust and can cause corrosion of the zinc from the topside, or in the case of moisture trapped beneath the zinc, from underneath causing underside corrosion. For this reason, properly designed roof and wall build-ups are essential to prevent the underside of the zinc from being constantly wet.

Specific weathering by finish - elZinc Slate®

This surface is pre-patinated to an appearance very similar to that of naturally weathered zinc. As such, it avoids the initial differences in appearance that natural zinc can exhibit, and is therefore especially suitable for façade work, soffits, or any project where a uniform finish is required right after installation. It has a real patina surface and therefore reacts with its local environment, changing slightly in composition as time passes by to more closely approach the composition (and therefore colour) of naturally patinated zinc in the same area.

This process means that any slight colour differences between panels will weather-out over time, eventually to the extent that the difference is no greater than that produced by natural weathering effects between initially identical panels.

The Slate finish cannot flake, peel, blister or chalk.

Specific weathering by finish - eZinc Graphite®, eZinc Oliva®, eZinc Lava®, eZinc Crystal®.

These surfaces are pre-patinated to various shades of grey, and in the case of Graphite, to an almost anthracite finish. The finishes are real patinas and as such will interact with the air, humidity and rainwater that comes into contact with it. Sheltered areas will weather more slowly than exposed areas. A very gradual lightening of the surface may occur after long time periods, save in the case of eZinc Crystal® which may tend towards a slightly darker shade of grey over time.

Any slight colour differences between material produced in different production batches will soon fade out as the pre-patinated layer begins to weather.

None of the above finishes can flake, peel, blister or chalk.

Specific weathering by finish - eZinc Rainbow®.

This range of subtly coloured finishes uses mineral pigments as the colouring agents. These pigments are not affected by UV radiation, and so do not fade when exposed to sunlight. A 35micron organic coating that protects the surface from the weather, provides outstanding additional corrosion resistance. Indeed, the eZinc Rainbow® finish has been tested to be categorised as a RC5 (Resistance to Corrosion), Ruv4 (Resistance to UV radiation) finish. Thus, the weathering of the surface is very slow and over the majority of the product's lifetime we estimate that the surface will only show a gradual decrease in gloss and later on possibly some decrease in colour intensity (due to gradual erosion of the pigments over the decades). Any weathering will probably be most appreciable on roofing and south facing walls (north facing in the southern hemisphere). Areas sheltered from the worst of the weather (rain and sun) will retain their initial appearance even longer.

Specific weathering by finish – eZinc Advance®.

This finish is recommended to give extra corrosion resistance to the pre-weathered eZinc Alkimi® range in harsh coastal environments. It provides a barrier between the patinated finish and airborne salt, preventing salt deposits from chemically binding to the zinc and causing corrosion issues where salt deposits have accumulated. This barrier effect slows down the natural effects of the weather on the patinated finish, keeping the appearance of the material very close to that present right after installation for a much longer period of time.

White rust.

On occasion, a white oxidation of the surface can take place during the initial phase of weathering of elZinc® Natural. This is due to the formation of zinc hydroxide ($Zn(OH)_2$) on its surface which is often caused by continuously damp and humid weather conditions just after installation, or repeated and prolonged pooling of water due to a lack of a fall, preventing drying cycles of the zinc surface from occurring and therefore preventing air from interacting with the zinc surface for long periods. With time, this layer is gradually replaced with the definitive zinc patina.



A light layer that will develop a normal patina over time.



A more severe case due to ponding. Cases like this should be removed as soon as possible after they are detected.

It is these initial weathering characteristics of Natural zinc that make pre-weathered zinc the preferred option for façade cladding - on façades - any differences in weathering will take longer to even out than on a roof, and of course they are much more noticeable.





TOP SIDE UP
Lifts SAFEST
FACE FORWARD



HANDLE WITH CARE
DO NOT EXCEED WEIGHT
OF FORKlift



TOP SIDE UP
Lifts SAFEST
FACE FORWARD



HANDLE WITH CARE
DO NOT EXCEED WEIGHT
OF FORKlift



07

STORAGE AND TRANSPORTATION

Reception in warehouses of materials from elZinc®

Coils should be unpacked and carefully inspected for visible defects.

In winter months unpacking should be carried out immediately after unloading and placing within the warehouse, allowing any condensate which may form to evaporate.

Storage in the warehouse

- For products with protective film, the storage shelf life of the zinc material is limited by that of the protective film applied to its top surface. At the time of writing this is 8 months after dispatch from elZinc®. Beyond this time, plus the maximum time allowed for the film to remain on the zinc after installation, the film can become difficult to remove and may leave behind adhesive residue which is difficult to clean
- The material should be stored in a well ventilated, dry space.
- Any changes in temperature should be gradual, to prevent condensation forming on the surface of the zinc (preferably in a temperature-controlled environment).

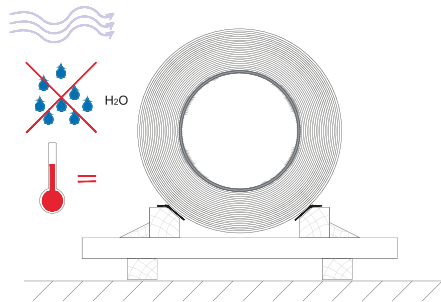

Stacking and moving of palletised materials

Sheets – we do not recommend that 1 ton pallets be stacked more than 10 high due to questions of stability (health and safety), and because the flatness of the sheets could be affected. Maximum of two stacked pallets when moving using fork-lift trucks.

Small coil pallets (≈ 100kgs each coil) – we do not recommend that pallets of small coils be stacked more than 2 high due to questions of stability (health and safety). Move individually by fork-lift truck

The above guidelines regarding stacking and moving materials are general in nature and must be checked by the responsible party in each case.

Storage on the building site

Inside

Correct storage on the building site is important to keep the material surface in perfect condition before installation - stone, cement and plaster dust can contaminate the surface in a lasting way. We recommend the following practices are adopted.

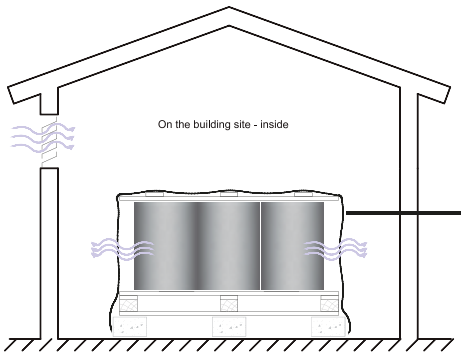

Breather membrane – protects from dust, lets water vapour pass through. Must be air gap between the zinc and the breather membrane

General notes:

- Store in a well vented space, at least 10cms off the floor, protected from rain, and protected from construction dust by a breather membrane.
- Avoid storing in newly built rooms smelling strongly of fresh concrete that is still drying out, as aerosols + humidity can cause slight discolouration of the surface.
- Avoid storing close to areas used by other trades that create a lot of dust.

Notes for winter:

- Cold air should not fall directly on the zinc.
- Material cold from transportation should not be placed in warm, humid spaces, as condensation forming on the zinc surfaces is likely. This applies even if the space is not heated. Packing should be unwrapped to let this condensation evaporate quickly, before covering again loosely with a breather membrane.
- Large coils take a long time to warm up, so transporting large coils to site in cold weather and placing them in a warmer humid room should be avoided as a matter of course.

Outside

Before zinc is installed, its surfaces can be vulnerable outside. Take special care to make sure it is properly protected.

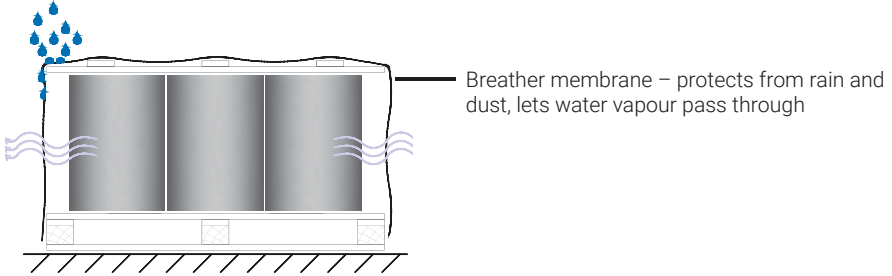

Notes:

- The zinc should be protected from rain and dust by a breather membrane, wrapped over the material in such a way as to provide a generous air gap between it and the zinc.
- Wooden pallets should be placed on non-absorbent footings.
- Outside storage should be limited to as short a time period as possible.



The effect of deficient protection allowing moisture in between windings on a coil prior to installation. The same effect is possible wherever water is trapped for long periods, and even if the stains do not immediately appear after installation, the route cause is clear.

Prefabricated products – outside

Generally these elements should be stored vertically, or individually in the horizontal just before fixing (not stacked on top of one another) making sure that rainwater can drain off their surface.

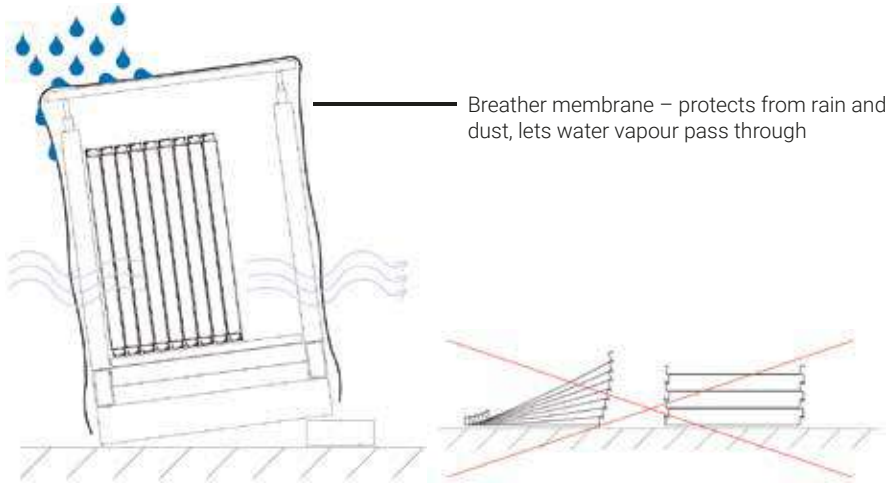

Notes:

- Store trays and panels vertically, preferably on a fully supporting base to avoid deforming them.
- Protect with a breather membrane, making sure rainwater drains off the crate.
- Take out of internal storage only the material planned to be installed that day.
- If trays, panels etc. must be left outside overnight, make sure they are securely covered.
- If trays, panels etc. must be left on the roof overnight, make sure they are securely held down, and properly covered

Prefabricated products – inside

- Follow the same guidelines applicable to coil.
- Store trays and panels vertically, preferably on a fully supporting base to avoid deforming them.

Transportation to the building site

The material should be properly protected from the weather, and securely packed to avoid damage during transport, even on short journeys. Protection during longer journeys should allow any condensation that forms during transportation to evaporate.

Unloading on the building site

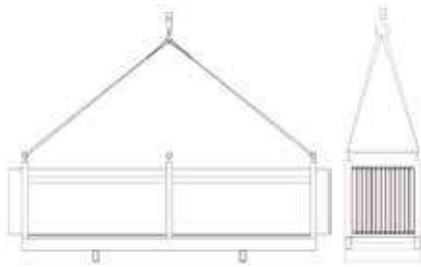

Notes:

- Long trays and panels are best offloaded using crates. These can be used for site storage, and collected later for re-use.

Handling and carrying trays and panels

Careless handling can introduce kinks, buckling and general unevenness in the trays. Follow the instructions below to minimise this.

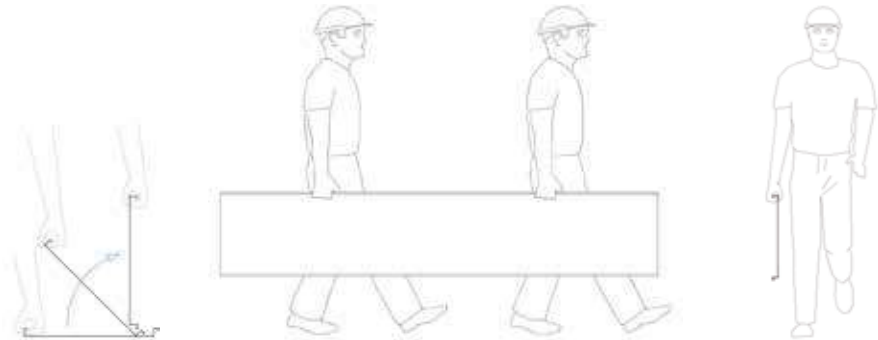

Notes:

- Pick up trays and shingles lifting from the centre of one side first, to the vertical.
- Carry trays, shingles and panels in the vertical to avoid buckling of the seams or hems. Shingles are especially easy to buckle. Avoid moving long pieces in windy weather.
- Long trays, panels etc. are to be held every 3m maximum. Shingles every 2m.





08

WORKING AND PROCESSING



Folding and bending eZinc®

eZinc® has particularly good malleability, but some precautions should be taken when working with the material. In general it is good practice to 'leave a radius' on folds wherever possible, and when bending thicker material, (over 1mm), tight folding should be avoided, whether executed using a folder in the workshop or on site by hand. The minimum recommended inside bending radii, irrespective of rolling direction are shown below.

eZinc Alkimi®

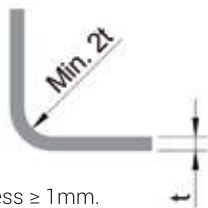

eZinc Rainbow® / eZinc Advance®

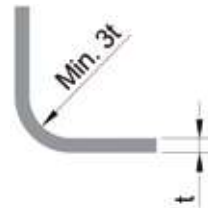

t = material thickness \geq 1mm.

Notes:

- If extra-thick material is required (for example to fabricate single skin cassette panels) consult eZinc® beforehand.
- When marking out using a scribe, take care not to apply too much pressure as deep score lines can facilitate crack formation



with appropriate care



Working in cold weather.

Zinc becomes brittle when its temperature falls below 10°C (50°F). European trade guidelines take this into account by stating that zinc must not be worked when its temperature falls below this value.

However, due to the special eZinc® rolling process and cutting-edge manufacturing plant, eZinc® can be safely worked slightly below this temperature.

The following table is a summary of cold working operations possible with eZinc®.

Finish	Sheet temp. (t)						
	t ≤ 7°C		7°C < t ≤ 10°C			10°C < t	
	eZinc® Natural eZinc Slate® eZinc Rainbow®		eZinc® Natural eZinc Slate® eZinc Rainbow®			eZinc® Natural eZinc Slate® eZinc Rainbow®	
Thickness (mm)	≤ 0,7	≥ 0,8	≤ 0,7	0,8	≥ 0,8	≤ 0,7	≥ 0,8
Profiling standing seam, batten roll	Warm Up	Warm Up	Yes		Warm Up	No measures required to be taken - eZinc exhibits good workability	
Bending	Warm Up	Warm Up	Up to 135°	Up to 90°	Up to 135° but warm up		
Seaming up angle seam	Warm Up	Warm Up	Close seam carefully avoiding abrupt folding		N/A		
Warm up notes							
eZinc Natural	Warm up until "warm to the touch" when metal is worked using "winter set", heat gun or a weak flame.						
eZinc Alkimi, eZinc Rainbow and eZinc Protect+	Warm up until "warm to the touch" when metal is worked using "winter set" or heat gun						

Notes:

- The indicated temperature is that of the zinc, not the air temperature.
- Zinc coils or closely stacked sheets taken from storage early on cold mornings can take a while to heat up outside, as its thermal inertia is considerable.
- If in doubt, check the temperature of the metal (by using a thermometer strip for example).
- When working in cold weather it is important to take into consideration how much the zinc will expand in warmer weather – this is especially important when installing long trays or panels. The reverse is also true





09

CLEANING AND MAINTENANCE

elZinc® roofing and cladding products are low-maintenance materials. They generally do not require any particular attention from the building owner and will give a long and cost-effective service life looking good and protecting the building from the weather for many decades. The following recommendations are given below to enable these expectations to be fully met by our products.

During the life of the elZinc® cladding

General

Visual inspections should be carried out annually, as well as just after any other works have been completed to other parts of the building that have required access to the roof and could have caused some damage to it in that area.

General cleaning of gutters, rainwater pipes and other elements that channel rainwater should be carried out periodically in order to avoid the build-up of soil deposits and general debris. This also maintains the water course's ability to drain the roof effectively.

Rain protected areas.

Areas of roofs or cladding that are protected from rainwater do not benefit from the natural washing qualities of rainfall, and therefore dirty deposits can accumulate over time. These areas should simply be washed with warm water, as regularly as is required to keep the overall cleanliness of the building as desired.

In coastal areas the zinc cladding should be kept clean of salt deposits, as should any cladding susceptible to salt deposit build-up generated by winter road salt spray near to main roads. The build-up of salt deposits on rain-protected areas produces a very corrosive effect on the zinc especially if the air is locally contaminated from industrial pollution, which can limit its lifespan considerably so we strongly urge that these sheltered areas of cladding are maintained salt-free.

Subsequent installation of machinery or other attachments to the roof.

Attachment points of Hvac equipment fitted subsequently should respect the functionality of the roof (for example regarding thermal movement) and any layers important to the general performance of the roof such as vapour barriers and separating membranes that have been perforated by the installation, should be properly and effectively sealed.

Damaged panels.

Zinc is a naturally weathering material and most minor imperfections such as light scratches and abrasions will self- heal over time. Unless these imperfections are too unsightly to tolerate, no action is necessary. Any seriously damaged panels however should be repaired immediately by a specialist zinc metal roofing contractor.

- Storm damaged panels should be replaced and adjacent panels checked.
- Perforated panels (arising from any subsequent works) should be repaired by soldering a cover piece over the area.
- Dented areas (from access ladders for example) should also be repaired in the same way if rainwater does not completely drain from the dent for long periods of time.
- Deformed and trodden-down standing seams caused by foot traffic should be corrected.

All repairs should be carried out according to elZinc®'s general installation guidelines and the zinc of existing panels should be heated if required to facilitate re-forming. The correct functioning of the repaired cladding in regard to thermal movements should be checked.

Replacement panels can be expected to have a slightly different colour tone to the surrounding panels. These tonal differences can be expected to reduce over time, the speed with which this happens depends on the finish of the material.

Graffiti removal

Graffiti can be effectively cleaned from some elZinc® surfaces but not from others. If graffiti removal is considered likely to be a frequent requirement, the most effective way to protect elZinc® from graffiti is to apply a sacrificial layer after installation. This layer, which when washed off with hot water, takes the graffiti with it. It is then re-applied. There are products on the market that are easy to apply and re-apply – please contact us for more information. Written authorisation should be sought from elZinc® before application of the chosen treatment so as not to invalidate the product warranty.

Cleaning of elZinc®

The following table shows recommended methods for cleaning marks and stains on our products, both caused during the installation/construction process and afterwards. We recommend testing the procedure on a hidden area beforehand. If the procedure does not produce satisfactory cleaning, please contact your distributor. The reader is reminded that abrasive materials such as steel wool can be used to remove stubborn stains as an ultimate recourse only on elZinc® Natural – the use of abrasive materials on any other finish will damage the surface. This will leave a bright zinc finish that should be treated with titanium zinc passivating oil.

Stain, mark to be removed	elZinc® finish	Step 1		Step 2	
		Cleaning products	Procedure	Cleaning products	Procedure
Salt deposits	All finishes	Warm water (cold Works less well)	High pressure washing using a fan nozzle, directed downwards and at an angle to the cladding (to avoid mechanically deforming the panels) from about 20cms away. Max pressure below 60 bar.	Not Applicable	Not Applicable
Fat and oil residue	All finishes	Lukewarm water + neutral soap	Wipe with a soft sponge or cotton cloth. Rinse thoroughly from top to bottom to remove soap residue, taking care not to force water into joints between panels.	Diesel	Apply with a cotton cloth and repeat step 1
Graffiti, paint residue	elZinc Natural elZinc Slate elZinc Rainbow elZinc Advance	Lukewarm water + neutral soap	Wipe with a soft sponge or cotton cloth. Rinse thoroughly from top to bottom to remove soap residue, taking care not to force water into joints between panels.	Graffiti remover 1500 of brand 3M	Spray and wait a few minutes, gently wipe with a cotton cloth and repeat step 1
	elZinc Graphite elZinc Crystal elZinc Oliva elZinc Lava			Not possible to eliminate without damaging the elZinc® surface	Not Applicable
Light spots and dust	All finishes	Lukewarm water + neutral soap	Wipe with a soft sponge or cotton cloth. Rinse thoroughly from top to bottom to remove soap residue, taking care not to force water into joints between panels.	Not Applicable	Not Applicable

Stain, mark to be removed	elZinc® finish	Step 1		Step 2	
		Cleaning products	Procedure	Cleaning products	Procedure
Bird droppings, gypsum¹, cement¹, fingerprints	All finishes	Lukewarm water + neutral soap	Wipe with a soft sponge or cotton cloth. Rinse thoroughly from top to bottom to remove soap residue, taking care not to force water into joints between panels.	Diesel	Apply with a cotton cloth and repeat step 1
Missed flux residue²	All finishes	Lukewarm water + neutral soap	Wipe with a soft sponge or cotton cloth. Rinse thoroughly from top to bottom to remove soap residue, taking care not to force water into joints between panels.	Not Applicable	Not Applicable
Brown or olive brown stains from unprotected bitumen roofs, PVC coated areas	All finishes	Lukewarm water + neutral soap	Wipe with a soft sponge or cotton cloth. Rinse thoroughly from top to bottom to remove soap residue, taking care not to force water into joints between panels.	Pronto furniture polish (Johnson) or Diesel	Spray and wait a few minutes, gently wipe with a cotton cloth and repeat step 1 or Apply with a cotton cloth and repeat step 1

1. Much easier to remove if still fresh, so remove as soon as possible.

2. Flux residues should be removed immediately after soldering with a damp cloth, as soldering proceeds.

Stain, mark to be removed	elZinc® finish	Step 1		Step 2	
		Cleaning products	Procedure	Cleaning products	Procedure
Zinc hydroxide White rust	elZinc Natural light rust	Brush off	Use a stiff non-metal bristled brush to remove white deposits	Clean warm water	Rinse to remove any powder cloth and repeat step 1
	elZinc Natural heavy rust	Hard brush off	Use stainless steel wool or corun dum fleece for mild abrasive cleaning	Clean warm water	Rinse to remove any powder (possibly treat with passivation oil)
	elZinc Alkimi®	Unlikely to be affected, but not possible to remove without damaging the elZinc Alkimi® prepatinated layer			
	elZinc Rainbow® elZinc Advance®	These surfaces are unaffected by white rust			
Adhesive residue	All finishes	Lukewarm water + neutral soap	Wipe with a soft sponge or cotton cloth. Rinse thoroughly from top to bottom to remove soap residue, taking care not to force water into joints between panels.	Pronto furniture polish (Johnson)	Spray and wait a few minutes, gently wipe with a cotton cloth and repeat step 1
		If the above steps are not sufficient to remove the adhesive residue, this is indicative of the presence of additional types of deposits (particles, dust, etc.) from the environment, in which case the surface should be cleaned with STO-ULTRA CLEANER spray using a soft sponge or cotton cloth. The amount of product required is approximately 1.5 L/10m ²			

The aforementioned general guidelines are recommended to get the most out of elZinc® products, but the influence of unforeseeable agents or contaminants in the atmosphere could result in the material being affected in other ways.







10

COMPATIBILITY WITH OTHER BUILDING MATERIALS

Not all building materials are compatible with one another and care needs to be taken when selecting material to be in contact with, or draining onto, zinc roofing or cladding. The ill effects of not doing this can vary from light staining of the surface of the zinc to complete corrosion, so it is important that these potential hazards are designed out from the beginning. Natural zinc is the most affected, especially prior to forming its protective patina. These pages serve as a guide to avoiding the consequences of damage to our products from such causes, allowing architects to 'design out' such risks. The material lists in the tables below are not exhaustive - please contact elZinc if a condition arises on a project that is not among those below.

Metals

Different metals placed in contact with each other on the exterior of buildings must be compatible in order to avoid galvanic corrosion (also known as bi-metallic corrosion). Whether metals are compatible with one another depends on two factors:

1. The difference in their electrochemical potential (whether they are anodic, give electrons and corrode or cathodic, receive electrons and are protected from corrosion). If the difference is over $\approx 400\text{mV}$, in the presence of water (an electrolyte) a galvanic reaction will begin and cause the anodic metal to corrode faster than it ordinarily would. The greater the difference in electrochemical potential, the faster the anodic metal corrodes.

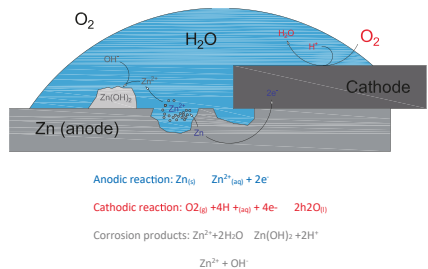

2. How effectively surface coatings can prevent a galvanic cell from forming, thus eliminating the corrosion at the anode, depends on their ability to act as an electric insulator.

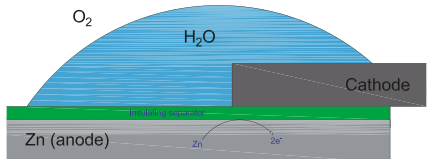

elZinc natural has no surface finish, and the pre-weathered finishes in the elZinc Alkimi® range are thin, conductive layers that do not inhibit galvanic corrosion. elZinc Rainbow®, elZinc Advance® and elZinc Protect+® on the other hand are thicker non-conductive layers and prevent galvanic corrosion.

It is also possible for cathodic metals to harm zinc if run off from them is allowed to drain onto the zinc. For example, copper roofs can be placed under zinc roofs with no damage occurring to the copper, but zinc roofs under copper would suffer accelerated corrosion. The table below indicates the effect of metals commonly used in construction on elZinc® products.

Compatibility	elZinc® finish							
	Direct contact				Run off onto zinc			
Metals	elZinc® Natural	elZinc® Alkimi pre patinated	elZinc Rainbow® elZinc Advance®	elZinc Protect+®	elZinc® Natural	elZinc® Alkimi pre patinated	elZinc Rainbow® elZinc Advance®	elZinc Protect+®
Zinc	N/A	N/A	N/A	N/A	N/A	N/A	N/A	N/A
Galvanised steel	OK	OK	OK	OK	OK	OK	OK	OK
Steel (non-galvanised)	Causes corrosion	Not allowed if steel unprotected	Pending study	Pending study	Causes corrosion	Causes corrosion	Possible staining	OK
Steel sheet, lacquered	OK	OK	OK	OK	OK	OK	OK	OK
Cast iron	1	1	OK	OK	OK	OK	OK	OK
Stainless steel	1	1	OK	OK	OK	OK	OK	OK
Copper and copper alloys	Causes corrosion	Prohibited	Prohibited	Prohibited	Causes corrosion	Causes corrosion	Pending study	Pending study
Lead	OK	OK	OK	OK	Possible staining can be reduced by applying patinating oil on the lead	Possible staining can be reduced by applying patinating oil on the lead	Possible staining can be reduced by applying patinating oil on the lead	Possible staining can be reduced by applying patinating oil on the lead
Aluminium, bare metal	OK	OK	OK	OK	OK	OK	OK	OK
Aluminium, anodised	OK	OK	OK	OK	OK	OK	OK	OK
Aluminium, lacquered	OK	OK	OK	OK	OK	OK	OK	OK

1.OK if the surface ratio of the zinc with the other metal is sufficiently high - zinc sheet fixed with stainless steel screws for example. Potentially problematic if this ratio is unfavourable.

The more conductive the water (electrolyte) the faster the anodic metal will corrode. Salt water conducts electricity better than rainwater, so should galvanic corrosion occur it will be more serious in coastal environments than inland.

General recommendations for rural, urban and industrial atmospheres.

All elZinc® products can be placed in contact with the following metals, and with no effect on either metal:

- All types of aluminium, whether untreated, anodised or lacquered.
- Stainless steel, unless the surface ratio of zinc to stainless is very small (small zinc elements on a stainless steel roof). Stainless steel fasteners used on zinc roofs are perfectly ok.
- Lead (with patination oil applied). Un-treated lead may cause staining.
- Galvanised steel sheet (galvanised coating at least 20 microns thick on both sides). It is completely compatible and is used in many details to provide support for zinc flashings, cappings and profiles. For very corrosive atmospheres, coatings made from zinc aluminium alloys offer greater resistance to corrosion and should be considered, for example Galfan (5% Al) and Aluzinc (55% Al) coatings.

elZinc® products should never be placed in contact with

- Copper or copper alloys (brass and bronze).
- elZinc® Natural and pre-patinated products should never be placed in contact with unprotected steel or iron unless the surface ratio of the steel or iron is very small with respect to the zinc.

If appropriate, separating cathodic metals from zinc with a gap joint must be done such that capillary action does not draw in moisture and risk starting gap corrosion. Gap corrosion is not dependent on the presence of a cathodic metal, but if it forms it can magnify the severity of contact corrosion.

elZinc® Natural and elZinc Alkimi® finishes must not drain rainwater from:

- Copper or copper alloy roofs.
- Iron profiles or unprotected steel flashings etc.

If in doubt, seek the advice of your elZinc® distributor or contact elZinc® direct.

Timber

Timber is also a natural material and combines well aesthetically with zinc on façades. Some species of timber (softwoods) are used as a substrate for zinc roofing and are completely compatible with zinc. Other timber products (plywood, OSB) are also used as a substrate but require a separating layer between them and the zinc.



However, not all wood is alike. Many species of timber are used in construction and some can cause staining of zinc surfaces, or in some severe cases, corrosion. These are species that have a low pH value, such as hardwoods and tropical woods. The compatibility with elZinc® products of commonly used species is given below.

Compatibility	elZinc® finish							
	Direct contact				Run off onto zinc			
	elZinc® Natural	elZinc® Alkimi pre patinated	elZinc Rainbow® elZinc Advance®	elZinc Protect+®	elZinc Natural	elZinc® Alkimi pre patinated	elZinc Rainbow® elZinc Advance®	elZinc Protect+®
Timber								
Pine (Norway pine (picea abies), Scots pine (pinus silvestris) European Silver Fir (abies alba)	OK	OK	OK	OK	OK	OK	OK	OK
Spruce	OK	OK	OK	OK	OK	OK	OK	OK
Fir (red and white)	OK	OK	OK	OK	OK	OK	OK	OK
Poplar	OK	OK	OK	OK	OK	OK	OK	OK
Tropical woods	Causes corrosion	Causes corrosion	Potential corrosion	OK	Causes corrosion	Causes corrosion	Potential corrosion	OK
Douglas pine	Causes corrosion	Causes corrosion	Potential corrosion	OK	Causes corrosion	Causes corrosion	Potential corrosion	OK
Larch	Causes corrosion	Causes corrosion	Potential corrosion	OK	Causes corrosion	Causes corrosion	Potential corrosion	OK
Oak	Causes corrosion	Causes corrosion	Potential corrosion	OK	Causes corrosion	Causes corrosion	Potential corrosion	OK
Chestnut	Causes corrosion	Causes corrosion	Potential corrosion	OK	Causes corrosion	Causes corrosion	Potential corrosion	OK
White and red cedar	Causes corrosion	Causes corrosion	Potential corrosion	OK	Causes corrosion	Causes corrosion	Potential corrosion	OK
Softwood plywood class 2 to EN636	OK	OK	OK	OK	N/A	N/A	N/A	N/A
OSB class 3 to EN300	OK	OK	OK	OK	N/A	N/A	N/A	N/A

1 – Protect+ is usually used as an underside protection, but can also be applied to the top surface in extremely aggressive situations (direct sea splashing)

General recommendations:

All elZinc® products can be used without reservation with Norway pine, Scotts pine, European silver fir, Spruce, red and white fir and Poplar. These would be typically used as the timber in open gap boarding substrates, without a separation layer between the zinc and the wood.

All elZinc® products can be used without reservation with softwood plywood (class 2) and OSB (class 3), which would be used as the sheathing substrate with a breather membrane (and possibly a structural mat) placed between the zinc and the sheathing.

Tropical hardwoods, oak, red & white cedar, larch, chestnut and Douglas pine should not be in contact with or shed run-off onto elZinc® Natural or pre-patinated. Contact is OK for the remainder of elZinc® products, but run-off can cause some staining.

Wood preservatives.

These days wood preservatives pose few problems for zinc roofing and cladding. Pressure impregnated systems are normally stable and will not affect elZinc®. Organic products and emulsions can be used. Non-fixed metal salts are incompatible as the release of the metals they use (such as copper) can harm the zinc.

Compatibility	elZinc® finish							
	Direct contact				Run off onto zinc			
Timber	elZinc® Natural	elZinc® Alkimi pre patinated	elZinc Rainbow® elZinc Advance®	elZinc Protect+®	elZinc® Natural	elZinc® Alkimi pre patinated	elZinc Rainbow® elZinc Advance®	elZinc Protect+®
Light Organic Solvent Preservatives.	OK	OK	OK	OK	OK	OK	OK	OK
Emulsions	OK	OK	OK	OK	OK	OK	OK	OK
Fixed metal salts (CCA and CCB)	Pending study	Pending study	Pending study	Pending study	Pending study	Pending study	Pending study	Pending study

Cementitious materials

Cement

Portland cement is used as the binder in most types of mortar, grout, render (stucco) and concrete. Amongst other ingredients, cement contains lime (calcium oxide - CaO) and calcium silicate (Ca2SiO4) that can attack zinc when fresh. This attack is due to the high pH values of excess water as long as the cement is not yet fully cured. This can take many months and even years to happen. Even rain run-off from apparently totally cured cement components can have a high enough pH to affect zinc.

Plaster of Paris.

Plaster is made of gypsum (Calcium Sulphate dihydrate – CaSO4 2H2O) that has been heated to 'dry it out'. When combined with water it quickly reverts back to gypsum, and does not pose a problem to zinc precisely due to its fast curing time.

Fibre cement boards.

Cutting fibre cement boards produces cement dust that if allowed to settle onto zinc roofs in humid conditions, or it rains afterwards, can cause lasting staining on elZinc Natural and Alkimi-pre-patinated products.

Magnesium oxide boards.

These boards have many qualities that make them ideal for sheathing behind zinc, not least of which is that they are A1 fire rated. However, some brands of boards in certain conditions (high humidity) can release corrosive salt-laden water droplets that can damage zinc roofing and cladding. Consult elZinc for more information.

Compatibility	elZinc® finish							
	Direct contact				Run off onto zinc			
Cement type products	elZinc® Natural	elZinc® Alkimi pre patinated	elZinc Rainbow® elZinc Advance®	elZinc Protect+®	elZinc® Natural	elZinc® Alkimi pre patinated	elZinc Rainbow® elZinc Advance®	elZinc Protect+®
Concrete, mortar, render (stucco).	Causes corrosion	Causes corrosion	Causes corrosion	OK	Causes corrosion	Possible staining	OK	OK
Plaster of Paris	OK	OK	OK	OK	N/A	N/A	N/A	N/A
Fibre cement boards	OK	OK	OK	OK	N/A	N/A	N/A	N/A
Magnesium oxide boards	Causes corrosion	Causes corrosion	OK ¹	OK	N/A	N/A	N/A	N/A

¹ If certain conditions are met regarding the vapour tightness of the under construction



Corrosion of a zinc wall capping fixed directly over a cementitious material – easily and economically avoided by the use of a structural underlay (mat + breather) installed under the zinc

General recommendations

eZinc® Natural and pre-patinated finishes should not be allowed to come into contact with fresh concrete, mortar or render (stucco). Once fully cured there are no negative effects, but the zinc should be separated by a breather membrane and structural underlay (mat) if being installed on top.

Mortar, render, concrete splashes should be washed off as soon as detected – see cleaning and maintenance guide – pages 63.

Re-pointing brickwork above zinc flashings should be done with compatible sealants – see below.

Rendered walls above zinc roofs should use a lacquered or anodised aluminium angle at the bottom edge.

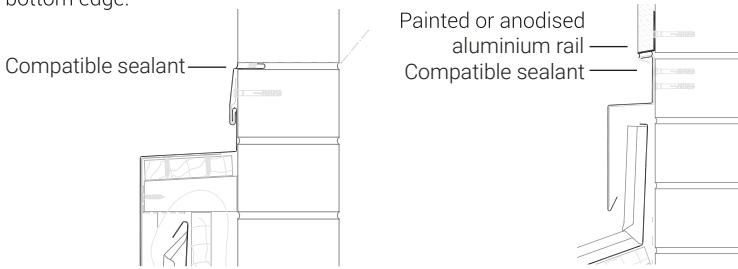

Bituminous products, sealants, adhesives and tapes

Bituminous products

Bituminous membranes breakdown on exposure to the sun. The breakdown products contain acids which can corrode zinc badly, eating through it in a matter of months.

Sealants, adhesives and adhesive tapes

Two component acid system sealants can cause severe corrosion and staining of eZinc® products and should not be used. Neutral curing mastics and silicones are fine with all products, as are Polyurethane based sealants and MS polymer sealants. For colour matching the sealant to an eZinc® product, please refer to page 24.

Sometimes an adhesive is required to attach accessories (such as the bird spikes below). Neutral curing silicones, MS polymers and polyurethane based adhesives are all compatible with eZinc® products.



Bird spikes attached using neutral curing silicone



Aluminium window frame sealed against the eZinc Rainbow Brown sill using brown neutral curing silicone

Adhesive tapes can be used to attach other elements to zinc roofing or wall cladding. If exposed to sunlight they may degrade over time, and the compounds released may harm the zinc. However, GPH 160 3M tape is suitable as long as the surface of the zinc is prepared using primer 3M AP111. Consult elZinc® for the compatibility of other adhesive tapes.

Compatibility	elZinc® finish							
	Direct contact				Run off onto zinc			
Miscellaneous	elZinc® Natural	elZinc® Alkimi pre patinated	elZinc Rainbow® elZinc Advance®	elZinc Protect+®	elZinc® Natural	elZinc® Alkimi pre patinated	elZinc Rainbow® elZinc Advance®	elZinc Protect+®
Bitumen membranes	1Causes corrosion	1Causes corrosion	Possible staining	Possible staining	Possible corrosion if bitumen is unprotected from sunlight.		Possible corrosion if bitumen is unprotected from sunlight.	
Acetoxy or acetic acid system sealants	Causes corrosion	Causes corrosion	Possible staining	Possible staining	Causes corrosion	Causes corrosion	Possible staining	Possible staining
Neutral curing sealants	OK	OK	OK	OK	OK	OK	OK	OK
Polyurethane based sealants	OK	OK	OK	OK	OK	OK	OK	OK
MS polimers	OK	OK	OK	OK	OK	OK	OK	OK

1- When used as an adhesive, fully bonding the zinc to its substrate and water cannot penetrate between the two materials, then no adverse effect is noticed.

General recommendations

Bitumen membranes draining rainwater onto zinc products should be protected from sunlight by at least 5cm of gravel.

elZinc products must be separated from direct contact with bitumen membranes by a suitable separation layer.

Consult elZinc® regarding adhesives, tapes and sealants if in doubt about their compatibility.



11

COASTAL ENVIRONMENTS



elZinc® in coastal environments

elZinc® products are suitable for use in coastal areas thanks to their innate resistance to corrosion. Indeed zinc has been used successfully for decades in some of the harshest coastal locations, due to its attractive appearance, light weight, ability to resist gale force winds and of course its durability.



Old zinc roofs
on Eastbourne
Pier, England.

However, using zinc in coastal areas, (which, from an air salinity point of view can be considered to be within 1,5kms from the sea shore) and especially very near coastlines where breaking surf is common, requires some precautions to be taken into account if it is to give its full potential. The problem is not the general aggressiveness of the salty air, the problem is the uncontrolled natural build-up of salt deposits on the zinc's surface, which if left unchecked can lead to ugly staining and indeed corrosion of the zinc. On rain-washed areas in temperate climates this is not a problem, as the rainwater prevents salt deposits from building up. But on rain-protected areas of cladding, drip edges where rainwater dwells for a longer period of time, and in general in climates where rainfall is infrequent, salt deposits can start to build. Salt deposits on zinc are white and have a pebbly texture like coarse orange-peel.



Frequently rain-washed areas do not allow salt deposits to build – elZinc Slate at Fairlight, Sydney

Therefore, the following should be taken as general advice.

1. In areas of low salinity, (calm waters, bays) detail out rain-protected areas of zinc cladding:

- A. As far as possible, avoid overhangs that shelter zinc roofing and cladding.
- B. If a zinc fascia is to be installed, use internal eaves gutters (made of elZinc Advance/Rainbow for added protection) instead of hanging eaves gutters that will shelter the fascia.
- C. Avoid horizontal angle seam wall cladding.

2. In areas of high salinity (beaches or rocky shores with breaking surf) use the correct technical finish of zinc:

Use elZinc Advance® or elZinc Rainbow® for all the roofing and cladding:

Request a sample of the Advance® finish from your local distributor as there can be some colour difference between the Advance and standard finishes

3. In extreme cases (on roofing or cladding subjected to occasional splashing by sea water during heavy weather):

Use Protect+ for all the roof or cladding in extreme circumstances to protect the under side of the zinc.

4. **Generally use lighter colours** over which any white salt staining that may occur at times is less visible.
elZinc Crystal® and/or elZinc Slate®.
5. **Use elZinc Rainbow® Black instead of elZinc Graphite®**, even on rain-washed areas, as any white salt deposits are very visible against the dark finish.
6. **The roofing and cladding** (especially drip edges and areas unwashed by rainwater) should be regularly inspected for the build-up of salt deposits, which if detected should be removed – see the section on cleaning and maintenance for the recommended removal method.



elZinc Slate® on UK Coast
Housing development, England.



The house of the edge,
Granada, Spain.

The above precautions should also be considered for zinc cladding next to busy fast roads that throw up large amounts of salt spray due to winter de-icing.





12

HOT & COLD CLIMATES



Zinc's properties allow the material to be installed in any climate region, regardless of extreme temperatures. Although sometimes care needs to be taken during installation (see our cold working regulations), once installed it is not affected either by very hot or very cold environments.



eZinc Slate®, football stadium, Montreal, Canada



eZinc Slate®, Hotel Des Montanvers, Mont Blanc, French Alps.



eZinc Rainbow® Red, Adelaide Convention Centre, Australia.



eZinc Rainbow® Brown, Private house, Kundu, Southern Turkey

Cold climates

In mountainous regions, the higher you climb the more common zinc roofs become. It is often chosen as the roofing material for ski resort hotels, mountain top restaurants, cable car stations etc.. The zinc clad Helbronner cable car station, at 3500mts above sea level in the Alps, is a good example. In other regions of world where very cold winters are the norm, zinc on the whole is much more commonly used than in most countries with a temperate climate, The Nordic countries are a very good example.

Behaviour of zinc in cold climates

- Being impervious, zinc is unaffected by freeze thaw processes that can break up other materials.
- Once installed, it is not affected by low temperatures.
- It resists strong winds common in mountainous geography.
- Enjoys a very long life.

Snow lying against the zinc for long periods of time does not affect the surface finish, be it naturally patinated or pre-weathered, but on occasion after especially snowy winters some white discoloration can be visible in the spring as the snow melts and reveals where any meltwater was retained by ice damming. This discoloration then gradually returns to the normal colour of zinc. This does not occur with an eZinc Rainbow or eZinc Advance finish.



One other effect of snow lying on a new or relatively new natural zinc roof for a few days is that it can make the patina more uniform, reducing the initial irregularity associated with naturally patinating roofs, if the snow cover is relatively even and defrosts relatively quickly.

Design considerations in cold climates

There are only two important issues that must be addressed – ice dams and snow retention.

Ice dams.

Common to roofs of all types (tiled, slated, shingled, metal etc.), ice dams are a localised build-up of ice on the roof due to melt water refreezing. This can be caused by:

- Snow melting from the underside due to heat loss thawing and freezing again at the overhanging, colder, eaves.
- Snow melt due to solar thawing draining onto shaded areas and refreezing.



This can cause the standing seams to be flooded, leading to water ingress. If there is a structural underlay with a waterproof membrane under the zinc, this will drain the water down to the cold eave, where it will freeze under the zinc.

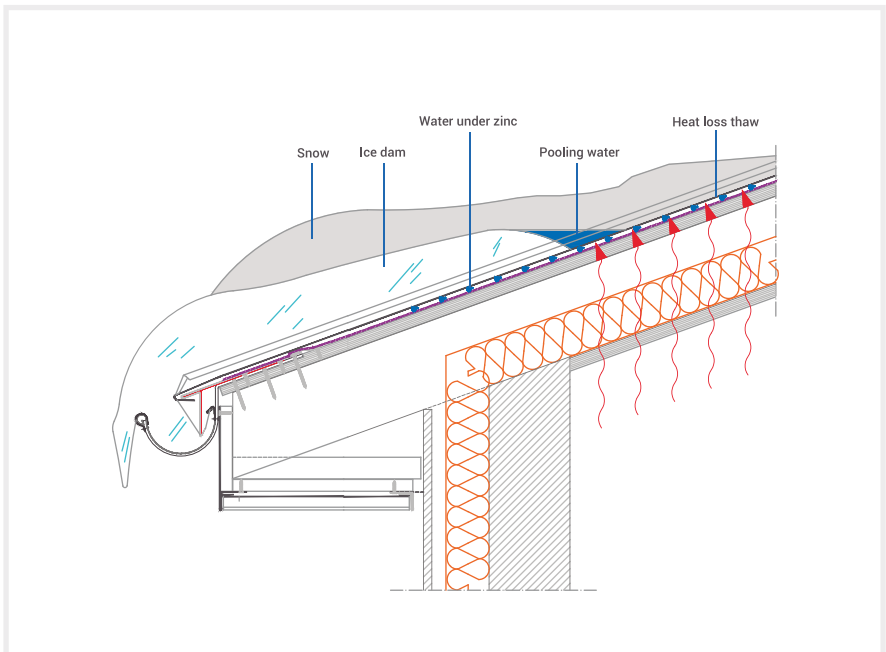

Underlying phenomena - behaviour of snow thaw on a zinc roof

Snow thaw on a metal roof can occur due to three phenomena:

- Air thaw

The air temperature is above freezing and melts the snow from the top down. Melt water will filter down through the snow layer. If the temperature drops below freezing again, a crust forms on the top layers. This type of thawing occurs from the top down, and when the underlying snow layers can no longer hold any more water, it drains away over the zinc trays.

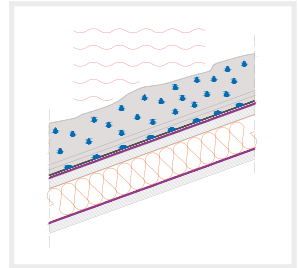

- Sun thaw

The zinc trays are heated by the un-reflected sunlight reaching them through the snow layers (snow is not opaque). The snow melts from the bottom up, some water being absorbed by the snow on top, while the remainder drains down the zinc trays. This phenomenon can occur when the ambient temperature is well below freezing, and the darker the zinc finish the greater the effect. This thawing can have two consequences:

- o As it breaks the bond between the zinc and the snow layer, it can lead to a sudden shedding of the entire snow blanket if no retention systems have been installed.

- o Flowing over shaded areas it can re-freeze and build up ice dams.

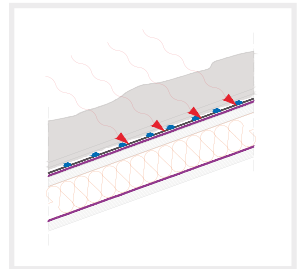

- Heat loss thaw

The zinc roofing is heated from the bottom due to escaping heat from the inside of the building. The snow melts from the bottom up, and the melt water not absorbed by the snow on top drains towards the eaves. If the outside temperature is below freezing, the melt water will re-freeze when it passes over areas of the roof with less heat loss, or over the cold, overhanging eaves of the roof.

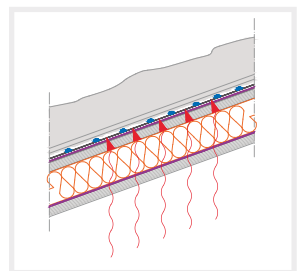

In order to minimise the formation of ice dams, the following recommendations are made:

- Insulate the roofs adequately, paying special attention to cold bridging. This will limit heat loss thaw.
- Ventilate roofs. Venting the roof keeps the zinc colder by introducing an air space between the insulation and the decking supporting the zinc. This helps to protect against heat loss thaw. There are two options here:

1. Simple vented roofs

Built either using open gap softwood boarding or wooden sheathing as the substrate. Inlets and outlets should be continuous at the eaves and ridge. Follow local and national guidelines.

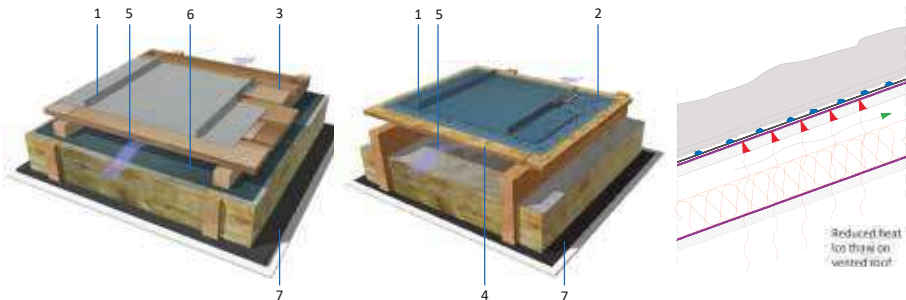

- | | | |
|---------------------------------|---|-------------------------|
| 1. eZinc® standing seam roofing | 4. Wooden sheathing | 7. Vapour control layer |
| 2. Structural underlay | 5. Ventilation gap | |
| 3. Open gap soft wood boarding | 6. Breather membrane as draining membrane | |

2. Double ventilated roofs

Used in Alpine Europe (Parts of France, Austria and Switzerland) they provide extra protection against water ingress through the standing seams. These roofs typically incorporate a bitumen based waterproofing layer over the sub-deck to drain any water ingress (that has filtered through the standing seams and dripped through the open gap boarding) or condensate away. This layer is not vapor permeable, and so must be vented underneath by the second air layer. Inlets and outlets must be continuous. Follow local and national guidelines



- | |
|--|
| 1. eZinc® standing seam Roofing |
| 2. Open gap soft wood boarding |
| 3. Ventilation gap under zinc |
| 4. Bitumen waterproofing and deck |
| 5. Ventilation gap under bitumen waterproofing |
| 6. Vapour control layer |

- If possible, design the roof so that all slopes receive at least some sun during the day (east – west facing slopes are preferable to north – south facing slopes).
- Dark colours (elZinc Graphite®, Lava, Oliva and Rainbow Brown and Black) will help absorb sunlight and induce sun thaw. Generally, this is preferable to heat loss thaw as it avoids the 'cold eave' problem that leads to eave ice dams. Dark coloured rainwater goods should also be used to avoid the meltwater freezing in gutters and downpipes.
- Seal standing seams at eaves using appropriate measures such as closed cell compressive foam strips. The sealing strips should extend well up the roof to at least 1,5mts from the eaves and in any case to beyond where there is a risk of the seams flooding. This should be carried out in all other areas where there is a risk of seam flooding.

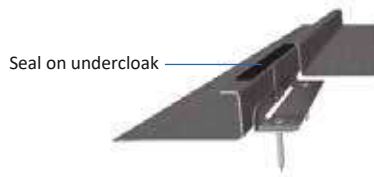

- Consider using the detail below for the foot of the standing seams – the end tabs of the seam upstands are folded back within the seam, allowing for free slippage of snow and ice.

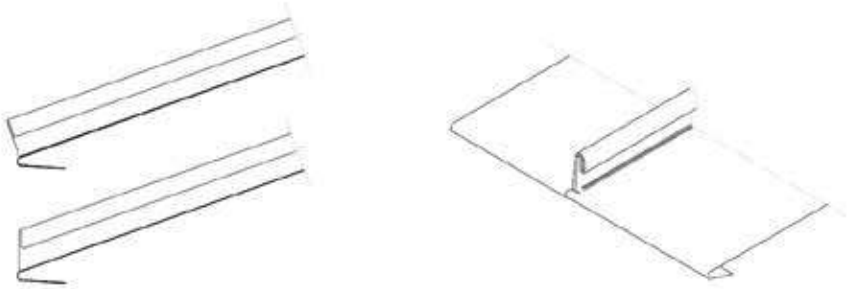

Design and installation considerations for climates with cold winters

- Snow and ice retention

The installation of a snow and ice guard system is commonplace in regions with frequent winter snow. Their function is to retain the snow on the roof until it melts away, stopping potentially dangerous slippages onto passers by below. It also protects eaves gutters from damage due to the weight of slipping snow.

- Standing seam roofing systems

These systems use aluminium pipes that are clamped to the standing seams, and therefore do not perforate the zinc or prevent the zinc bays from freely expanding and contracting due to temperature changes. One such system is shown below.

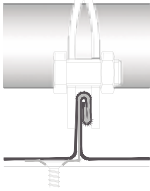

Detail of clamp on standing seam

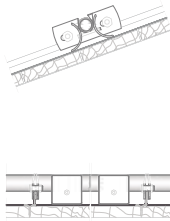

Single pipe system with ice breaker

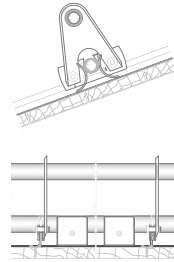

Double pipe system with ice breaker

To reduce the amount of loading on individual runs, the roof is broken up into horizontal bands across the roof by the snow retention pipes. The higher the loading, the narrower the bands need to be.



Points to bear in mind.

- The clamps should be installed on every standing seam so that the forces generated by the snow loads are evenly distributed. Follow the manufacturer's instructions regarding installation and dimensioning of the snow retention system. Important - do not overtighten the clamps - use a dynamometric wrench to tighten the nuts to the correct torque. This is to allow the clamps and pipes to break free from the roof under extreme loading, saving the roof from being torn from the substrate.
- Enough clips should be fixed along the standing seams either side of where the clamps are to be placed to ensure that the loads are transmitted to the substrate without loosening the clips. The clamps should never be placed directly over a sliding clip, as the clamping action can press the zinc trays against the base part of the clip, preventing free thermal movement of the trays. To be safe, leave a small gap either side of the sliding clips for the placement of the clamps.
- Clip distribution. Even without retention systems, when snow settles on a roof, a strong bond is formed between the snow and the metal sheets. The extra loading due to the snow exerts a dragging effect on the zinc trays, tugging them down the slope of the roof, which can only be resisted by the band of fixed clips installed across the roof (as the sliding clips are free to move in this direction). As seen above, snow retaining systems clamp to the seams and so the dragging effect on the zinc is the same.

Therefore, with or without retention systems:

- The zinc trays should have the fixed band of clips located at the very top of the roof, to avoid bucking of the trays under the additional load of the snow pulling them down. This limits the maximum length of the trays to 8mts without using specially designed sliding clips.

- Consider whether the number of fixed clips in the band should be increased in snowy climates to ensure that the trays are effectively retained. Seek further advice from your local distributor, or direct from elZinc® if required.

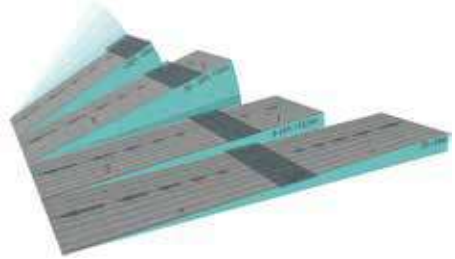

The above advice is given so designers and installers are aware of some of the issues surrounding zinc roofs in snowy regions. We recommend following regional and local regulations regarding design and installation, and seeking the advice of specialist installers with successful experience in the region.

Hot climates

In southern Europe and continental climate regions zinc roofs regularly reach 80 to 90°C in the summer, without causing any problems whatsoever for the material. In fact, it is the high-temperature performance of other components in the roof build up that designers and installers have to be wary of, so careful selection of underlays can be important in climates with hot summers.

Of course, in tropical regions the building envelop may need to be designed differently to take into account the very different conditions of temperature and humidity – consult your local distributor or elZinc® direct for more information.

Ventilated roof and wall build-ups contribute to keep the inside of buildings cool by providing an air layer over the insulation which helps protect it from the heated metal covering.

The use of reflective roof coverings can also help to reduce climate control loads in hot weather, as well as contributing to keeping cities cooler in hot weather. elZinc® has SRI data for all their products, and elZinc® Natural and elZinc Rainbow® Gold contribute towards obtaining credits in the LEED certification process in the Sustainable Sites - Heat Islands section.

Design considerations in hot climates

- Consider using a ventilated roofing or cladding design to help keep the inside of the building cool.
- In tropical regions, check with your local distributor for the most suitable build-up design.
- Ensure underlays and membranes are able to withstand the anticipated high temperatures of the zinc exterior cladding.



13

OIL CANNING, TOOL MARKS, RESHAPING DAMAGED PANELS



Oil canning on elZinc® roofing and cladding.

Traditional metal cladding using interlocked or seamed joints has been used in Europe for centuries to provide the weathering skin for buildings. It has many features which still make it the preferred choice for the majority of zinc cladding installed here. However, one of its more 'controversial' characteristics is the oil canning that can be present under certain lighting conditions, especially on steeply pitched roofing and façade cladding. This characteristic, which is inherent in these traditional systems, is well understood and accepted by architects (some notable architects love the quilted look), and installers familiar with these systems, and is not considered grounds for rejection of the work (unless of course it is very much exaggerated).

Images of various projects in different metals taken from the internet show the oil canning effect that is so characteristic of these systems.



Double lock standing seam in copper



Flat lock cladding in bronze



Housing development. Standing seam in zinc.

However, those not so familiar with these systems nonetheless may be struck by the visual effects that the oil canning can have, especially on façades. Although these visual effects will reduce over time, it is wise that everyone involved in the project be advised beforehand regarding this characteristic of fully supported metal cladding, and of measures that can be taken to reduce this to a minimum if required.

Possible field causes of oil canning.

- Poorly adjusted profiling machines. This can cause wrinkling of the panel as it is formed – normally this is eliminated by a quick adjustment of the profiler. Correct adjustment of the profiler should be set at the beginning of prefabrication and on long jobs checked periodically.
- Installation over substrates that are not in flat (accepted tolerance is +/-2mm), especially when cladding using long trays or panels.
- Over-driving of fasteners (that fix the clips back to the substrate) will pull the cladding back further towards it locally and cause buckling. In some cases the position of the clips is visible through the zinc due to this. The cladding should be fixed such that it 'floats' on the substrate rather than being fixed hard against it.
- Use of clips of incorrect height when using a structural underlay.
- Inability of the cladding to expand and contract freely in response to temperature changes, both transversally and longitudinally. The key word here is 'freely' – any resistance to thermal movement can manifest itself as oil canning. This can be

caused by use of overlong panels, sliding clips whose slider is not correctly positioned during seaming, excessive friction between the support and the metal (caused by overdriving fastener for example) or incorrectly positioned fixed clips. This type of oil canning comes and goes as the temperature of the metal cladding varies. This is also the most dangerous type, as the cyclical stresses can work-harden the material leading to eventual cracking. Proper location of the anchor point of the trays where fixed clips are used, to limit the compressive forces within the zinc as it expands is also important.

- Incorrect handling of the trays during installation. Picking up trays from one corner (which cause them to twist) and carrying them 'face up' can cause permanent distortion of the panel and oil canning – see section 07 for more information on correct handling and processing of zinc.
- Excessive foot traffic (over roofing sheets).
- Attempting to correct mal-aligned trays by 'pushing' or 'pulling' a series of trays during installation.
- Hand folding (using narrow-bladed seaming pliers as opposed to hand operated folding machines) of folds can cause oil canning if the operative does not form the fold in a gradual, 'little by little' folding process.

Oil canning is most visible:

- On façades or steeply pitched roofs.
- From a distance on façades, where one side of a 'wave' reflects light from the darker ground and the other side from the lighter sky. On approaching the façade the same wave is unable to reflect to us light from the ground, so the oil canning effect is diminished or disappears altogether.
- When the sun is shining at a shallow angle with respect to the cladding.
- When the observer is at a shallow angle to the cladding.
- On shiny surfaces that magnify oil canning (but in the case of bright rolled zinc as natural weathering develops this effect is reduced considerably).

It can be reduced at the design stage by:

- Specifying thicker gauge material up to 0,8mm.
- Reducing the bay width to 430mm (or narrower).
- In angle seam cladding, specifying folded trays instead of profiled trays.
- Specifying the use of factory cut sheets instead of coils

Once present in the cladding it is impossible to take actions to remove it and the best course of action is to let it diminish over time, but careful planning, fabrication, storage, transport and installation can reduce its visual impact if minimal oil canning is desired.

Conclusions

In conclusion, oil canning is an aesthetic issue that does not affect the functionality nor the longevity of metal cladding (unless it is a symptom of restricted thermal expansion and contraction). Its causes are varied and so if excessive oil canning is detected on a job then each step in the fabrication and installation process should be observed to pinpoint where the waviness is being generated.

Tool marks

Traditional hard metal roofing and cladding is installed on the building using a variety of hand operated tools (and on occasion electrically powered seaming machines). These tools, together with the skill, knowledge and experience of the craftsman, are used to 'dress' the metal over the substrate, creating a tailor-made metal cladding for the building.

The metals themselves must be malleable enough to allow for hand folding, bending, seaming, crimping, edging, and dog-earring.

Inevitably during the installation process, and with all due care and attention on the craftsman's part, some tool marks will be left behind as testimony to the installation process itself. The metal is 'worked' on site, and it is normal that this is evident when observing the finished cladding in any detail.

Naturally, we are not talking here about a job covered with unsightly dents and creases, or a job in which the folds have clearly been executed with no care. Work of this type should not be accepted. But cladding that in places bears the gentle marks of the craftsman's tools is most definitely synonymous with all hand worked, traditional hard metal roofing and cladding systems.

Reshaping buckled or kinked panels

If a tray or panel becomes buckled or kinked during fabrication, handling or installation, it can normally be re-shaped. Re-shaping should be carried out according to the following guidelines:

Area in which affected panel is to be installed	Key design features	Directly visible	Partially hidden
Roof	Acceptable if reshaped carefully	Acceptable if reshaped carefully	No functional impairment
Dormer cheeks	Acceptable if reshaped carefully	Acceptable if reshaped carefully	OK if reshaped
Verge, fascia	Tolerable if carefully reshaped	Acceptable if reshaped carefully	OK if reshaped
Gable	Critical	Tolerable if carefully reshaped	OK if reshaped
Façade	Critical	Tolerable if carefully reshaped	Acceptable if reshaped carefully





14

**elZinc & FIRE
SAFETY**

elZinc and fire safety

Reaction to fire.

Zinc sheet is a non-combustible metal. As such it is included in a list of materials that do not require fire reaction testing in the EU. This is by virtue of the European COMMISSION DECISION of 4 October 1996 (96/603/CE), which established a list of products belonging to Class A1 'No contribution to fire' which are not required to have undergone reaction-to fire testing. Additionally, metals finished with an inorganic coating can also be considered class A1.

Thus, according to the above, the following products can be considered Class 'A1' 'No contribution to fire'.

elZinc® Natural	elZinc Lava®
elZinc Slate®	elZinc Oliva®
elZinc Graphite®	elZinc Crystal®

However, European Euroclass codes (section 1.2.2) do require metal sheet and coil to be tested if an organic surface finish represents more than 1% of either the weight or volume of the product, whichever is the more onerous. This is the case of elZinc Rainbow®, elZinc Protect+®, elZinc Rainbow Protect+. elZinc has therefore tested these product's reaction to fire, and the results are as follows:

- elZinc Rainbow®: A2-s1,d0 according to EN 13501-1:2007+A1:2010: Fire classification of construction products and building elements – Part 1: Classification using test data from reaction to fire tests.
- elZinc Rainbow® Protect+: A2-s1,d0 according to EN 13501-1:2007+A1:2010: Fire classification of construction products and building elements – Part 1: Classification using test data from reaction to fire tests.

Notes:

- Class A2 materials are described as non-combustible and having "no significant contribution to fire growth".
- -sX classifies the amount of smoke generated, on a scale from s1 (least amount of smoke) to s3 (greatest amount of smoke).
- ,dX classifies the amount of flaming droplets generated, on a scale from d=0 (no flaming droplets) to d2 (greatest amount of flaming droplets).

Fire performance of elZinc finishes

This classifies materials according to their performance during external fire exposure. As with reaction to fire classification, by virtue of the European COMMISSION DECISION of 6th September 2000 (2000/553/CE) the European standard provides a list of materials (table 2.2-1) that are classified B_{roof}(t1/t2/t3) without the need for testing. Zinc sheet, profiled or flat, is included in the list, as long as:

- The surface finishes, if there are any, are inorganic.
- Organic surfaces should they exist, have a PCS $\leq 4,0$ MJ/m² or a combined mass of ≤ 200 g/m².

Therefore, according to the above, the following products can be considered Class B_{roof}(t1/t2/t3):

elZinc® Natural	elZinc Crystal®
elZinc Slate®	elZinc Advance®
elZinc Graphite®	elZinc Advance® Protect+
elZinc Lava®	elZinc Rainbow®
elZinc Oliva®	elZinc Rainbow® Protect+

Nevertheless, test results for Rainbow Protect+ for its fire performance are available.

- elZinc Rainbow® Protect+: Class B_{roof}(t1) according to EN13501-1:2007+A1:2010: Fire classification of construction products and building elements - Part 5: Classification using data from external fire exposure to roofs tests.

For fire classification of elZinc products fabricated in conjunction with other materials, please see the relevant product literature. All elZinc finishes are class A2 or better, according to the table below:

Fire Classification	EN13501-1:2007+A1:2010: Fire classification of construction products and building elements	
elZinc product	Part 1: Classification using test data from reaction to fire tests.	Part 5: Classification using data from external fire exposure to roofs tests.
elZinc® Natural	A1	B _{roof} (t1/t2/t3)
elZinc Slate®	A1	B _{roof} (t1/t2/t3)
elZinc Graphite®	A1	B _{roof} (t1/t2/t3)
elZinc Lava®	A1	B _{roof} (t1/t2/t3)
elZinc Oliva®	A1	B _{roof} (t1/t2/t3)
elZinc Crystal®	A1	B _{roof} (t1/t2/t3)
elZinc Rainbow®	A1	B _{roof} (t1/t2/t3)
elZinc Rainbow® Protect+	A1	B _{roof} (t1/t2/t3)
elZinc® Advance	A1	B _{roof} (t1/t2/t3)
elZinc® Advance Protect+	A1	B _{roof} (t1/t2/t3)

Roof and wall build-ups

In the EU, buildings over a certain height (often 18mts) must only use non-combustible materials in their roofs and façades, so in addition to using an external cladding such as elZinc to comply with this regulation, the rest of the envelope's construction must also be non-combustible.

In such cases, metal trapezoidal decking substitutes the wooden boarding or sheathing for the zinc's substrate.

elZinc® Square tile

The elZinc® Square tile is supplied with a polystyrene backing that provides impact resistance at low levels in façades and allows some foot traffic on roofing applications. This backing clearly negatively affects the fire rating of the tile, and tiles supplied with the backing cannot be considered non-combustible. The fire rating of the polystyrene is class E.

The tile can be supplied without the backing for buildings which require an A1 or A2 fire rated cladding material.



FLEET & LOGISTICS

15800



A vertical strip on the left side of the page shows a nighttime cityscape with illuminated buildings and streetlights against a dark sky.

15

**elZinc ROOFING
& LIGHTNING
PROTECTION**

Zinc roofs and lightning protection.

Metal roofs do not attract lightning strikes. The probability of lightning striking a particular building depends on its location, height and the ground area it covers, and not on the materials it is built out of. However, due to their good electrical conductivity they can help protect the building from the consequences of a strike. Local and national regulations should be followed always. Below is some advice regarding lightning protection installed on elZinc® roofs.

elZinc® Natural, elZinc Alkimi®.

The surfaces of these materials conduct electricity and therefore the whole roof can be used as a '2D lightning conductor'. This is because the standing seam roof system connects the trays together with sufficient contact area to connect the entire roof 'electrically'. This is even true of low-pitched roofs which have a sealing strip inserted into the seam for weatherability purposes.

Typical detail at ridge:

The ridge capping is connected to a conductor rod that is in turn connected to a clamp, tightly fixed to the standing seam. The clamp does not penetrate the zinc roof covering.

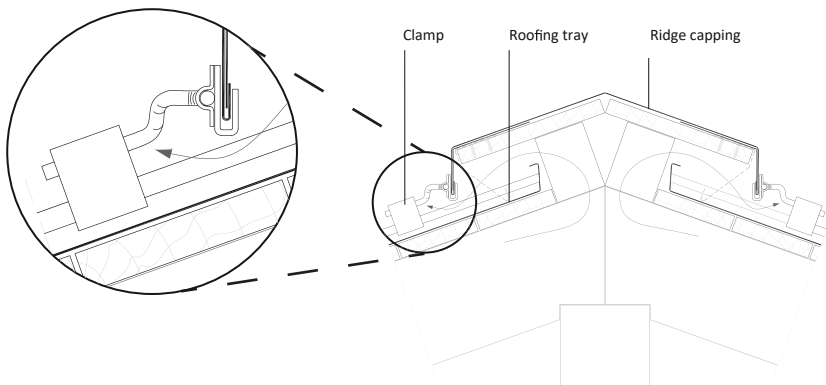

Typical detail at eaves:

A clamp is tightly fixed to the end of the standing seam, and a conductor rod is attached to it. The rod is taken around the eaves detail and down to the ground where it is earthed.

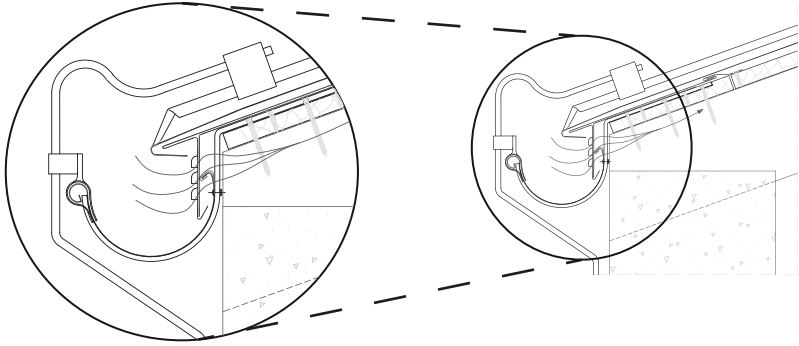
**Notes:**

- The clamps, rods and other lightning protection elements must be installed by a specialist. All materials employed must be compatible with the elZinc product.
- If required, provision should be made for the thermal expansion and contraction of the zinc standing seam trays. This can be achieved by using flexible conductor rods / connectors.
- All components of the zinc roofing must be connected electrically. So vented ridges, flue caps, chimneys, and any other flashing not seamed into the roofing trays must be connected by a conductor.
- In areas likely to receive heavy snow falls, provision of protection of the clamps and conductors from snow slippage by providing adequate snow retention should be considered.
- If possible, lightning conductor cables can be concealed behind rainwater pipes to keep the façade tidy

elZinc Rainbow®, elZinc Advance®, elZinc Protect+®

These finishes are not electrically conductive, and so conductors have to be laid over the roof surface and taken down the walls. These can be secured using appropriate tabs held in place by adhesive tape. We approve GPH 160 3M tape used in conjunction with its AP111 primer. Please contact elZinc® before using a different make of adhesive tape.

Notes:

- In areas likely to receive heavy snow falls, provision of protection of the tapes and their holding tabs from snow slippage by providing adequate snow retention should be considered.





16

GOOD PRACTICE ON THE BUILDING SIDE

Before installation

Please refer to the section on the correct storage of elZinc® on the building site.

If the cladding substrate and build up is prepared by others, it is recommended that the zinc installer check the work before commencing zinc installation:

Check the condition of the substrate

- Wooden sheathing or boarding should be dry to the touch - its moisture content should not be above 18%.
- Surface of the substrate should not be too rough, porous, damp, dirty or oily.
- Correct fitting of eaves board to allow for fixing of roof attached gutter brackets independently of the rafters.
- Soft wood boarding should be free from wane, cupping and unevenness. Sheathing should not present raised joints due to insufficient gaps between boards. All fasteners should be driven to just below the surface.

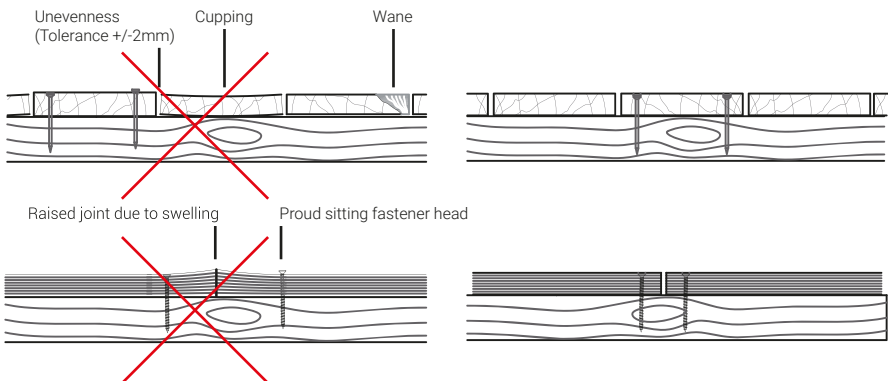

- Be swept free of grit and debris.
- Check the specified thickness against that of the actual boarding or sheathing (or metal sheeting).
- Regarding the fixing of the substrate, check for missing nails or fasteners. Check for protruding nail or screw heads.
- Sufficient fixing surfaces at corners, joints, recesses or penetrations.

Geometry of the substrate

- Correct pitch / fall.
- That the zinc will be able to expand and contract correctly, and the trays will not be over-long.
- Smoothness of curves in the substrate (on vaulted roofs for example). The zinc will follow the line of the substrate so any irregularities in the curvature will be visible in the zinc's surface.
- Check for missing crickets (saddles) behind wider chimneys / roof lights etc.
- Sufficient depth to accommodate recessed valley gutters.
- Parapet gutters and internal gutters have correct falls, and correct outlets to downs pouts. Check for overflows if required.

Envelope build up

- Correct dimension of ventilation layer, and that it is uninterrupted.
- Correct positioning and installation of the vapour barrier in warm roofs is essential, as is the use of an appropriate type of vapour barrier material.

Scaffolding, platforms

- A discussion between the builder and the installer is useful to determine the best means of access. Scaffolding ties can be uncomfortable to work around, and mean skipping panels for after tie removal. Installation of these panels can be cumbersome.
- Platforms (cherry pickers). Check range and max load (to allow for a good number of pieces to be taken up at any one time).

For your information this is treated in another document, specific to setting out

Gravel over flat roofs

Laying gravel (used over membrane roofs for example) can generate considerable amounts of dust which will settle on surrounding materials. This can lead to staining on zinc surfaces, so any zincwork nearby should be left until the gravel is in place.

During installation

The following is offered as guidance during installation.

- **If possible, aim to complete areas installed in a day.** Close seams, finish flashings, make the area weathertight.
- **Take back to storage any panels not installed** (or protect and secure them if left outside on the roof). Make sure any protection does not trap moisture on the zinc's surface (which could lead to staining).
- **Longer interruptions in work require more permanent protection**, able to withstand the foreseeable weather over the period.
- **Keep the roof clean** of fasteners, wood chips and splinters, adhesive strips and general debris.

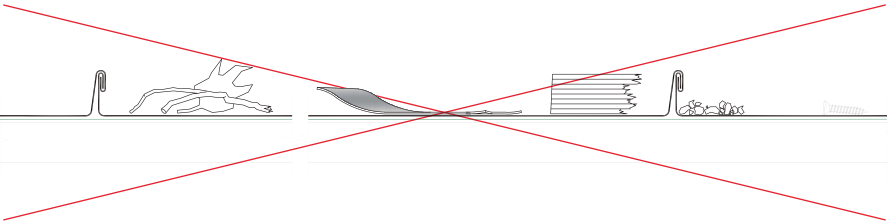

Wood chips and splinters absorb moisture, and can stay humid for enough time to mark the bright zinc surface. Care should also be taken with elZinc Alkimi®, Rainbow and Advance.



Adhesive strips should be removed from the zinc Surface as soon as detected, and any adhesive residue cleaned.

- **As far as possible other trades that generate dust must be scheduled to complete before the zinc work starts.** If not possible, the protective film should be left on (up to the limits given below). If required, provision for additional protection should be made.
- **Concrete and mortar spills should be cleaned as soon as they are detected** – see cleaning guidelines.

- **Anything left standing on the zinc in damp weather** (boxes of clips, tool boxes etc.) should be put on a base laying over the standing seams and not in the pan of the tray.

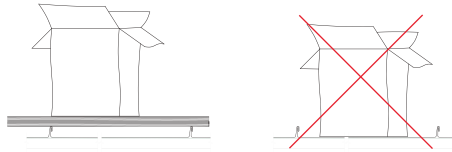

- **Do not store pallets or in general any timber on roofs.**
- **Fingerprints.** elZinc Natural will show fingerprints, especially in warm weather when hands are perspiring. These marks can be unattractive, and until the surrounding zinc weathers in, will be clearly visible. elZinc Alkimi has an anti-finger layer, but repeated handling in the same spot will rub it away (it is designed to naturally weather away over time). If finger marks are unacceptable, then gloves should be worn.
- **Plastic protective film removal.** Correct behaviour of the film on removal cannot be guaranteed beyond 8 months after dispatch from elZinc, and the film should be immediately removed after installation.

Over these limits the film can become brittle and be very time consuming to remove. For more information on the protective film, see section 04 - Product data.

Partial removal of film (which is necessary on flat lock shingles for example) can cause temporary differential weathering between the protected and unprotected surfaces, especially on elZinc® Natural and to a lesser extent elZinc Alkimi®. After a time, these differences disappear. For correct partial removal of film, follow the instructions on page 26.

Caution, the film is slippery when wet, exercise due care when walking on damp roofs.

- **Foot traffic.** Zinc roofs are able to withstand all foot traffic associated with installation. Repeated walking over the same area can affect the appearance of the trays, especially if the footwear is dirty. Boots covered in building dust, (cement, lime dust) can lead to staining of the zinc surface as previously described. Leaving the protective film on the material during this time (without exceeding the limits described beforehand) can prevent this. In general, 'routes' should be established to avoid installers walking all over the roof to access the same part of it during installation.



After installation and until completion of building works.

Please refer to the section on cleaning and maintenance for advice on keeping the zinc cladding in good repair during the remainder of the building works.

- **If dust is still being generated by other trades, zinc should be protected to avoid staining.** The protective film can be left on (up to the limits given above). If necessary, use tarpaulins or similar, but remember any moisture trapped between them and the zinc can cause white rust to form on bright zinc surfaces, and possibly even on eZinc Alkimi® products, so any moisture must be free to dry off.



Staining caused by cement and plaster dust is costly to remove if it has stained the surface after light rain, fog or dew.

- **Cleaning of other materials close to zinc.** Overspray from cleaning brickwork and masonry (brick acids) can lead to significant staining of nearby zinc work. Be very careful undertaking such operations around finished zinc – these operations should be scheduled before zinc work commences if possible.



Staining caused by cleaning of adjacent brickwork by baking soda. These stains are difficult or impossible to remove without damaging the pre-weathered surface of Alkimi products, due to the chemical bonding of the contaminant to the surface. Depending on the aggressiveness of the cleaning products, also Rainbow and Advance finishes can be affected







17

PROJECT DOCUMENTATION AND PRE-START INFORMATION

Project documentation and pre-start information.

Correct specification of the zinc cladding together with drawings of the zinc package are key to successfully designing and executing zinc roofing and cladding. They must give a comprehensive description of the work to be undertaken.

elZinc® is ready to assist the designer in the elaboration of the documentation, and through our distributor network can provide standard 2D and 3D drawings, rendered detail images, BIM objects, written specifications and personalized detail development, as well as mock-ups and general material samples.

For their part, the installer must examine the information carefully and bring their professional experience to bear.

According to the requirements of individual projects, the following points in particular are to be indicated in the project documentation:

- General information regarding the building site
- If relevant (e.g. because of the seam direction), prevailing wind direction.
- Complementary regulations, if any, which supplement the National Codes of Practice of the trade.
- If applicable, type and number of required samples or full-scale mock-ups.
- Roof and cladding geometry and features
- Roof pitch on all areas.
- Curved areas, dormer windows, special geometrical or ornamental features.
- Quantity, type and design of roof penetrations, skylights and domed roof lights.
- Quantity of chimneys, and whether / how they are to be clad.
- Type and design of fall arrest systems, snow guards, and lightning protection.
- Type, design and location of walkways and PV panels, paying particular attention to clip requirements in the standing seams of the zinc to resist the extra loading.

Design intent and the extent and appearance of the roofing and cladding.

Note – not everything can be included in the project documentation. Where critical features are concerned it is recommended that a dialogue be established between all parties to ensure a solution is found which is in line with the design intent.

- Specified roofing and cladding system.
- Seam layout design drawing, and position of windows, doors and other openings w.r.t. the seam layout.
- Drawings of typical details
 - Roofs - eaves, ridge, hips, valleys, gables, fascias, internal gutters, abutments etc..
 - Façade – foot detail, wall capping, internal and external corners, window surrounds etc.
- Requirement of detail drawings by the installer.
- elZinc product
- Specified elZinc® finish or finishes, (both aesthetic and technical).
- Specified thickness or thicknesses.
- elZinc Protect+® underside protection coating if required.
- Design of the substructure
- Specification and description of materials making up the envelop, and how they should be installed.
 - Underlay (including structural mat if required)
 - Substrate, including any wood preservatives, if applicable.
 - Details of the ventilation gap in vented roofs and façades, along with air inlet and outlet requirements.
 - Thermal insulation
 - Timber battens or metal profiles
 - Wind, vapour control layer and vapour barrier.



- Reaction to fire requirements
- Provision for recessed valley gutters if required.
- Rainwater drainage provisions
- Type and location of outlets, gutter girths, quantity, type and size of gutter brackets, dimension and shape of rainwater pipes, eaves flashing and other rain water accessories and their thicknesses.
- Gutter falls if applicable.
- Overflow designs and locations if applicable.
- Location and type of expansion joints.
- Measures for storm protection during installation
- Requirements due to Installation procedures
- If applicable, permissible loads of the roof areas or load-bearing structures, to determine limits of storage of materials during installation, or limits of coil weights and machinery weights if profiling on the roof.
- Scaffolding type or other means of elevation (cherry pickers).
- Building site requirements for fire prevention, sound and heat insulation and fire protection.
- Availability of secure and suitable storage for zinc coils or prefabricated trays and flashings
- Description of provisional protective coverings for completed zinc work.
- Health and safety at work requirements.

If ambiguities are detected in the project documentation or if contradictions arise while the work is being carried out, these should be raised by the installer.

The raising of concerns is provided for in the various regulations and is not to be seen as “unfriendly”. The discussion between the planner and the contractor, that is attuning the design and the implementation which has been professionally thought through, leads to constructive collaboration and good results.





In addition to the more than 500 Architectural Details available in pdf and autocad for facades and roofs in zinc available to you from eZinc.es, now you can check out our 3D Models.





18

**PRESENTING THE
MOST USUAL
SYSTEMS**

The systems

Traditional systems

Traditional roofing and cladding systems have become essential for designers. They enhance both old buildings and contemporary architecture.

Thanks to their multitude of variants and the range of surface aspects offered by elZinc®, these systems offer you extraordinary creative freedom.

Technical systems

The technical systems are composed of self-supporting panels that are fixed on a wooden or metal frame.

These relatively new techniques offer you new design possibilities. They are an alternative to traditional techniques and bring a new aesthetic to your project.

Double lock standing seam

- Proven, versatile system for roofing flat, curved and 'free-form' roofs.
- Weather-tight down to 7° of pitch, 3° if seams are sealed.
- Items such as snow guards and life line attachments are readily available.
- Modern profiling and seaming machines facilitate short installation times.
- On-the-roof detailing uses folding techniques or soldered joints – no mastic!
- Discrete joints give a light, elegant appearance.

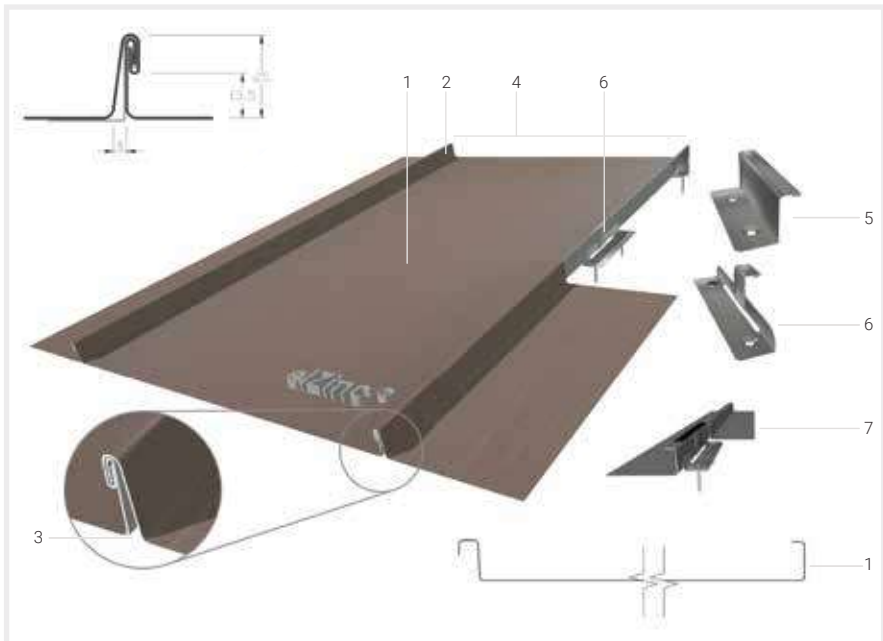

1. eZinc® Standing seam roofing tray, nominal max. length 10m

2. Standing seam joint (normally follow line of maximum pitch)

3. Expansion gap at seam base

4. Seam centres dimension. Normally from 430 to 600mm

5. Stainless steel 'fixed' clip – anchors the tray in position

6. Stainless steel 'sliding' clip - allows longitudinal expansion

7. Self-expanding sealing strip for roofs pitched under 7°

Angle standing seam

- Traditional cladding system based on the double lock standing seam
- Principally used in façade cladding, on flat or curved areas.
- Can use semi continuous substrate
- Attractive design layouts complement different architectural styles
- Suitable for ventilated façade designs
- Weather-tight from 25° of pitch and above if used in roofing. 35° in regions with heavy snowfall

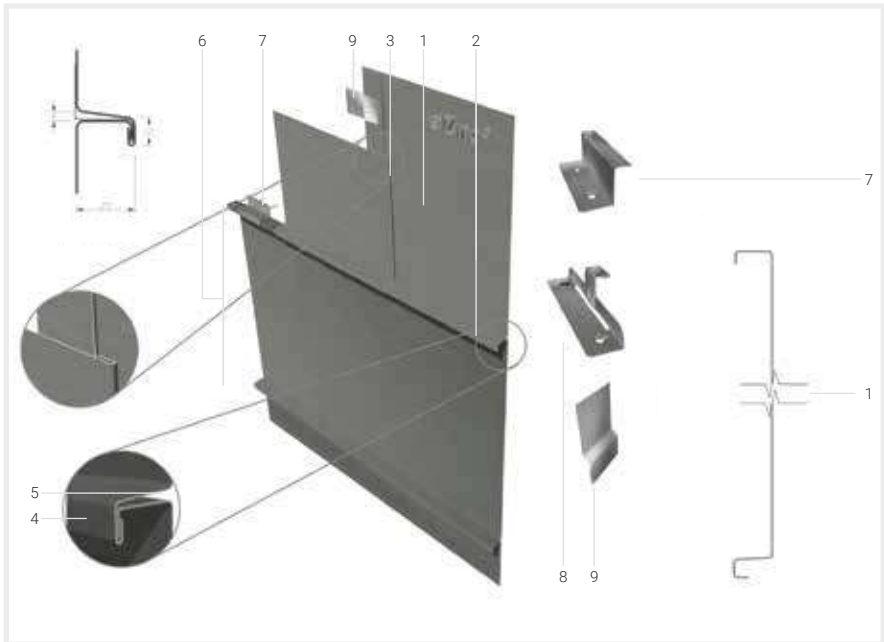

1. eZinc® angle standing seam roofing tray.

2. Angle Standing seam joint (horizontal, vertical or set at an angle).

3. Flat lock transversal joint.

4. Welt of angle seam.

5. Expansion gap at seam base.

6. Seam centres dimension, normally from 430 to 600mm.

7. Stainless steel 'fixed' clip – anchors the tray in position.

8. Stainless steel 'sliding' clip

9. Stainless steel flat lock clip

Flat lock shingles

- Traditional cladding system using interlocking panels
- Principally used in façade cladding (on flat or curved areas), mansard roofs, and domes.
- Weather-tight from 25° of pitch and above if used in roofing
- Attractive design layouts.
- Suitable for ventilated façade designs
- Can use semi continuous substrate

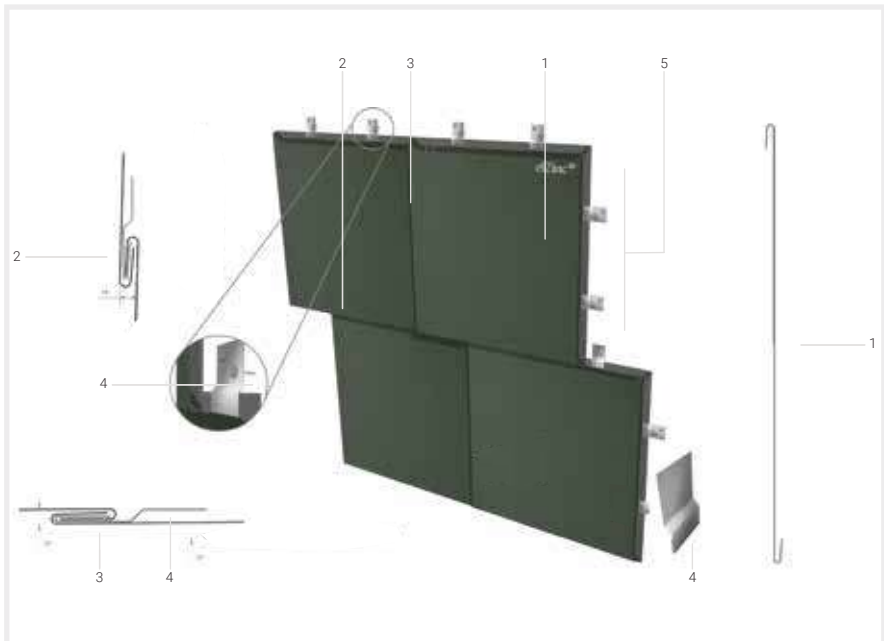

1. eZinc® flat lock shingle tray.
2. Flat lock dominant joint.
3. Flat lock transversal joint.

4. Stainless steel clip (can also be made of the same zinc as the cladding).
5. Seam centres dimension, normally 430 to 600mm.

Batten roll

- A traditional, more structured appearance than the standing seam
- Can be used in combination with standing seam to 'modulate' roofs and facades.
- Resistant to heavy foot traffic
- Weathertight down to 3° without sealing
- Alternative variations exist (Traditional French, Belgium).

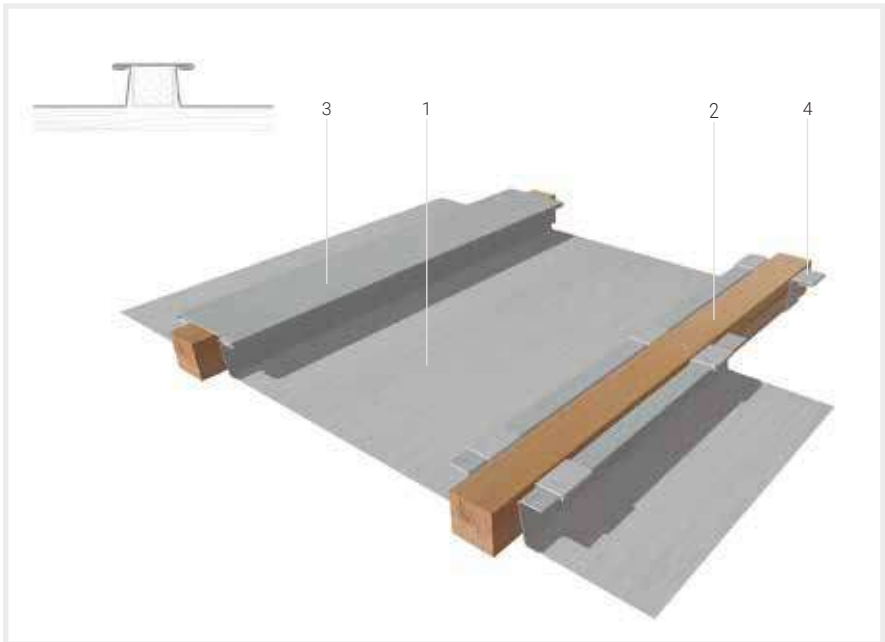

1. Roofing tray
2. Softwood batten

3. Batten capping
4. Roofing tray clip

elZinc tiles

Made of elZinc® zinc-titanium (EN988 standard), they lend themselves to many styles of architecture, harmonising perfectly with the surrounding materials.

Whether for new-build or refurbishment projects, the elZinc range of five distinct tile designs are a great solution for wall cladding and for weathering roofs pitched over either 25° or 45°, depending on the designs chosen.

In addition to their ecological and aesthetic:

- Easy to install
- Suitable for most projects
- Highly corrosion resistant.
- Virtually maintenance free.

Square tile

elZinc's square tile with polystyrene backing is notable for its ease of installation. Its clean design gives the cladding an elegantly neat appearance.



Rhomboid tile

The elZinc® rhomboid tile gives a stylised look to roofs and façades. The sleek interlocking tile highlights verticality, and is suited to both modern and traditional architecture.



Pointed fish scale tile

This elZinc® tile brings to mind images of baroque architecture. It provides, in its simplicity, a discreet, traditional feel to the building.



Rounded fish scale tile

A new twist on a classic model. elZinc's® rounded fish scale tile is inspired by a shape commonly used in classical European architecture.



Diamond tile

The diamond tile elZinc® offers the architect a modern and attractive option. A larger format tile suitable for a wide range of applications.



Façade panel

- Single skin self-supporting panels with tongue and groove joint
- Narrow aspect ratio – length up to a nominal 4m, width up to 300mm
- Suitable for flat or gently curved façades and soffits
- Panels are normally installed in either a horizontal or vertical direction
- Uses 1mm thick elZinc®
- Direct fixing using screws or rivets to metal rail substructure

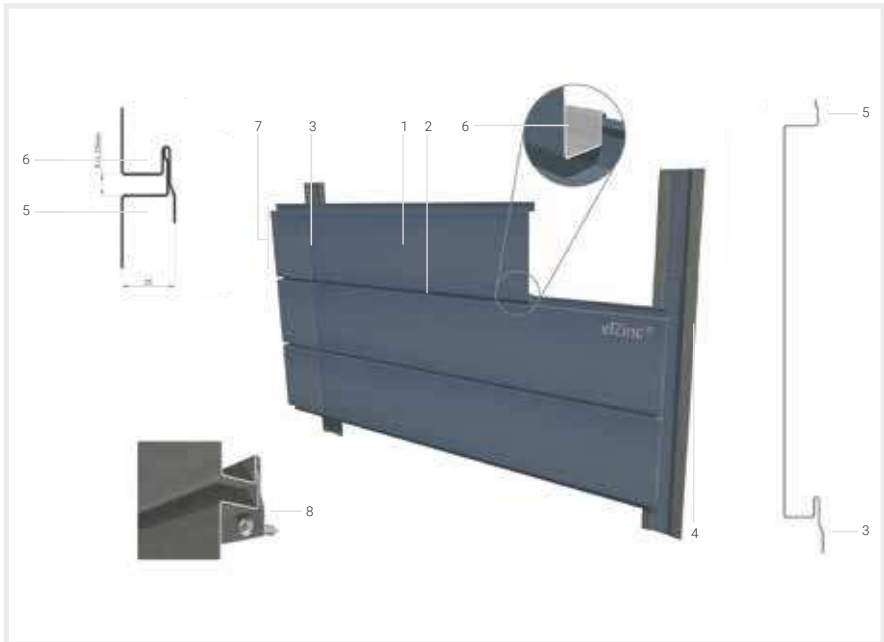

1. elZinc® profiled Façade panel. Maximum length nominally 4m.
2. Tongue and groove joint, can be varied from 5 to 25mm wide.
3. Transversal shadow joint.
4. Vertical weathering strip.

5. Tongue profile. Adjusts in length to vary joint width.
6. Groove profile
7. Joint centres dimension.

8. Direct fixing using self-drilling screws or rivets to rail profile sub structure (not shown).

elZinc® composite material

- elZinc® faced composite material
- Various fixing options and sub structure types available
- Large panel sizes possible (1000mm x 8000mm max.) depending on installation system
- PE, FR (B-s1,d0) and A2 (A2-s1, d0) cores available.
- Can be curved
- Excellent flatness and rigidity

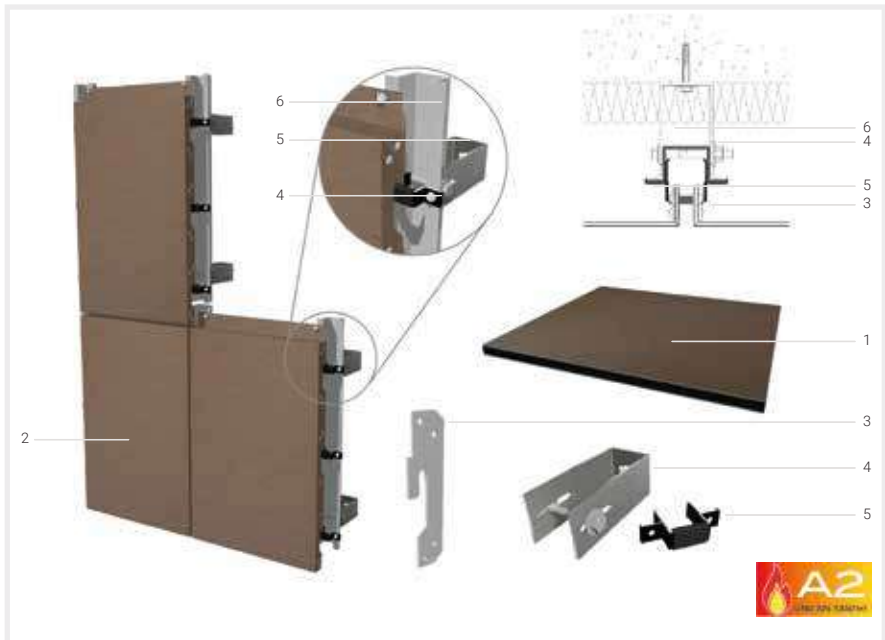

1. elZinc® composite material
2. elZinc® composite panel
3. Flange reinforcement

4. Adjustable wall bracket
5. Panel support with anti-vibration sleeve
6. Top hat profile

elZinc® honeycomb panel

- elZinc® faced aluminium honeycomb panel
- Perfect flatness
- Extremely rigid, very large panel sizes possible
- A2 fire rating (A2-s1, d0)
- Bespoke, point fixing system reduces sub structure costs
- Quick and easy precision installation
- 100% recyclable
- Wrap around edges for added safety

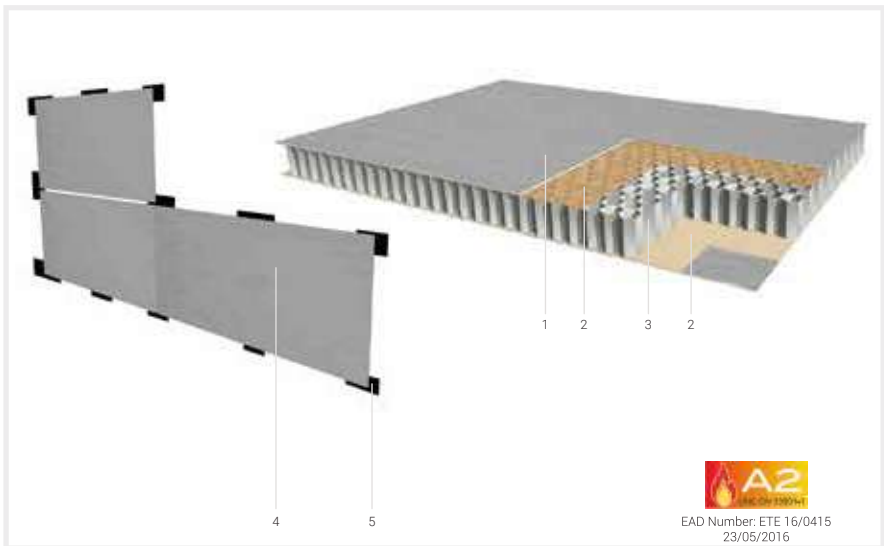

1. 0.5mm elZinc® panel skin

2. Adhesive

3. 14mm aluminium honeycomb core

4. elZinc® honeycomb panel

5. Point fixing system

Rainwater systems

- Tried and tested systems used for generations.
- Attractive designs in half round, box section and cornice styles.
- Very long lasting and maintenance free.
- Does not deteriorate due to UV radiation.
- Fully recyclable.

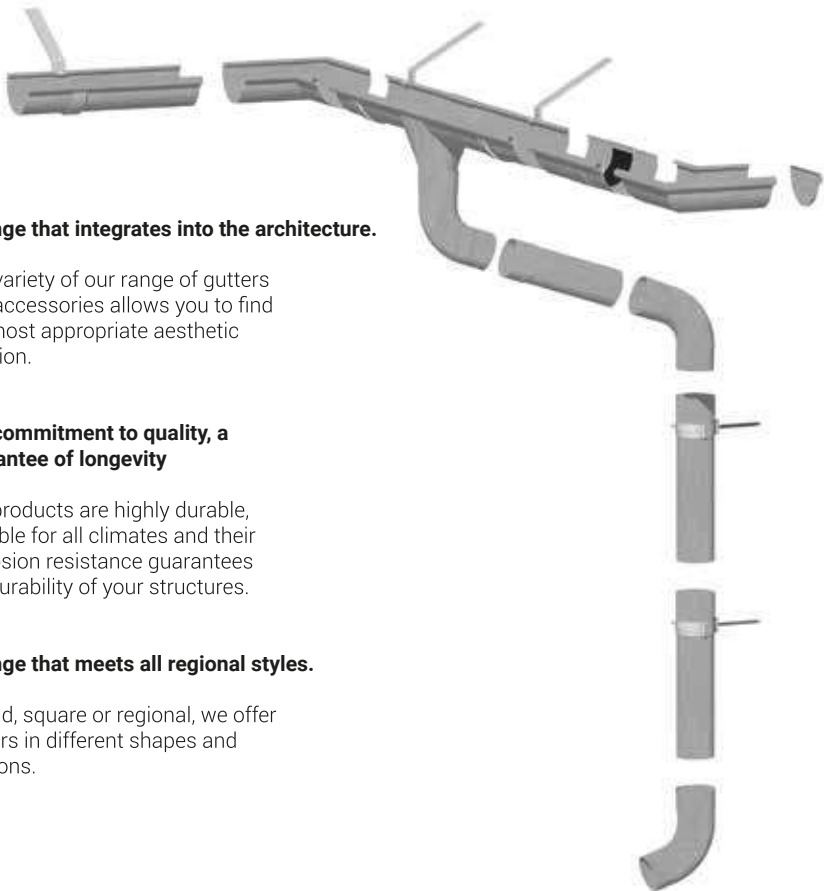

A range that integrates into the architecture.

The variety of our range of gutters and accessories allows you to find the most appropriate aesthetic solution.

Our commitment to quality, a guarantee of longevity

Our products are highly durable, suitable for all climates and their corrosion resistance guarantees the durability of your structures.

A range that meets all regional styles.

Round, square or regional, we offer gutters in different shapes and sections.





19

DISCLAIMER

Asturiana de Laminados, S.A. has developed instructions and recommendations – published on this website and on other printed documents – with the aim of providing a better service for its customers. It is generic information for standard installation of elZinc® products in a European climate.

This information must not substitute the considerations and requirements that, in each project, architects, designers and consultants may offer.

Asturiana de Laminados, S.A. does not accept any responsibility therefore for any damage incurred to third parties, directly or indirectly by the misapplication, misinterpretation or general incorrect use of the information contained in all its tools and documents, exonerating itself from all and any responsibly deriving from this document, within the legal framework established and applicable in each case.

We remind readers that Asturiana de Laminados, S.A. provides an advisory service to assist in the interpretation and use of this information should any doubts arise in this regards.

The Company reserves the right, at its discretion, to change or update the information included in this guide without prior notice.





20

**USEFUL
INFORMATION**

Girths from different material widths

Strip width	Number of strips						
Material Width	2	3	4	5	6	7	8
500	250	167	125	100	83	71	63
600	300	200	150	120	100	86	75
650	325	217	163	130	108	93	81
670	335	223	168	134	112	96	84
1000	500	333	250	200	167	143	125
1219	610	406	305	244	203	174	152
1250	625	417	313	250	208	179	156
1340	670	446,67	335	268	223,33	191	167,5

Weight to area conversion table, flat sheet.

Nominal thickness (mm)	kgs/m ²	kgs/ 100m ²	kgs/1000m ²	m ² /kg	m ² /t	kgs	m ² /kg	m ²	kgs
0.5	3.6	360	3600	0.278	277.8	1	0.278	1	3.6
0.65	4.68	468	4680	0.214	213.7	1	0.214	1	4.7
0.7	5.04	504	5040	0.198	198.4	1	0.198	1	5
0.8	5.76	576	5760	0.174	173.6	1	0.174	1	5.8
1	7.20	720	7200	0.139	138.9	1	0.139	1	7.2
1.2	8.64	864	8640	0.116	115.7	1	0.116	1	8.6
1.5	10.80	1080	10800	0.093	92.6	1	0.093	1	11
2	14.40	1440	14400	0.069	69.4	1	0.069	1	14
2.5	18.00	1800	18000	0.056	55.6	1	0.056	1	18
3	21.60	2160	21600	0.046	46.3	1	0.046	1	22







21

GLOSSARY

A

ASTm B-69	19, 22, 23
------------------	------------

B

Bending radii	60
Bituminous Products	78

C

CE marking	19
Cementitious materials	76
Cold weather working	53, 61
Composite panels	39, 135

D

Damaged panels	65
Delivery Programme	34, 35
Density	22, 39
Dust	26, 45, 53, 54, 55, 66, 77, 116, 117, 118

E

Electrical conductivity	22, 110
elZinc Advance	25, 26, 32, 47, 60, 66, 68, 73, 75, 76, 77, 79, 83, 89, 105, 111
elZinc Alkimi	15, 19, 24, 25, 26, 30, 34, 39, 44, 47, 60, 61, 68, 73, 74, 110, 116, 117, 118
elZinc Composite	39, 135
elZinc Honeycomb	25, 36, 39, 136
elZinc Light	40
elZinc Protect+	32, 61, 73, 75, 76, 77, 79, 104, 111, 123
elZinc Rainbow	14, 19, 24, 25, 26, 32, 35, 39, 44, 47, 60, 61, 66, 68, 73, 75, 76, 77, 78, 79, 83, 84, 88, 89, 95, 104, 105, 111
elZinc Rainwater	38, 137
elZinc Tiles	38, 133

elZinc Warranty	19
elZinc Wide	36, 37
En 988	19, 22, 23, 27, 38, 133
EPD	15
Expanded zinc	40

F

Fibre cement	77
Film Removal	26, 117
Fingerprints	67, 117
Foot traffic	65, 100, 106, 117, 132

G

Galvanic corrosion	72, 73
Graffiti removal	65, 66

H

Honeycomb panels	39, 136
-------------------------	---------

I

Ice dams	90, 91, 92, 93
ISO 14001	15
ISO 50001	
ISO 9001	19
ISO 45001	

K

KOMO certificate	19
-------------------------	----

L

LEED	15, 24, 95
-------------	------------

M

Magnesium oxide boards	77
Melting point	22
Moisture content	114

P

Perforated zinc	40
Protective Film	25, 27, 34, 35, 52, 116, 117, 118

R

RAL	24
Reshaping	101

S

Salinity	83
Salt deposits	47, 64, 66, 83, 84
Scaffolding platforms	115
Sealants	77, 78, 79
Snow	89, 90, 91, 93, 94, 111, 122, 129
Solar Reflectance (SRI)	14, 24, 95
Soldering	22, 65, 67

T

Tapes	78, 79, 111
Thermal conductivity	22
Thermal Emittance	14, 24
Thermal expansion and contraction	39, 101, 111
Timber	74, 75, 76, 117, 123
Tool Marks	101

V

Ventilation	92, 115, 123
--------------------	--------------

W

White Rust	46, 48, 68, 118
Wood	30, 75, 76, 92, 114, 116, 123
Wood preservatives	76, 123

FACTORY AND HEAD OFFICE

ASTURIANA DE LAMINADOS, S.A.
Pol. Ind. de Villallana, Parcela 1
33695 Pola de Lena – Spain

T (0034) 98 567 60 00 / 98 410 60 00

F (0034) 98 549 32 02 / 98 569 20 00

elzinc@aslazinc.com

www.elzinc.es

