



Double lock standing seam Guide to detail forming

www.elzinc.es

elZinc

Designing with elZinc®

Index

Introduction to this guide	03
elZinc® a quality brand	03
elZinc® a long-lasting building material	03
elZinc® Finishes	04
elZinc® Alkimi	04
elZinc Rainbow®	04
Matrix standing seam	05
DLSS I 1.2.1.01a - Squared foot	06
DLSS I 1.2.1.02a - Chamfered foot	10
DLSS I 1.2.1.02b - Chamfered foot	15
DLSS I 1.2.1.03a - Curved foot	18
DLSS I 1.2.1.03b - Curved foot	24
DLSS I 1.2.1.05 - Swabian foot	28
DLSS I 1.2.1.03a - Turned down upstand	31
DLSS I 1.2.2.02a - Straight dog-eared upstand	34
DLSS I 1.2.2.02b - Preformed straight dog-eared upstand	39
DLSS I 1.2.2.03a - Pinched seam	44
DLSS I 1.2.2.03b - Saddled pinched seam	49
DLSS I 2.1.01a - Single lock cross welt	53
DLSS I 2.1.01b - Single lock cross welt	58



Introduction to this guide

Correct execution of zinc roofing and cladding work is key to the performance of the envelope. It also contributes greatly to its aesthetic appeal.

This booklet shows the forming process of some of the most commonly used details for finishing a standing seam at its foot and at its head in roofing. The process is broken down into simple steps with easy to interpret drawings, with the use of symbols and minimal text, so installers can understand the cutting and folding sequences and correctly execute the details worldwide without having to read an unfamiliar language.

elZinc recognizes that different countries, regions, and contractors have different ways of doing things, and even within the same contractor, different roofers have their own habits, so not everyone will execute the details exactly as indicated in this document. This is fine as long as the detail performs as it should and looks correct. The seam end details are numbered so that they correspond to those in the DLSS elZinc Architectural Details set, so their application in complete solutions for eaves, abutments or ridges and hips etc. can be easily referenced.

The tools required to complete each step are shown as icons in the notes section of each drawing.

This guide should be read in conjunction with all the other relevant technical and sales literature from elZinc.

For correct printing, please make sure to set your printer to a 100% scale.

elZinc® : a quality brand

The use of the best technologies available on the market allows us to offer zinc quality products that exceed the requirements of standard EN 988 and ASTM B-69 within which are established the specifications for flat-rolled products of zinc alloys for use in building.

The alloy is produced from zinc of the highest quality (Z1 >99,995%) – according to the European standard UNE-EN 1179 – to which is added precisely controlled quantities of copper (Cu) and titanium (Ti) to improve the zinc's properties. The alloy's purity is closely monitored by a series of finely regulated controls.

elZinc®: a long-lasting building material.

Zinc is a 'living' material, it protects itself by naturally developing a patina during the early stages of its life that guards against corrosion, and gives it self-healing properties making it extremely durable.

Its life span can exceed 100 years (depending on the surrounding atmosphere), indeed in wall cladding applications some experts estimate an expected life span of some 200 years. In order to guarantee the longevity of this versatile metal, correct execution of the zinc cladding is a must.

elZinc® Finishes

Full of contrasts, the elZinc range of finishes is currently the widest on the market. Divided into two range of finishes - elZinc Alkimi (elZinc Natural, elZinc Slate®, elZinc Graphite®, elZinc Crystal®, elZinc Lava® and elZinc Oliva®) and elZinc Rainbow®, our rolled products are ideal for architectural roofing, architectural cladding and interior design.

Available manufacturing options:

- Rolling thicknesses: from 0,2 mm to 3 mm
- Rolling widths: from 70 mm to 1.320 mm
- Coil weights: from 50 kg to 10.000 kg

elZinc Alkimi

Zinc cladding and roofing allows a great deal of freedom when designing. The elZinc Alkimi aesthetic finishes give character and authenticity to your architectural projects.

Manufactured from elZinc Natural, according to EN988 and ASTM B-69 standards, through a unique surface treatment carried out with elZinc technology and know-how, the elZinc Alkimi range respects and maintains intact the zinc's original properties.

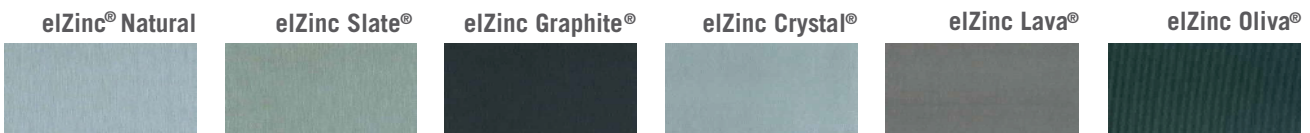

elZinc Rainbow®

elZinc Rainbow® is a range of colored architectural zinc which combines zinc elegance with the richness of colours. Available in 6 standard attractive finishes – red, blue, green, black, gold and brown – elZinc Rainbow® harmoniously integrates into its surroundings.

Produced according to EN988 and ASTM B-69 standards, elZinc Rainbow® is a pre-treated zinc on which mineral pigments are applied. Its organic coating is a very attractive and durable finish that provides additional protection against corrosion.

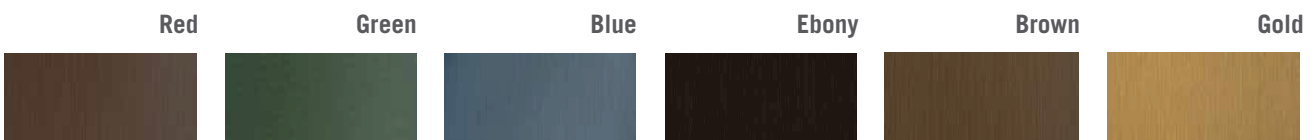

In addition to the classic six shades of the elZinc Rainbow range, elZinc offers the possibility of creating custom finishes for your project.

Matrix: Standing Seam

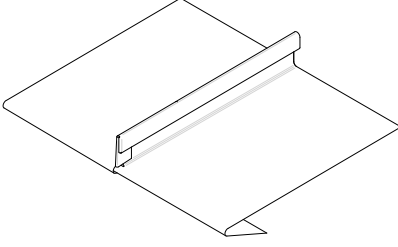
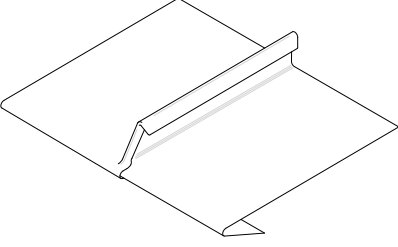
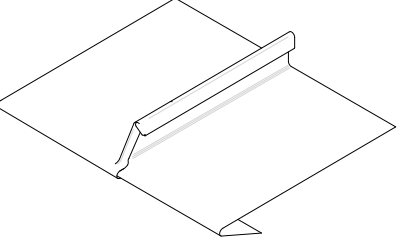
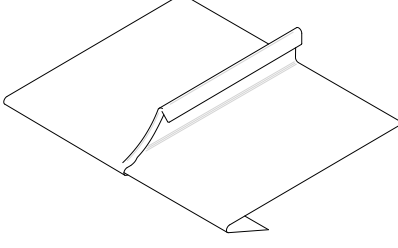
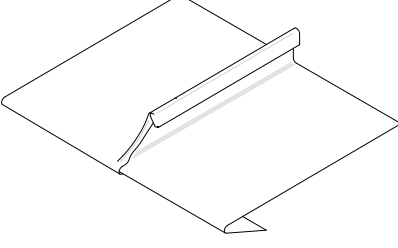
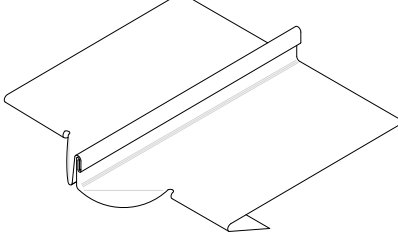
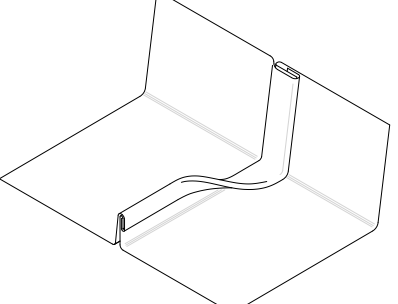
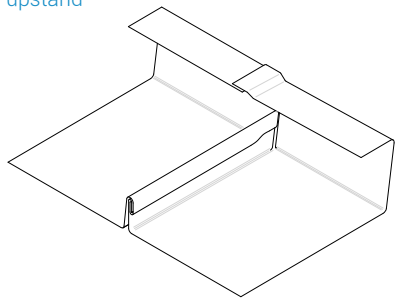
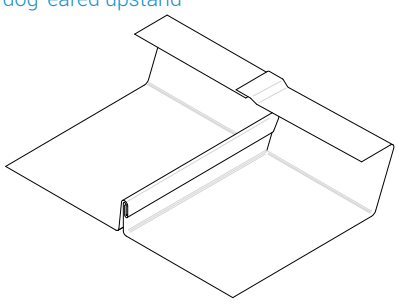
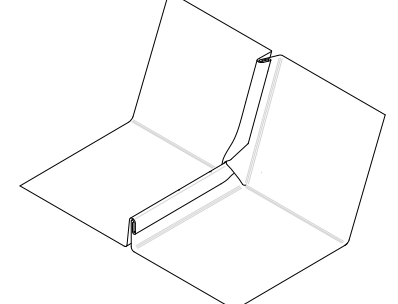
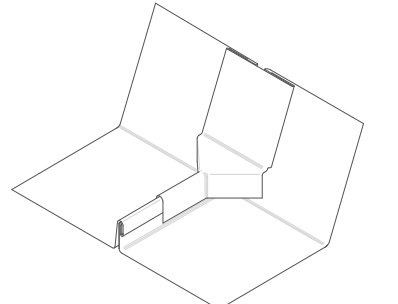
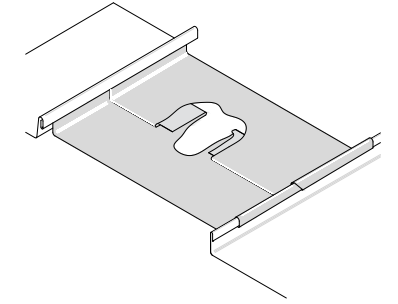
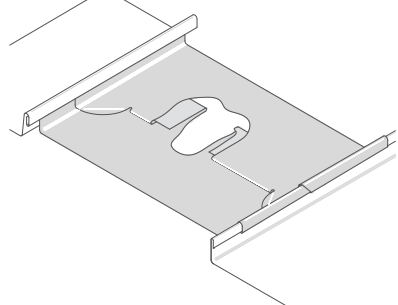
<p>DLSS I 1.2.1.01a - Squared foot</p> 	<p>DLSS I 1.2.1.02a - Chamfered foot</p> 	<p>DLSS I 1.2.1.02b - Chamfered foot</p> 
<p>DLSS I 1.2.1.03a - Curved foot</p> 	<p>DLSS I 1.2.1.03b - Curved foot</p> 	<p>DLSS I 1.2.1.05 - Swabian foot</p> 
<p>DLSS I 1.2.2.01 - Turned down upstand</p> 	<p>DLSS I 1.2.2.02a - Straight dog-eared upstand</p> 	<p>DLSS I 1.2.2.02b - Preformed straight dog-eared upstand</p> 
<p>DLSS I 1.2.2.03a - Pinched seam</p> 	<p>DLSS I 1.2.2.03b - Saddled pinched seam</p> 	<p>DLSS I 2.1.01a - Single lock cross welt</p> 
<p>DLSS I 2.1.01b - Single lock cross welt</p> 		

Squared foot - DLSS I 1.2.1.01a

01

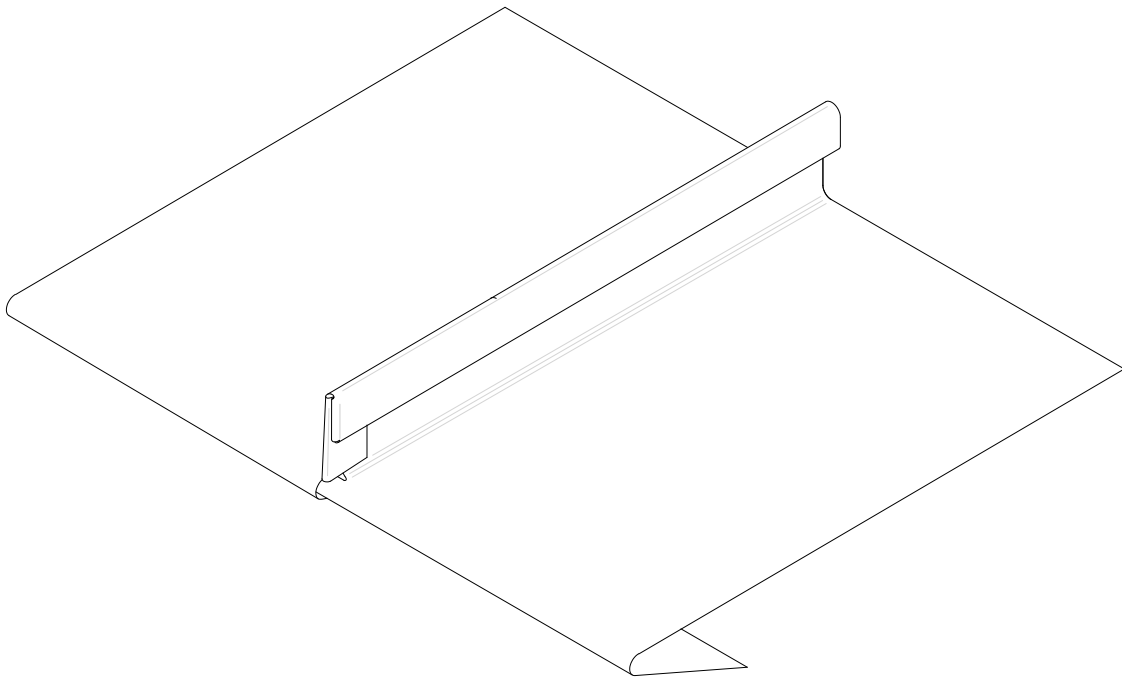

Scale 1/2

All dimensions are indicative unless specified on the drawing

· OK > 3°

Squared foot - DLSS I 1.2.1.01a

01



For correct printing, please make sure to set your printer to a 100% scale.

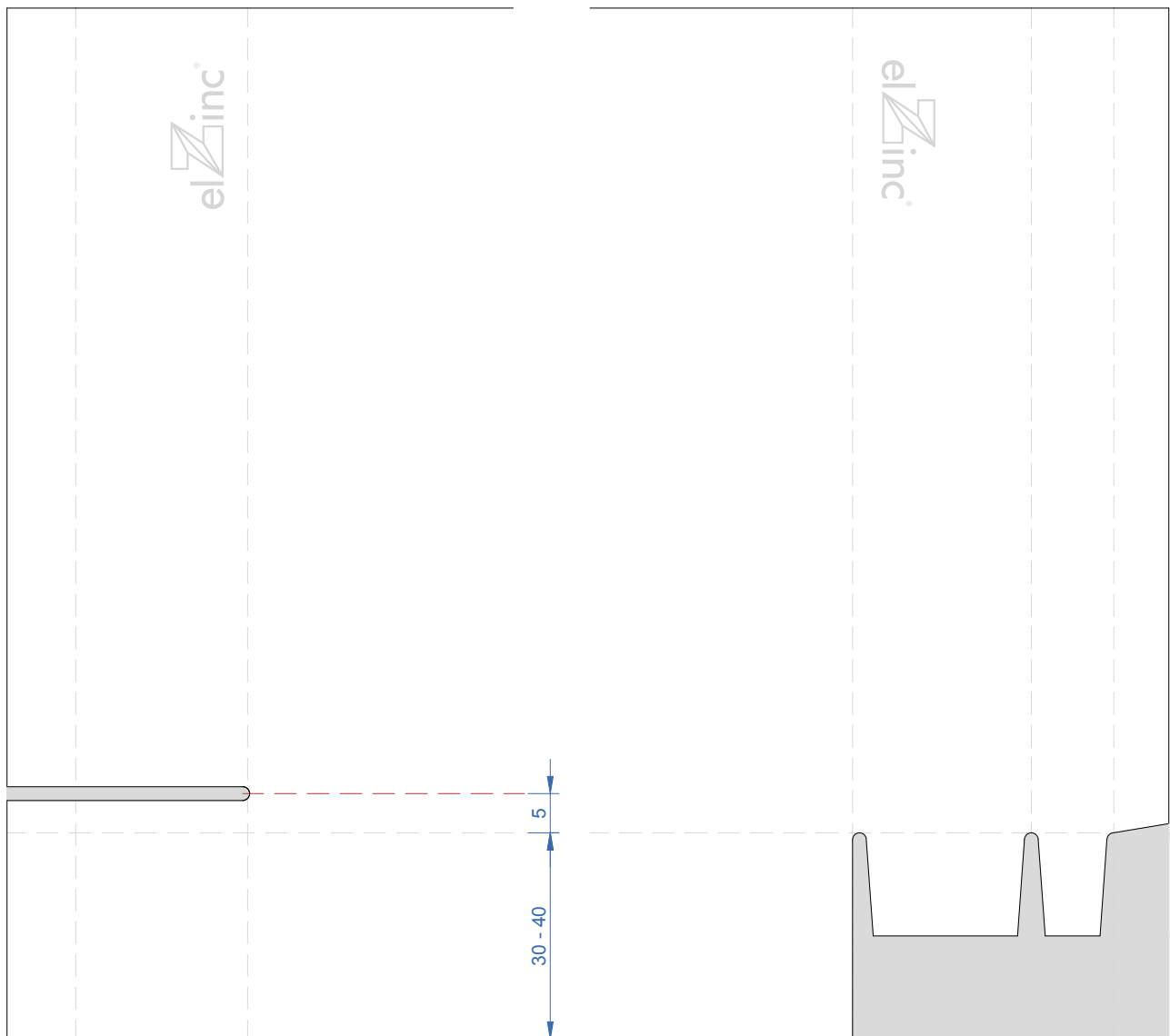

Scale 1/1

All dimensions are indicative unless specified on the drawing

- We recommend using a nibbler to avoid splits.

Squared foot - DLSS I 1.2.1.01a

1/2

01

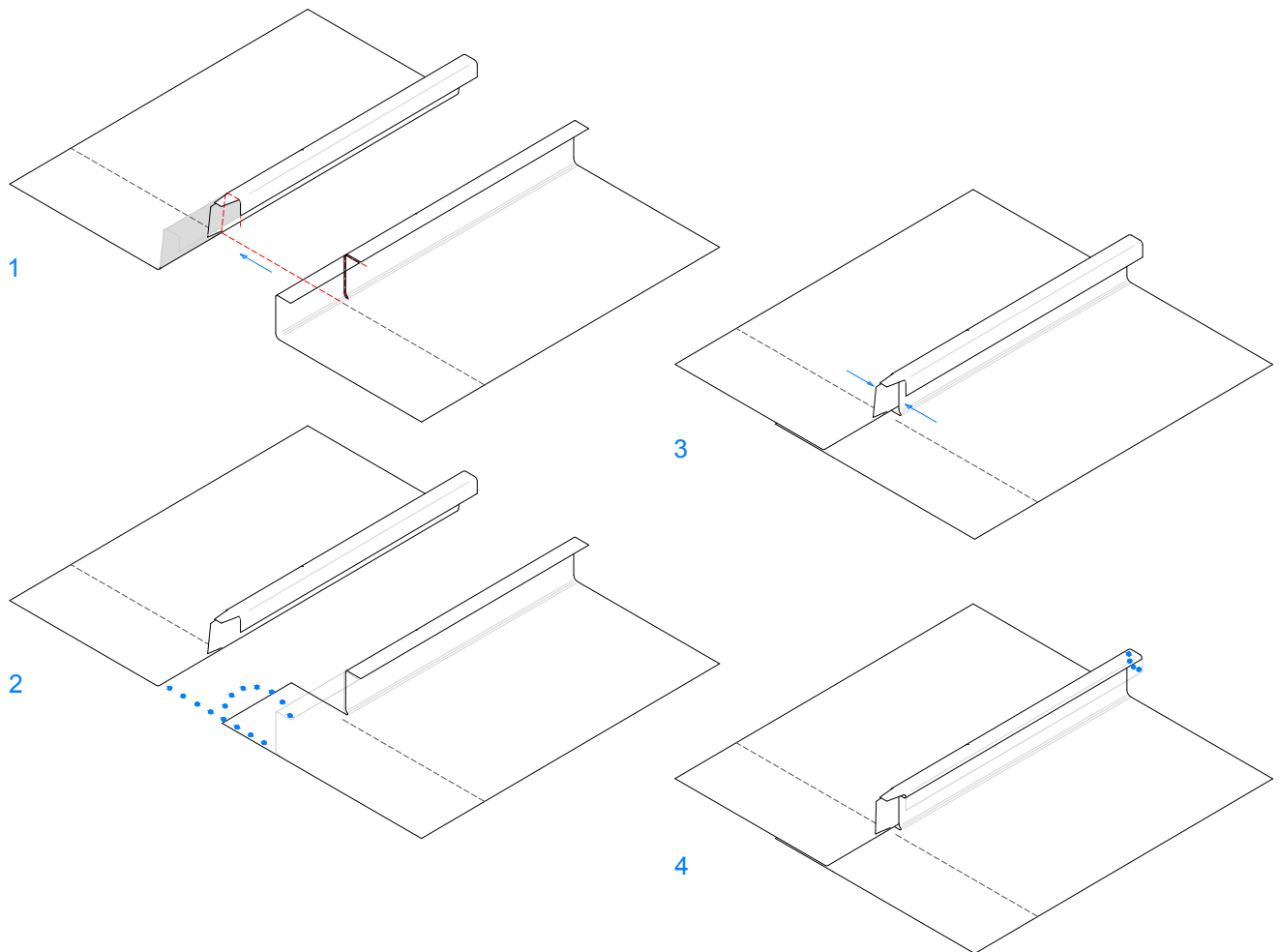

Scale 1/4

All dimensions are indicative unless specified on the drawing

Step 1



Step 2



Step 4



Squared foot - DLSS I 1.2.1.01a

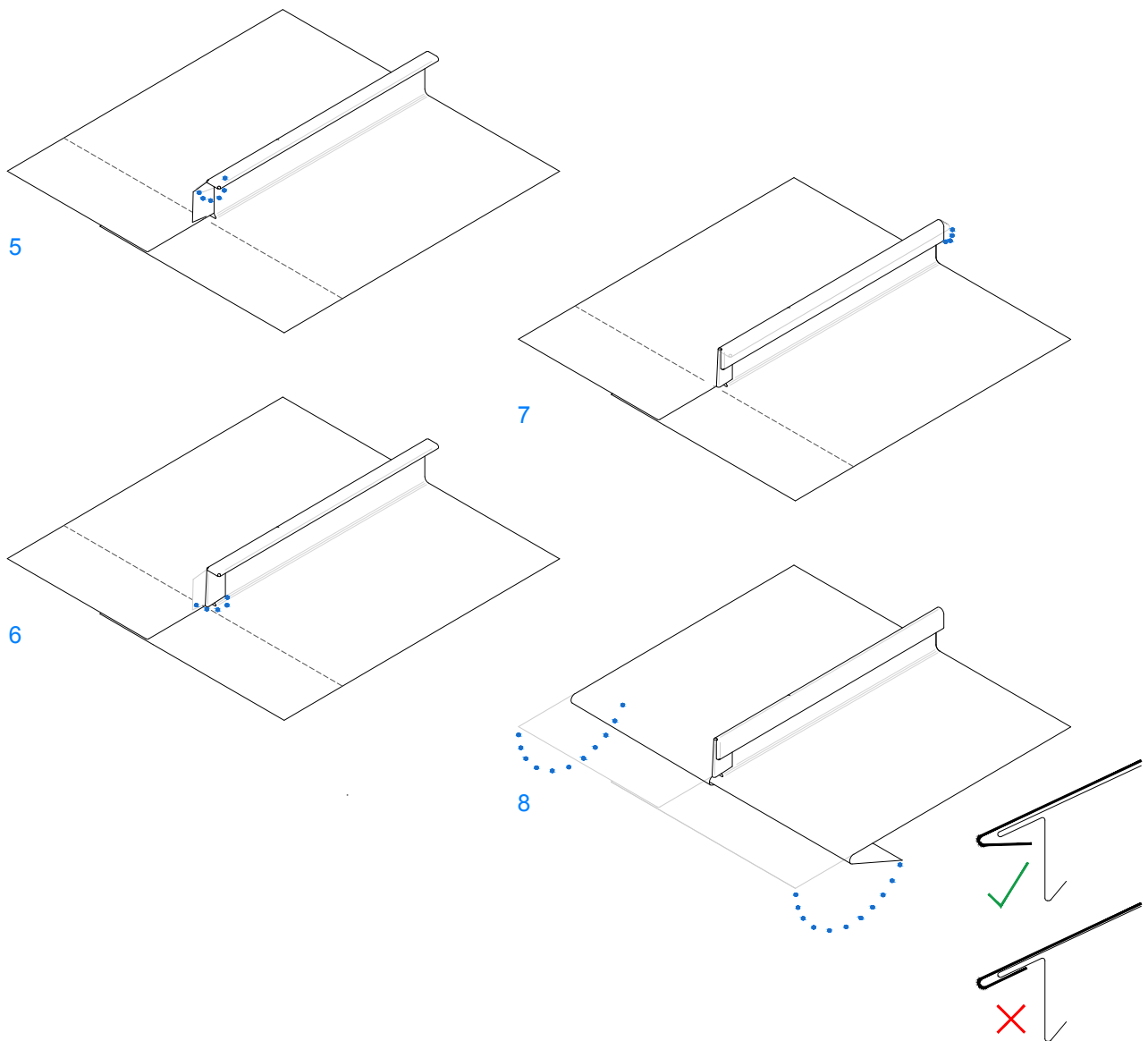

Scale 1/4

All dimensions are indicative unless specified on the drawing



Chamfered foot - DLSS I 1.2.1.02a

01

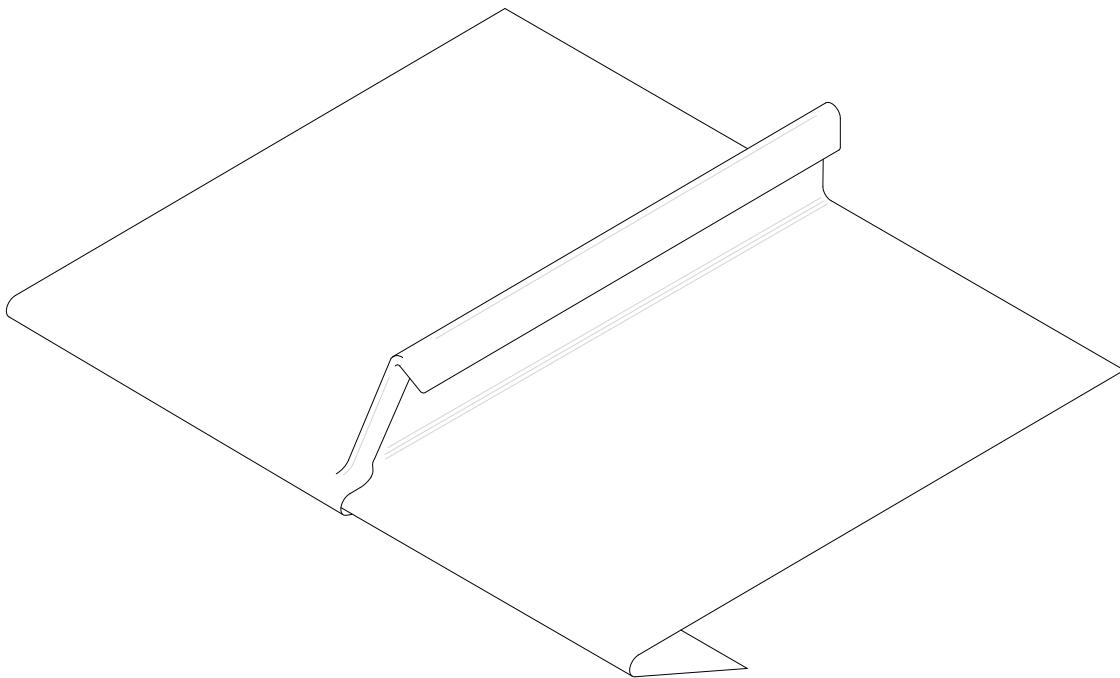

Scale 1/2

All dimensions are indicative unless specified on the drawing

- OK > 3°
- Most common foot termination
- Alternative to DLSS 1.2.1.02b.
- Avoids small hole at top of chamfer

Chamfered foot - DLSS I 1.2.1.02a

01



Optional cut away

For correct printing, please make sure to set your printer to a 100% scale.



Overcloak

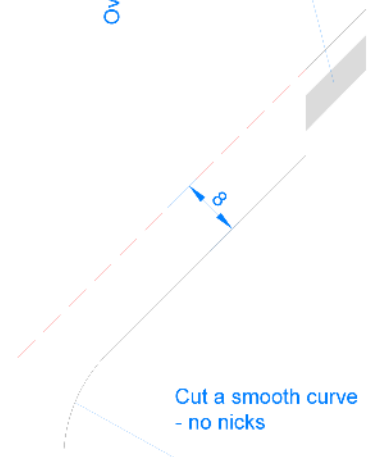
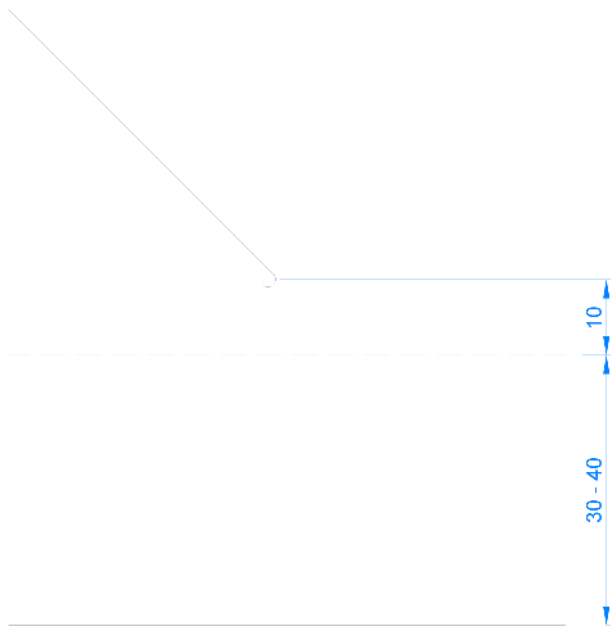

Scale 1/1

All dimensions are indicative unless specified on the drawing

- We recommend using a notcher on the undercloak to avoid splits

Chamfered foot - DLSS I 1.2.1.02a

1/3

01

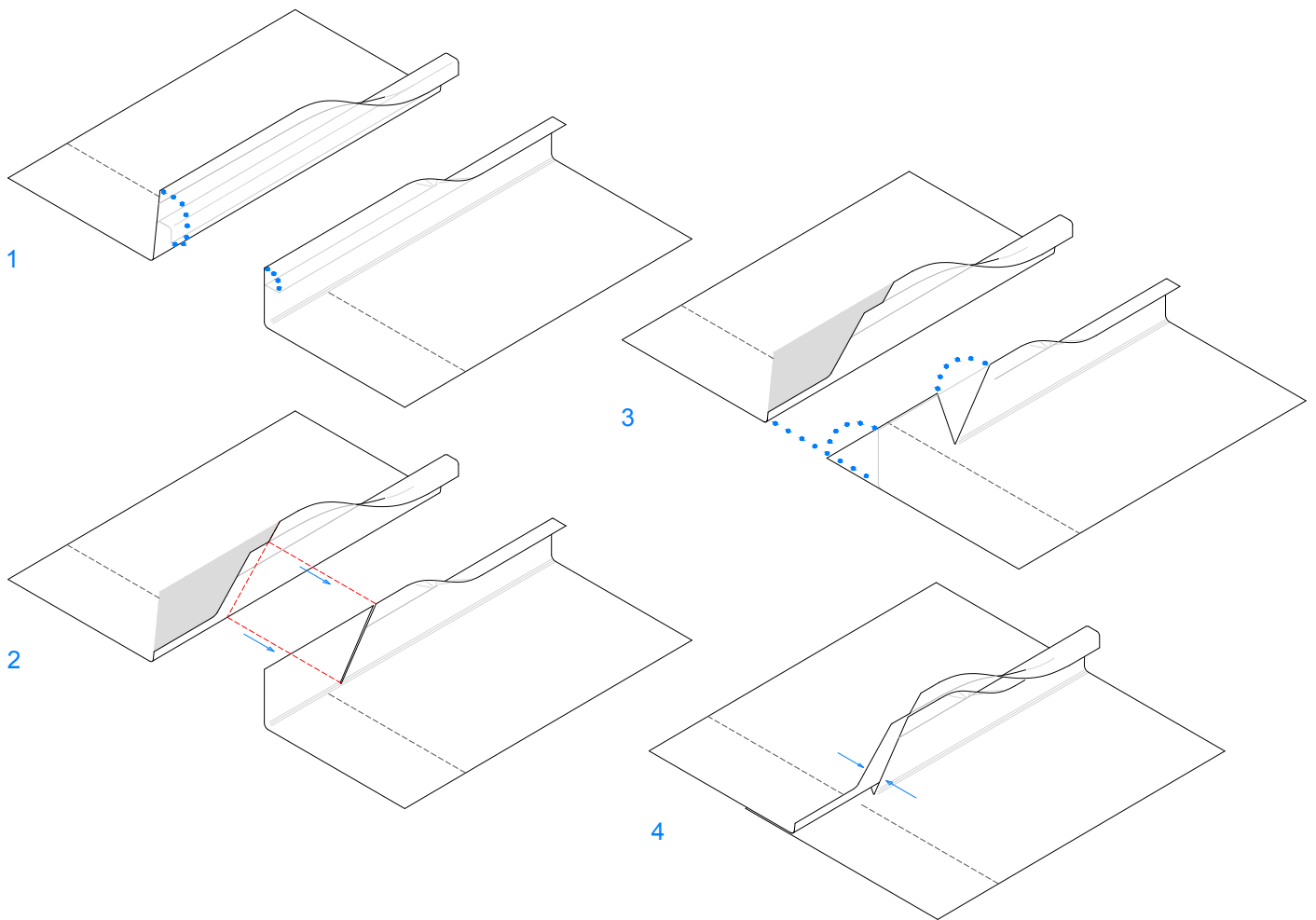

Scale 1/4

All dimensions are indicative unless specified on the drawing

Step 1



Step 2



Step 3



Chamfered foot - DLSS I 1.2.1.02a

2/3

01

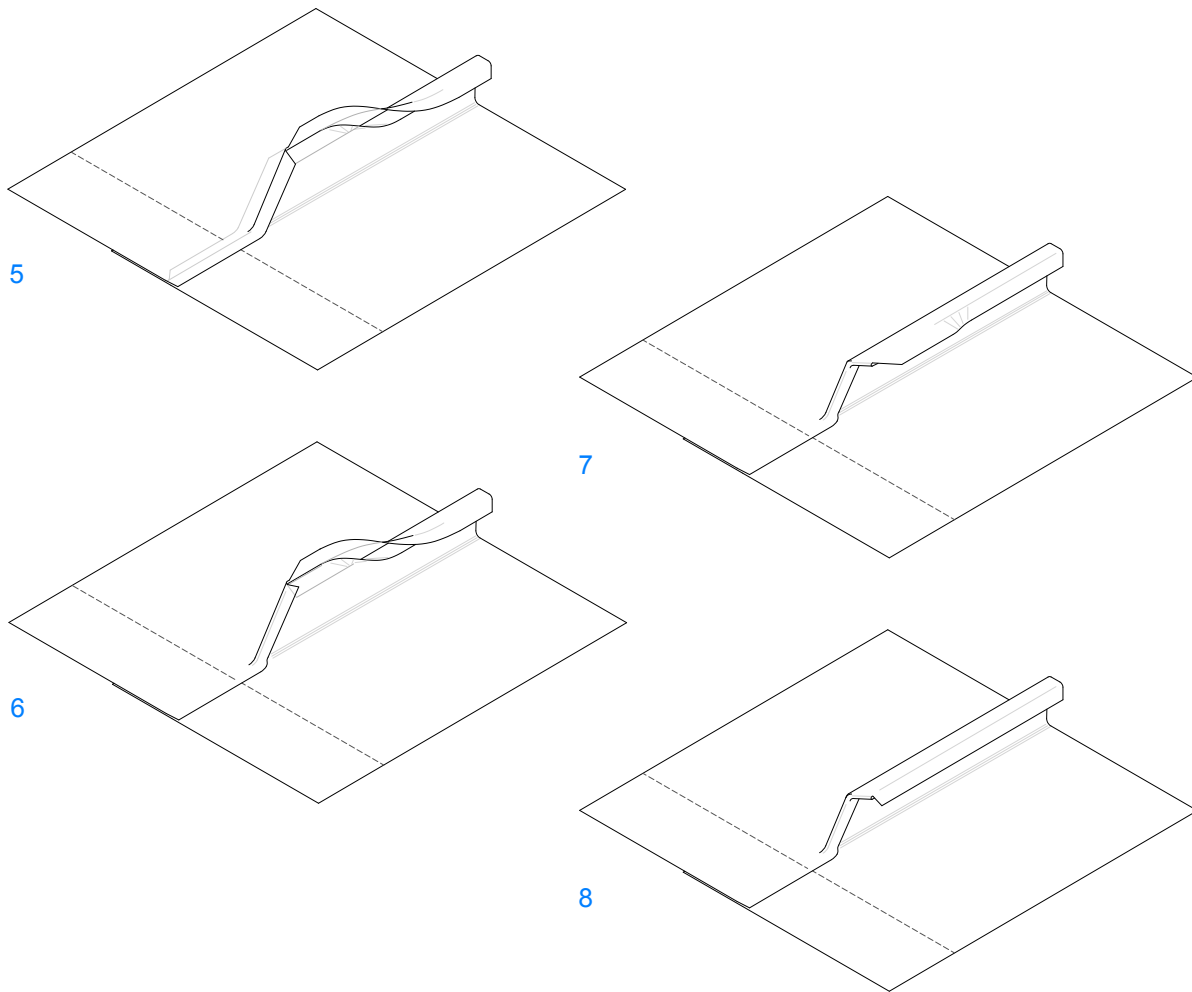

Scale 1/4

All dimensions are indicative unless specified on the drawing

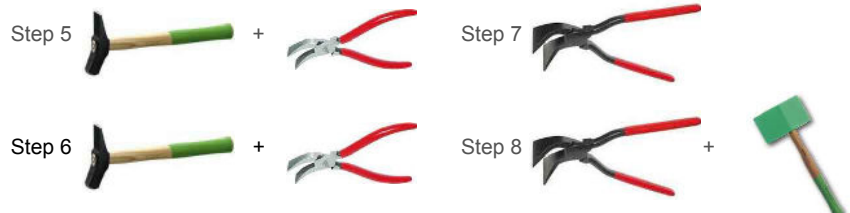

Chamfered foot - DLSS I 1.2.1.02a

3/3

01

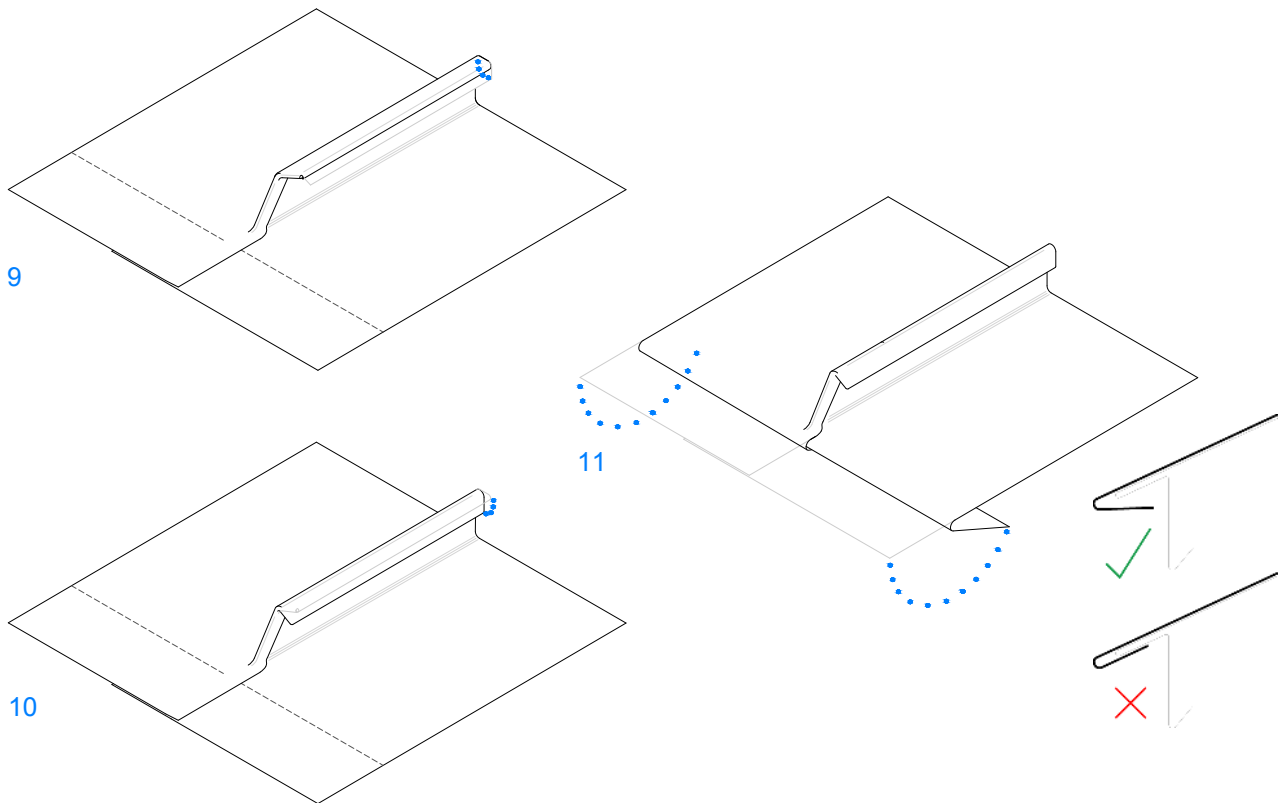

Scale 1/4

All dimensions are indicative unless specified on the drawing



Chamfered foot - DLSS I 1.2.1.02b

01

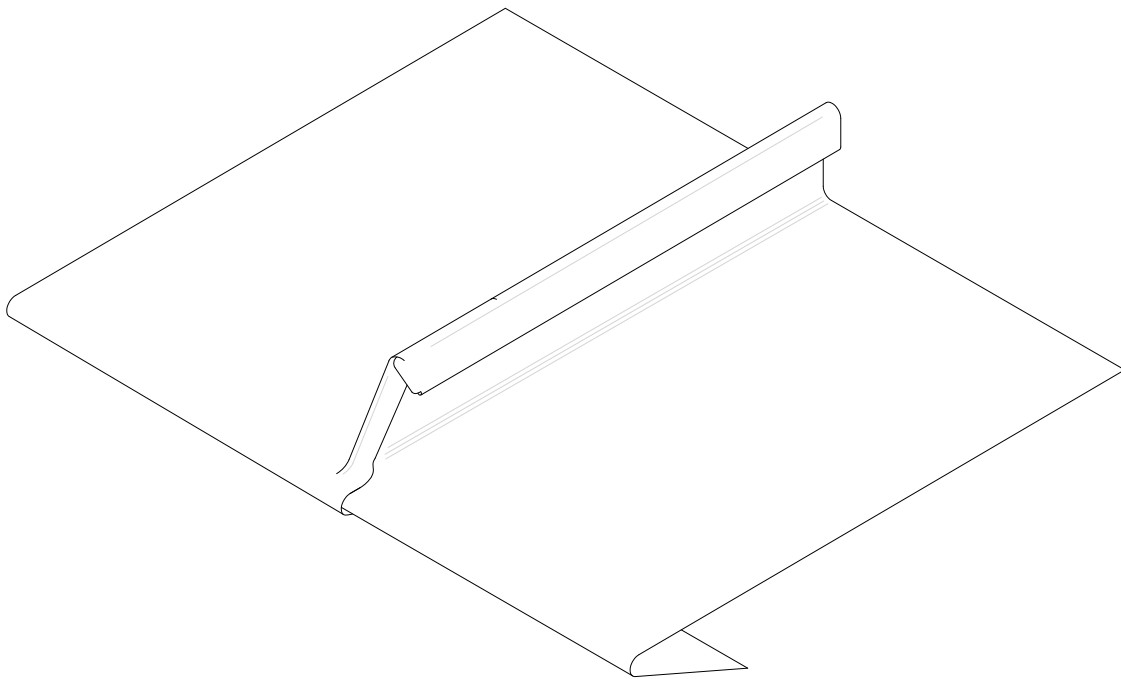

Scale 1/2

All dimensions are indicative unless specified on the drawing

Chamfered foot - DLSS I 1.2.1.02b

01



For correct printing, please make sure to set your printer to a 100% scale.

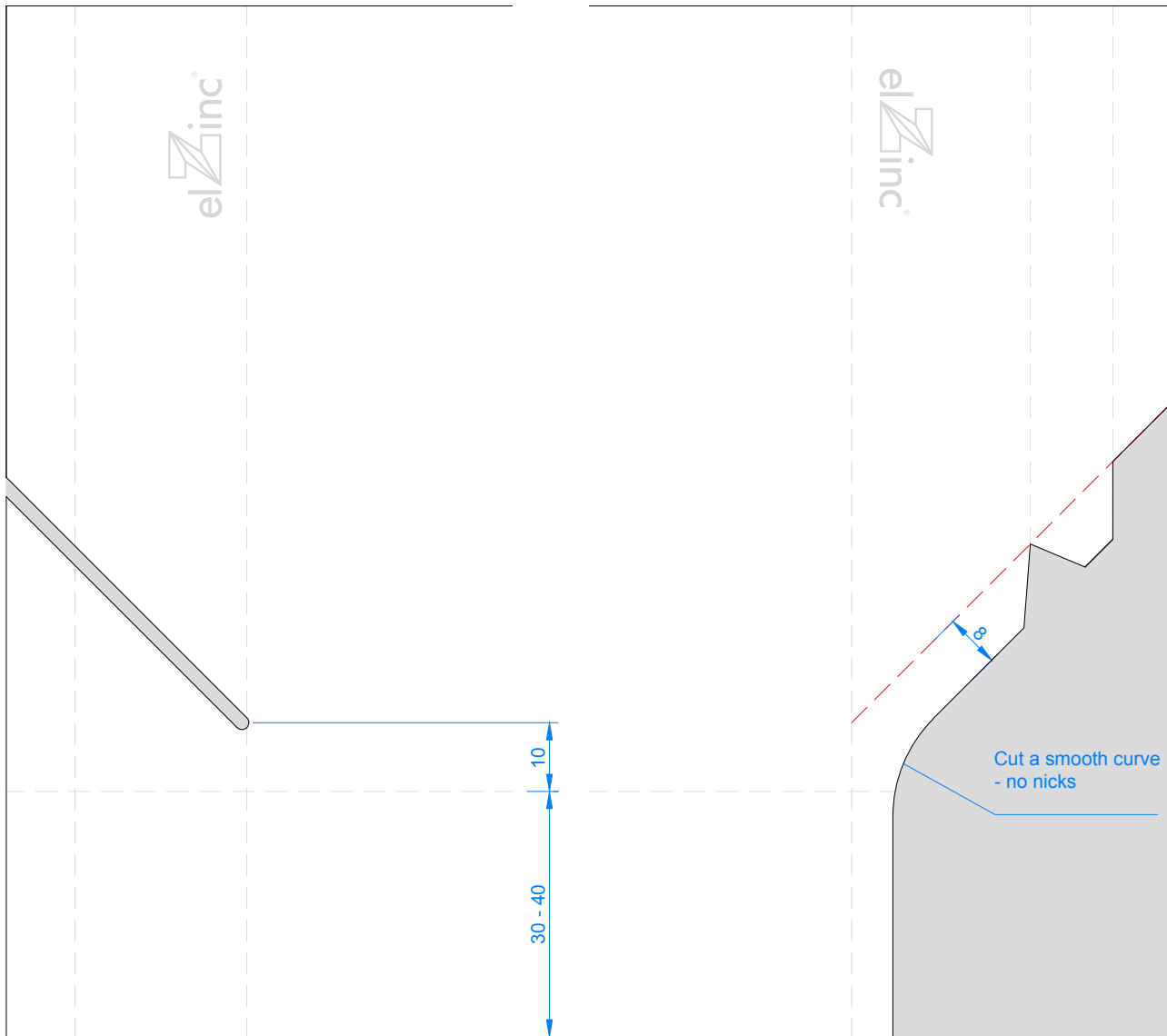

Scale 1/1

All dimensions are indicative unless specified on the drawing

- We recommend using a notcher on the undercloak to avoid splits

Chamfered foot - DLSS I 1.2.1.02b

1/2

01

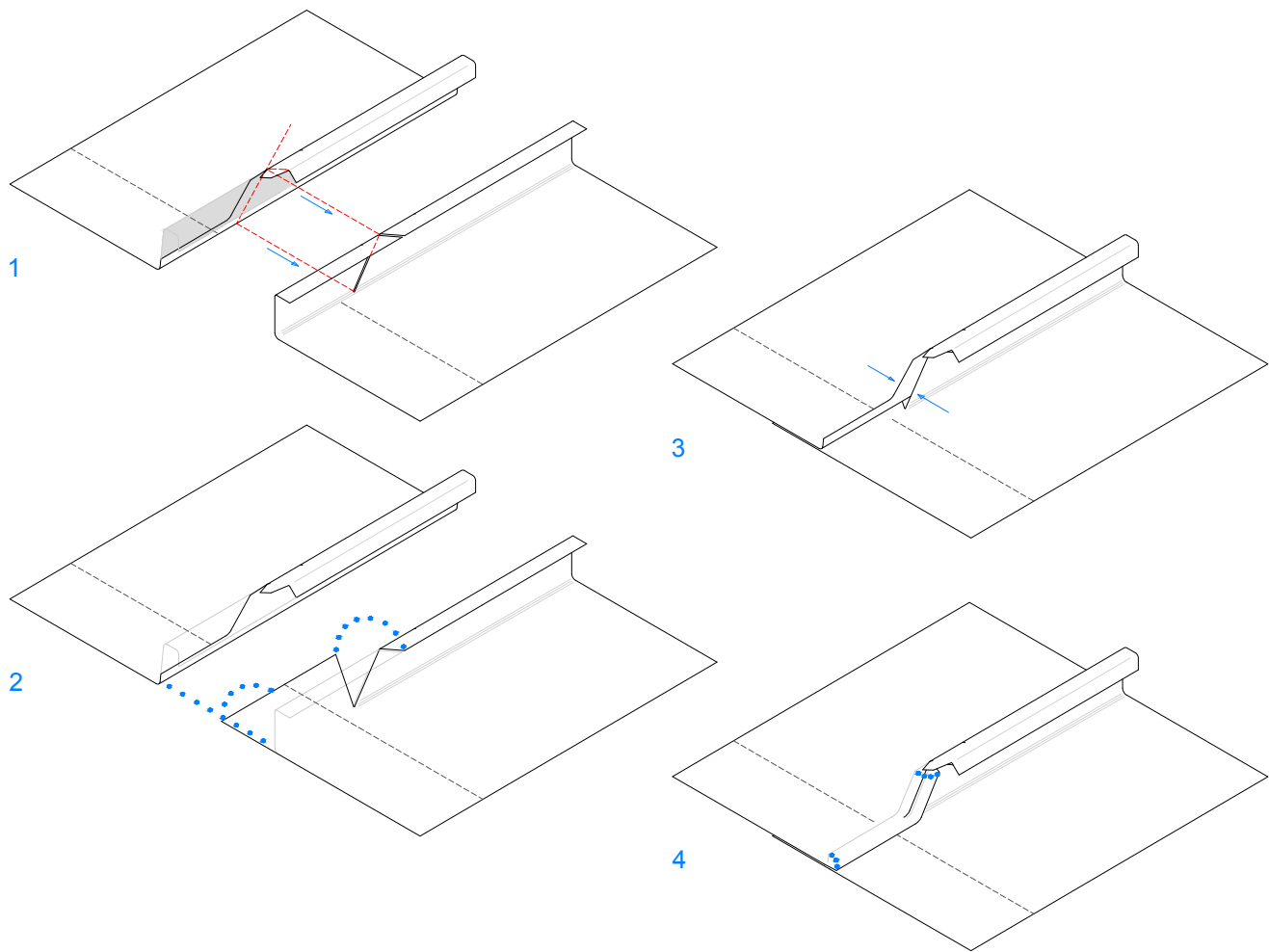

Scale 1/4

All dimensions are indicative unless specified on the drawing

Step 1



Step 2



Step 4



Chamfered foot - DLSS I 1.2.1.02b

2/2

01

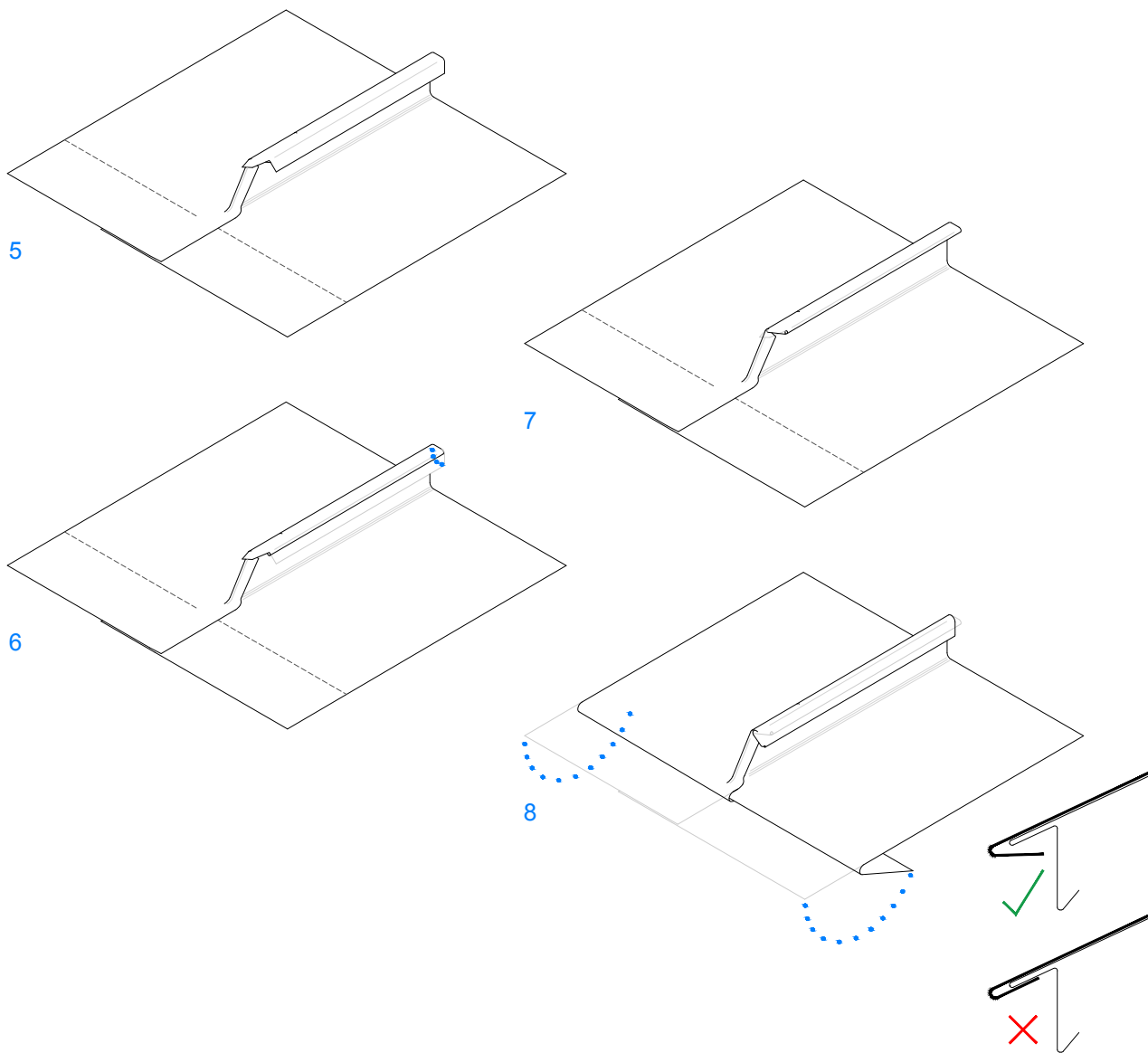

Scale 1/4

All dimensions are indicative unless specified on the drawing



Curved foot - DLSS I 1.2.1.03a

01

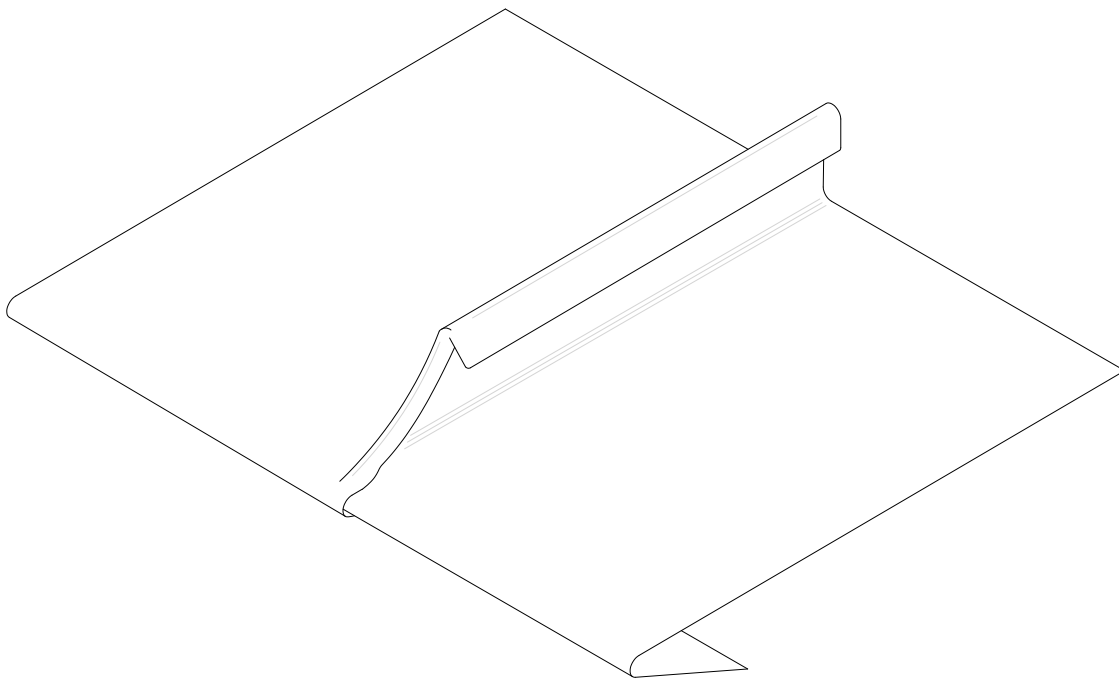

Scale 1/2

All dimensions are indicative unless specified on the drawing

- OK > 3°
- Decorative finish but more time consuming detail.
- Alternative to DLSS 1.2.1.03b

Curved foot - DLSS I 1.2.1.03a

01



For correct printing, please make sure to set your printer to a 100% scale.

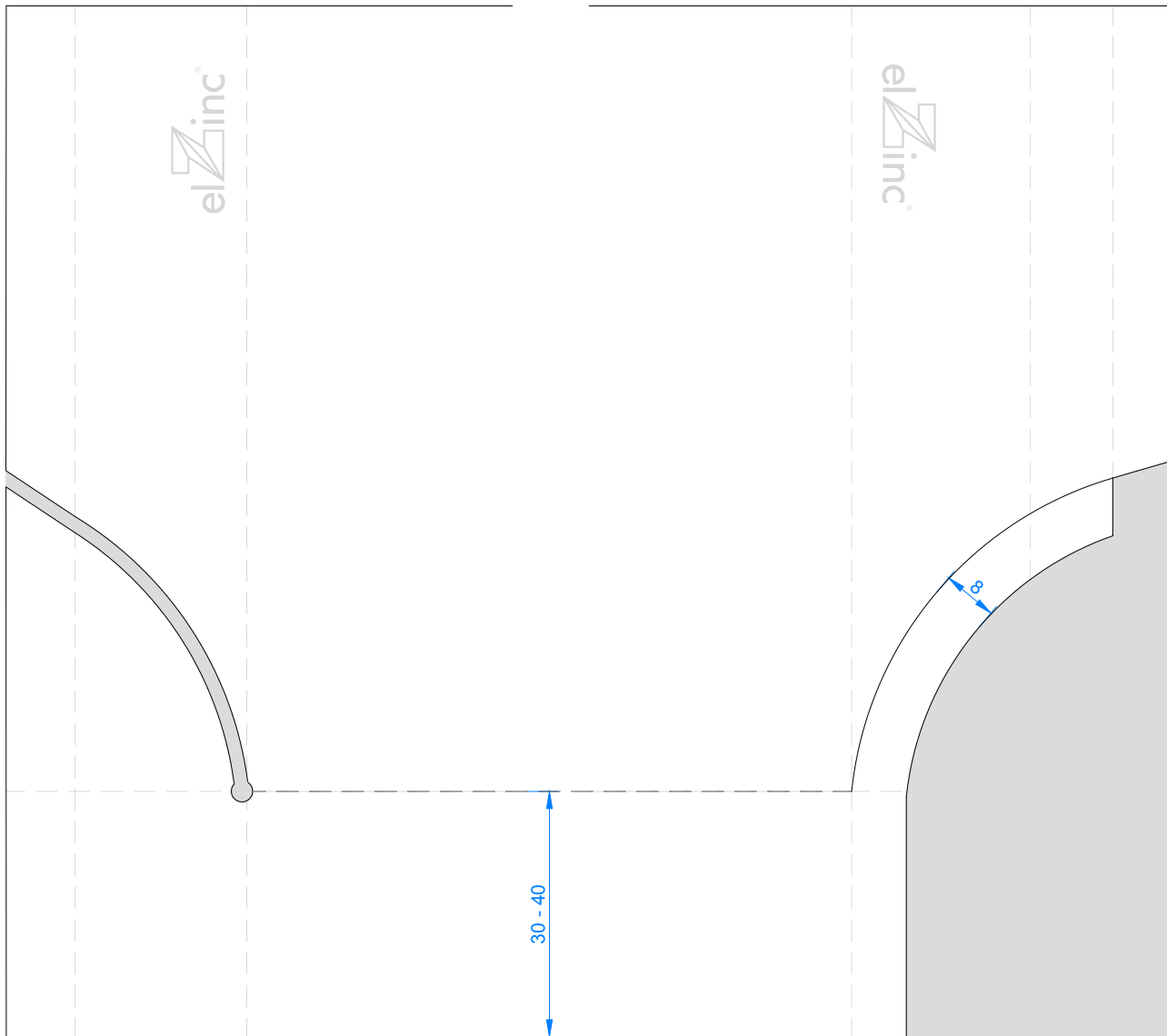

Scale 1/1

All dimensions are indicative unless specified on the drawing

- Make small hole at end of undercloak cut

Curved foot - DLSS I 1.2.1.03a

1/3

01

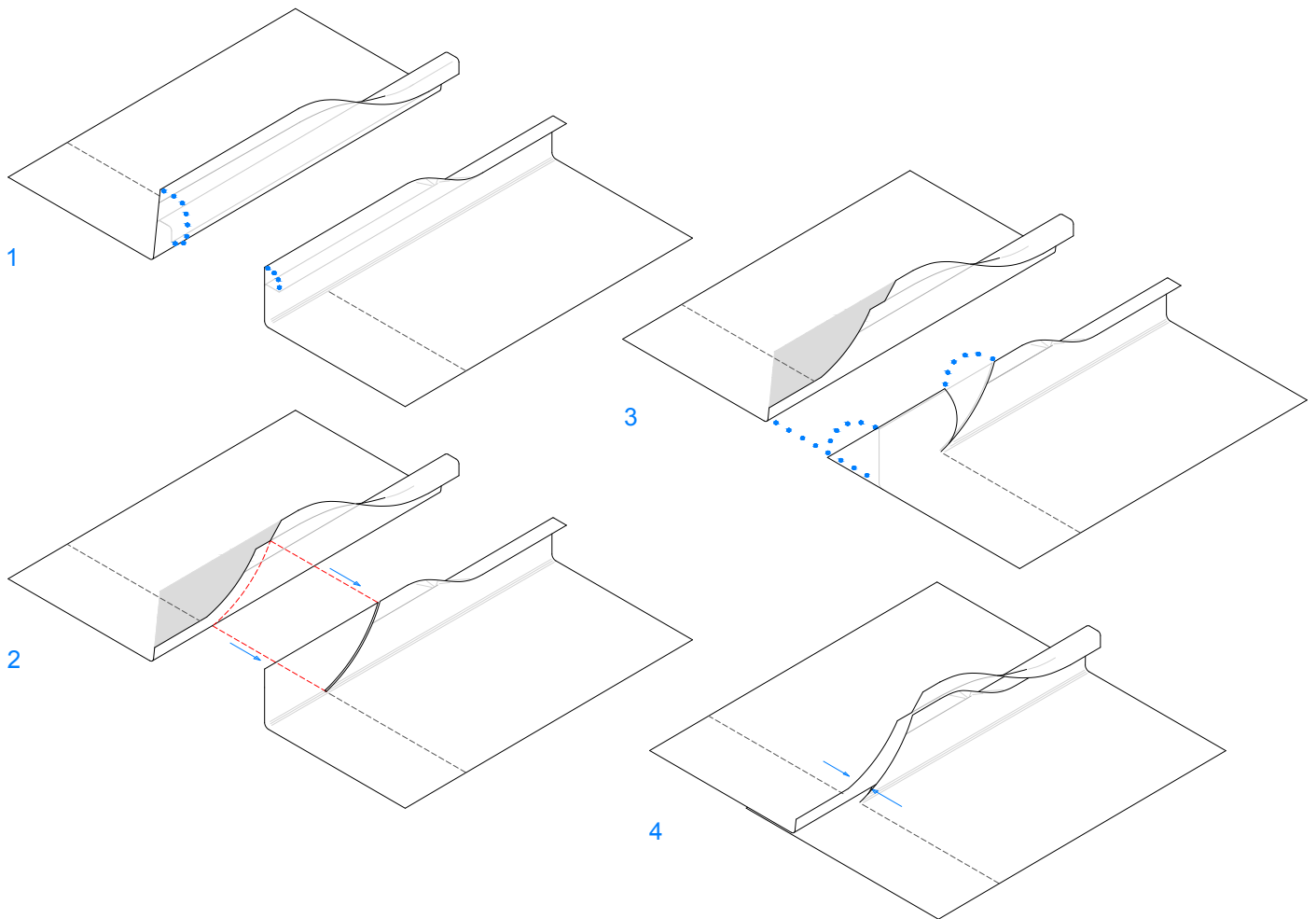

Scale 1/4

All dimensions are indicative unless specified on the drawing

Step 1



Step 2



Step 3



Curved foot - DLSS I 1.2.1.03a

2/3

01

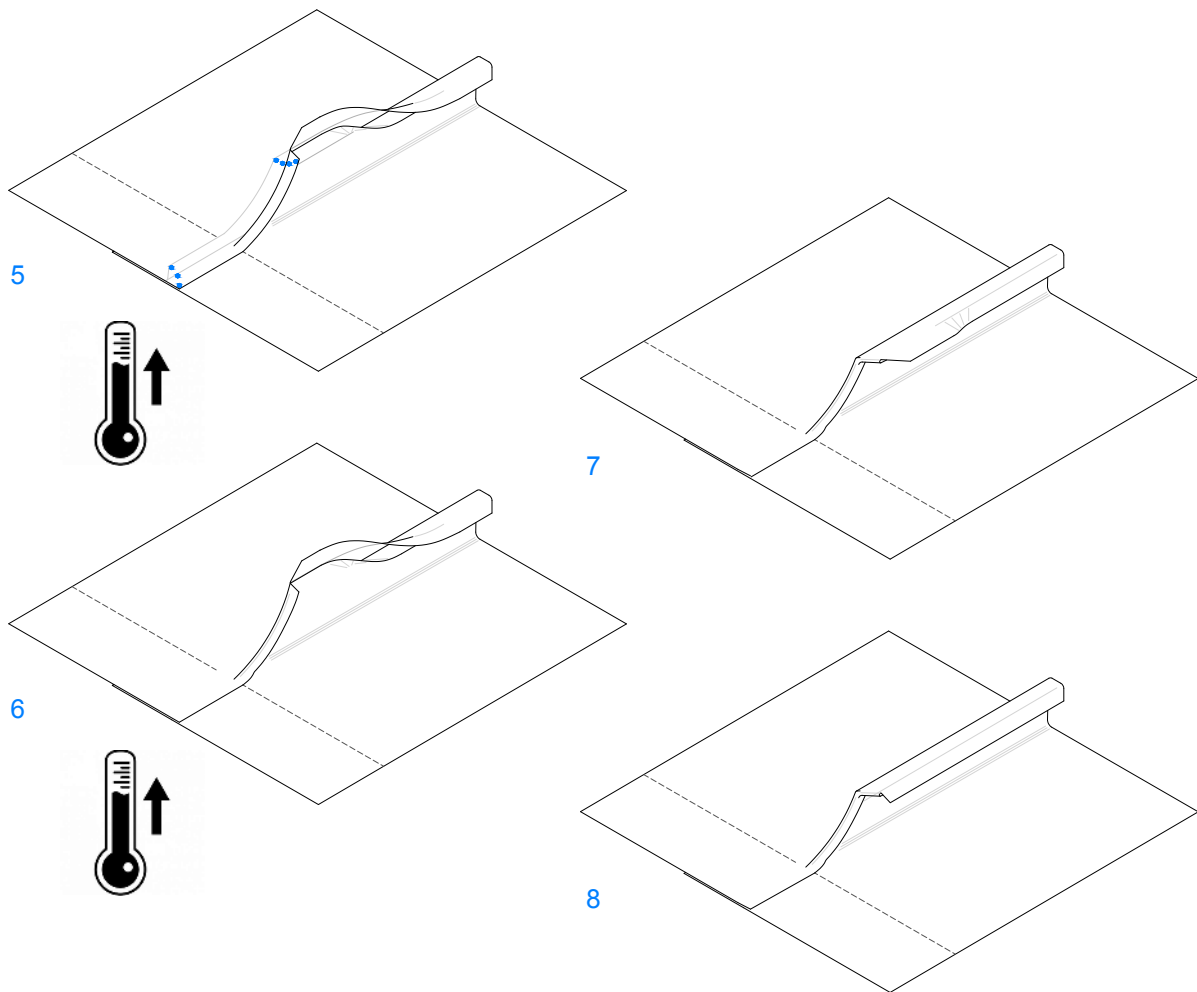

Scale 1/4

All dimensions are indicative unless specified on the drawing

· Steps 5 & 6: In cold weather warm zinc up before cobbling over



Curved foot - DLSS I 1.2.1.03a

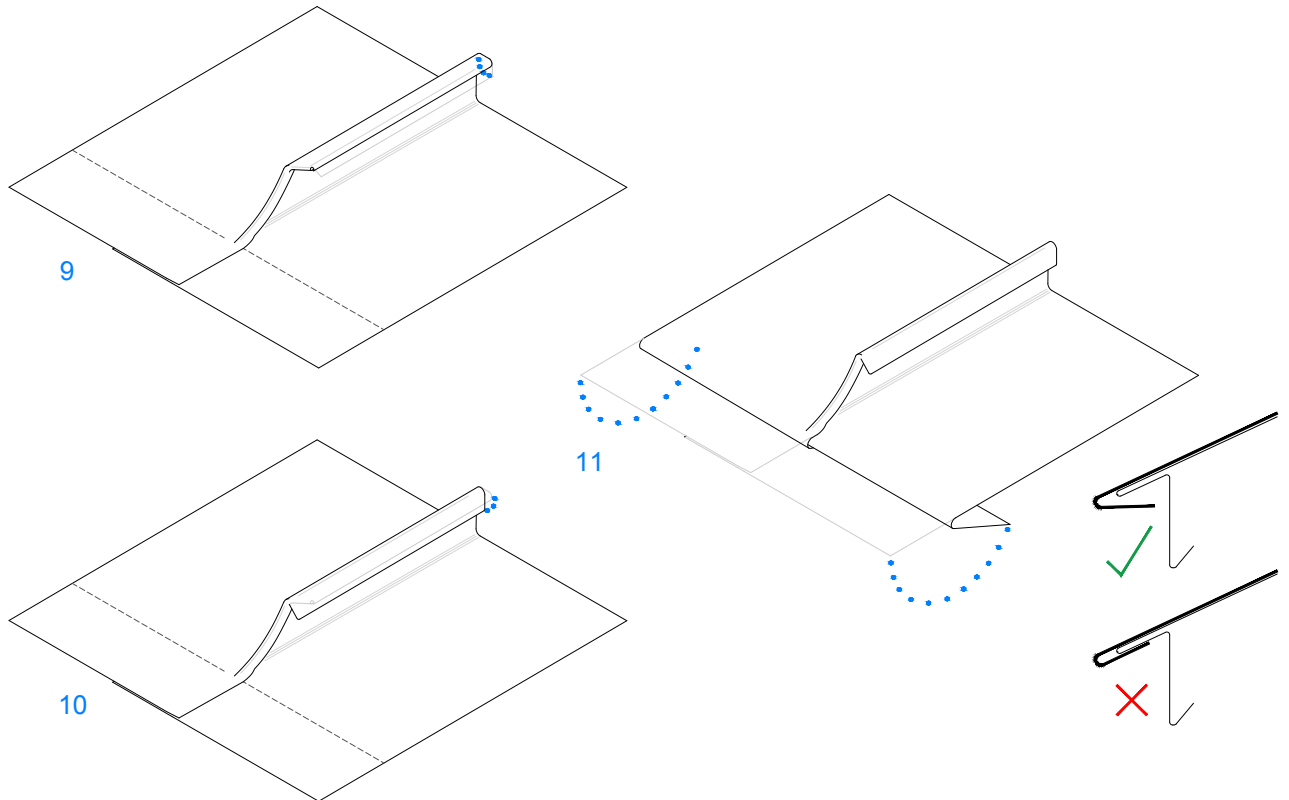

Scale 1/4

All dimensions are indicative unless specified on the drawing



Curved foot - DLSS I 1.2.1.03b

01

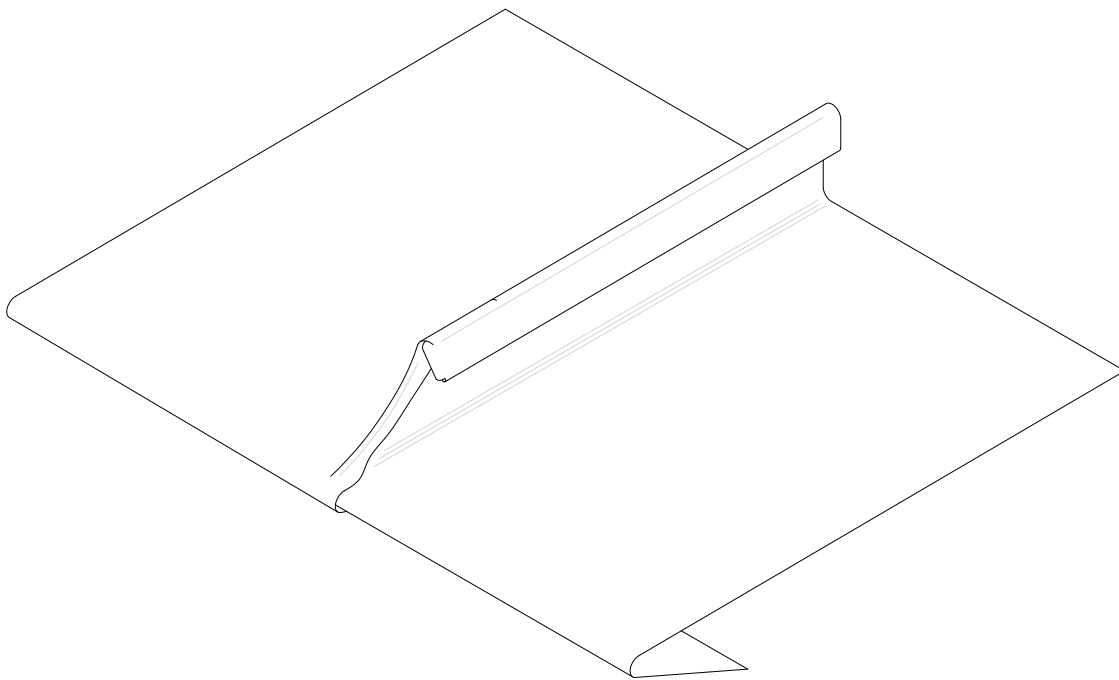

Scale 1/2

All dimensions are indicative unless specified on the drawing

- OK > 3°
- Decorative finish but more time consuming detail.
- Alternative to DLSS 1.2.1.03a
- Avoids opening of end of seam

Curved foot - DLSS I 1.2.1.03b

01



For correct printing, please make sure to set your printer to a 100% scale.

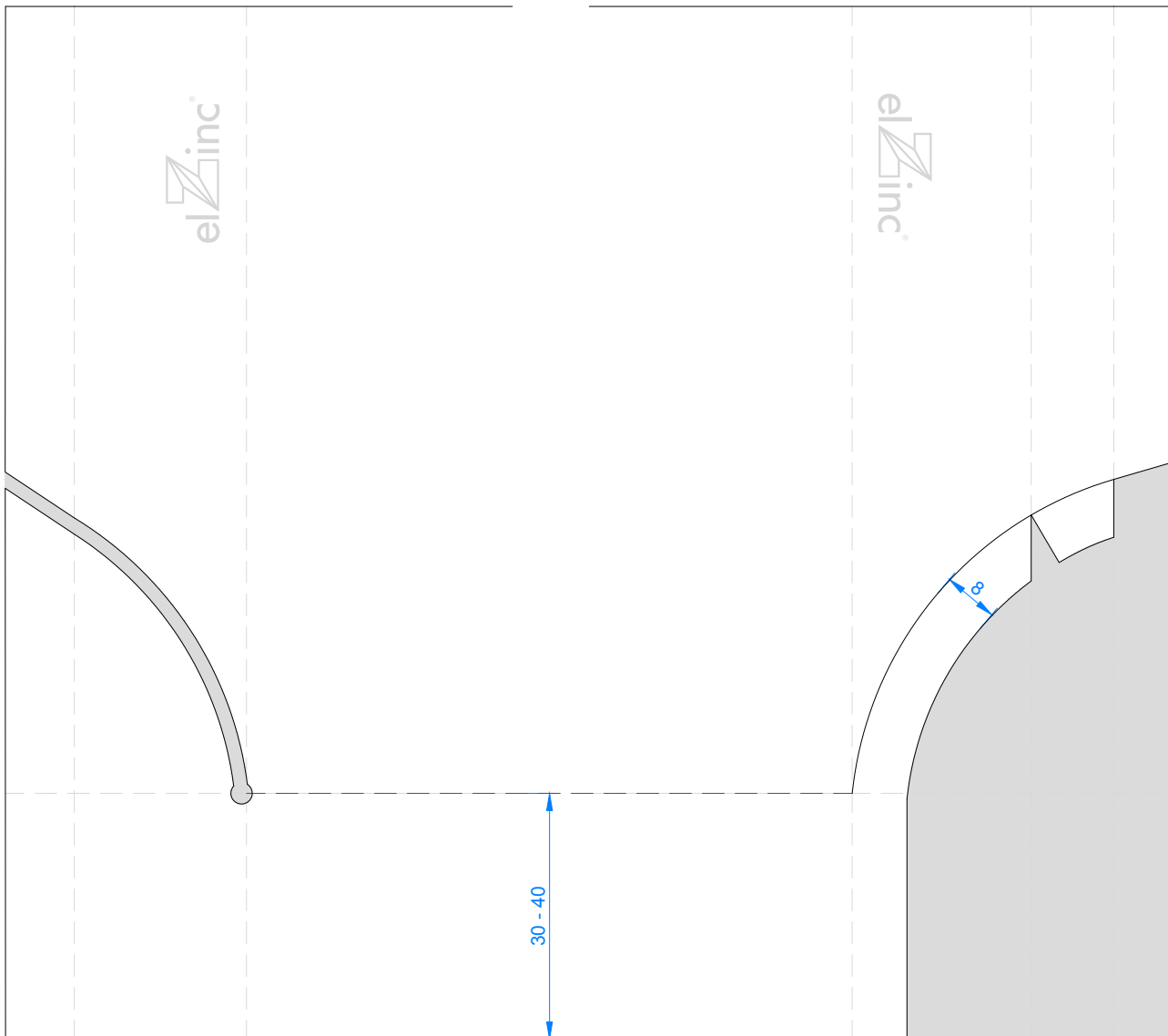

Scale 1/1

All dimensions are indicative unless specified on the drawing

- Make small hole at the end of undercloak cut

Curved foot - DLSS I 1.2.1.03b

1/2

01

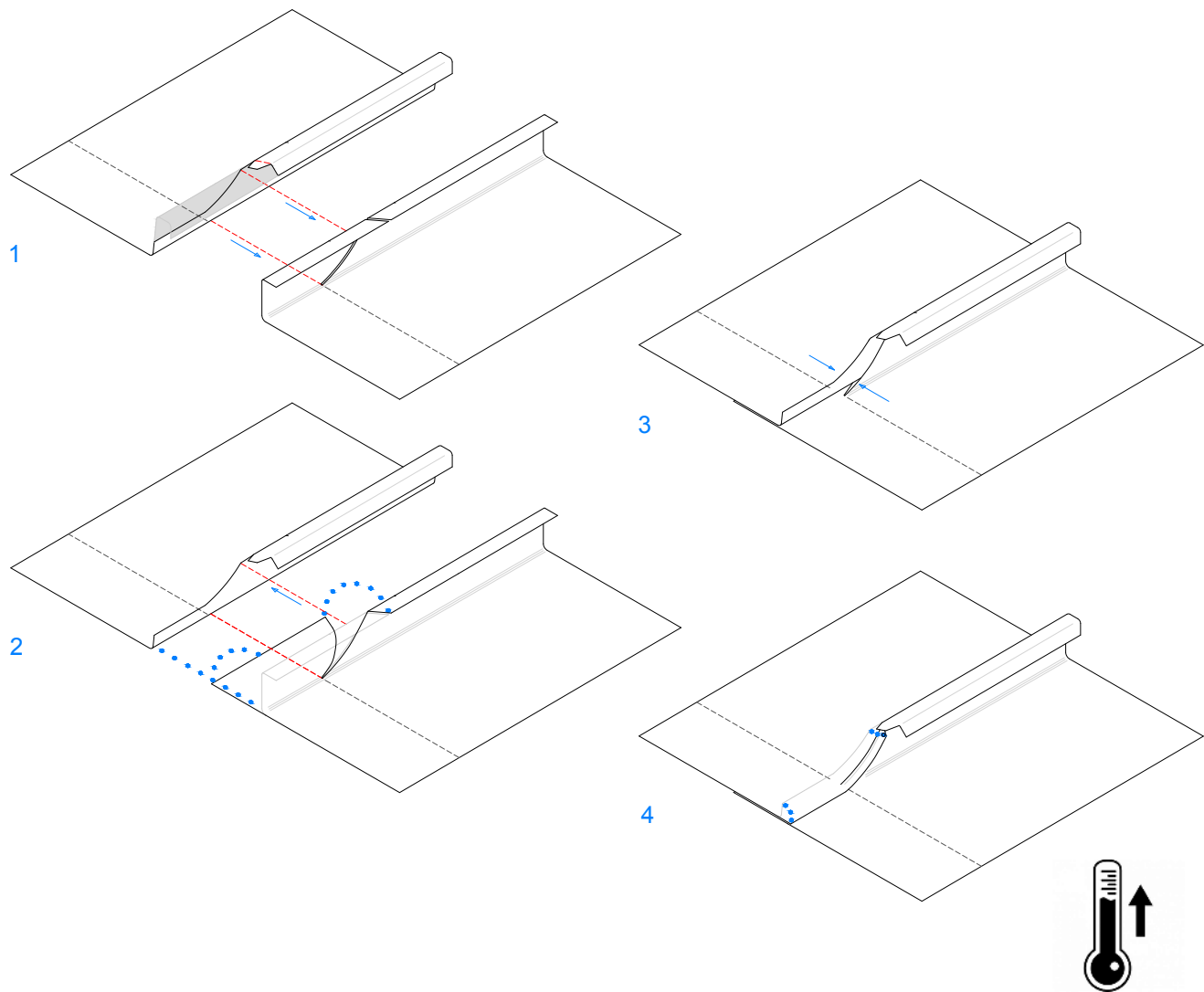

Scale 1/4

All dimensions are indicative unless specified on the drawing

· Step 4: In cold weather warm the zinc up before cobbling over.



Curved foot - DLSS I 1.2.1.03b

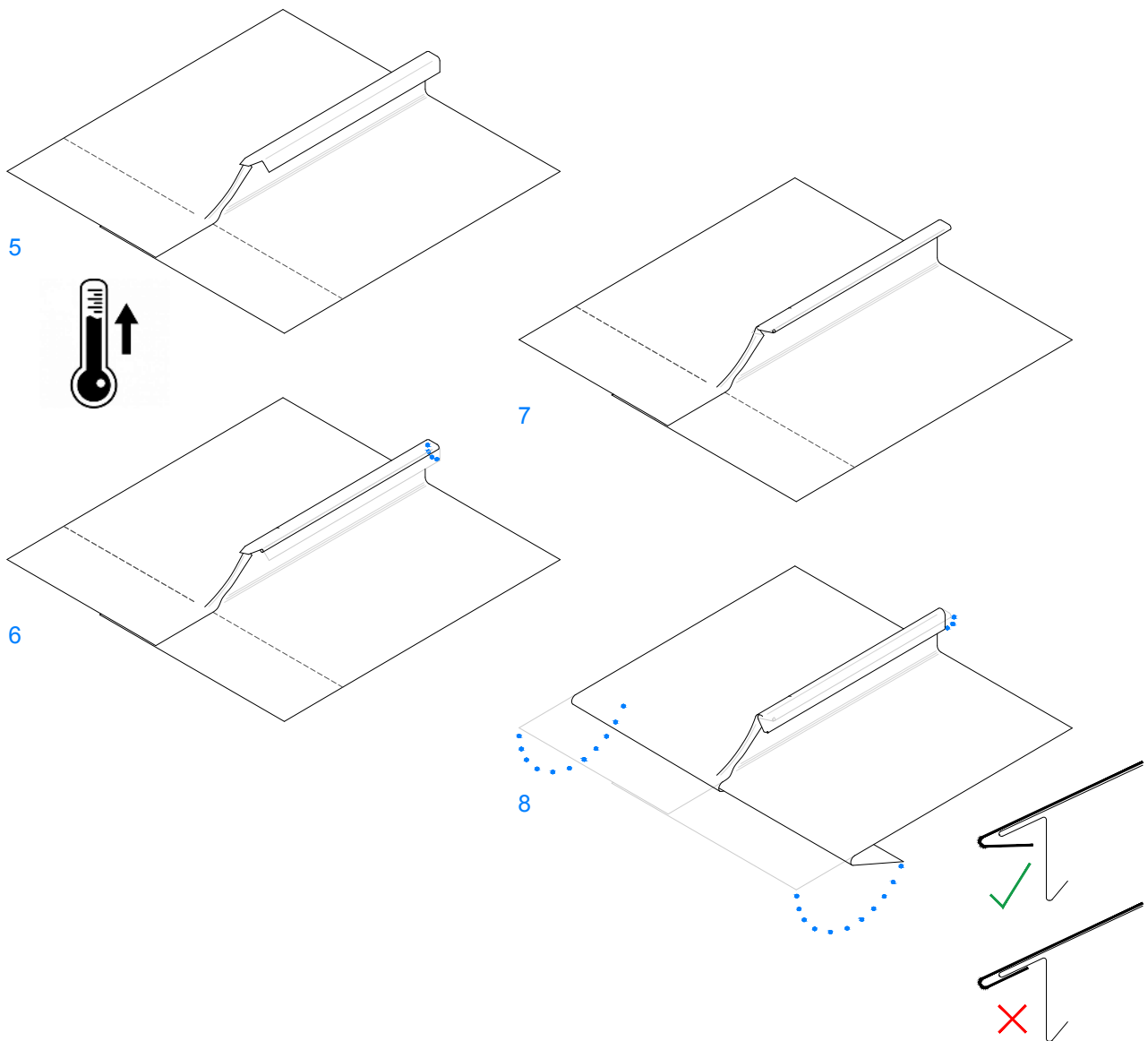

Scale 1/4

All dimensions are indicative unless specified on the drawing

· Step 5: In cold weather warm zinc up before cobbling over



Swabian foot - DLSS I 1.2.1.05

01

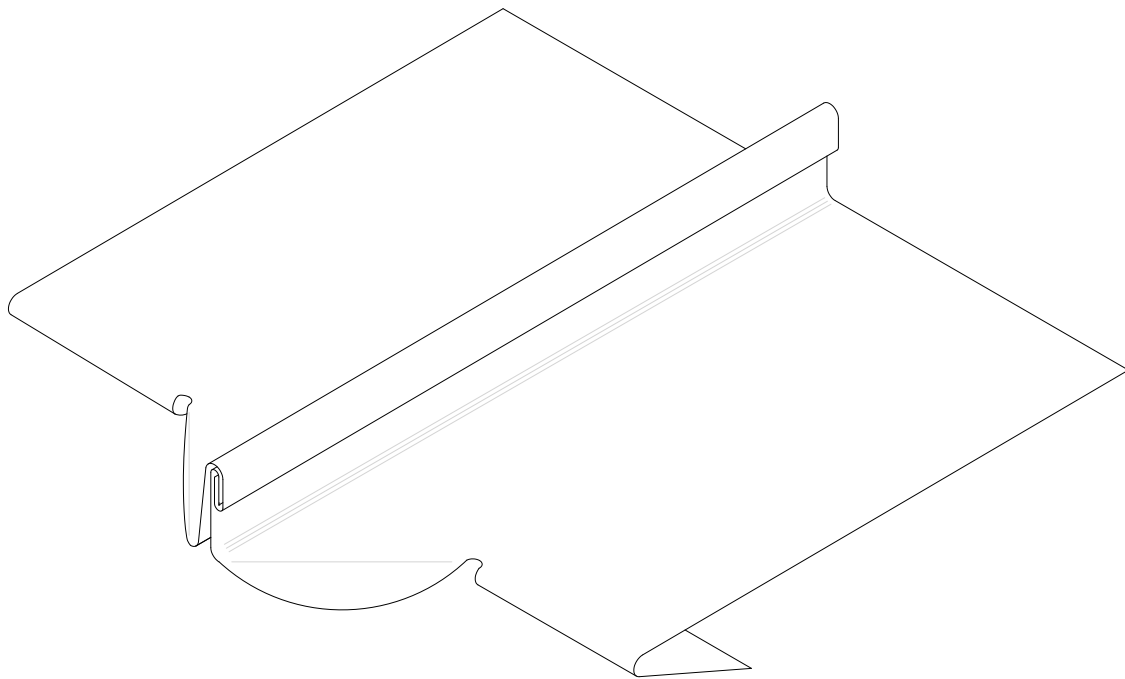

Scale 1/2

All dimensions are indicative unless specified on the drawing

-
- Easiest foot detail

Swabian foot - DLSS I 1.2.1.05

01



For correct printing, please make sure to set your printer to a 100% scale.

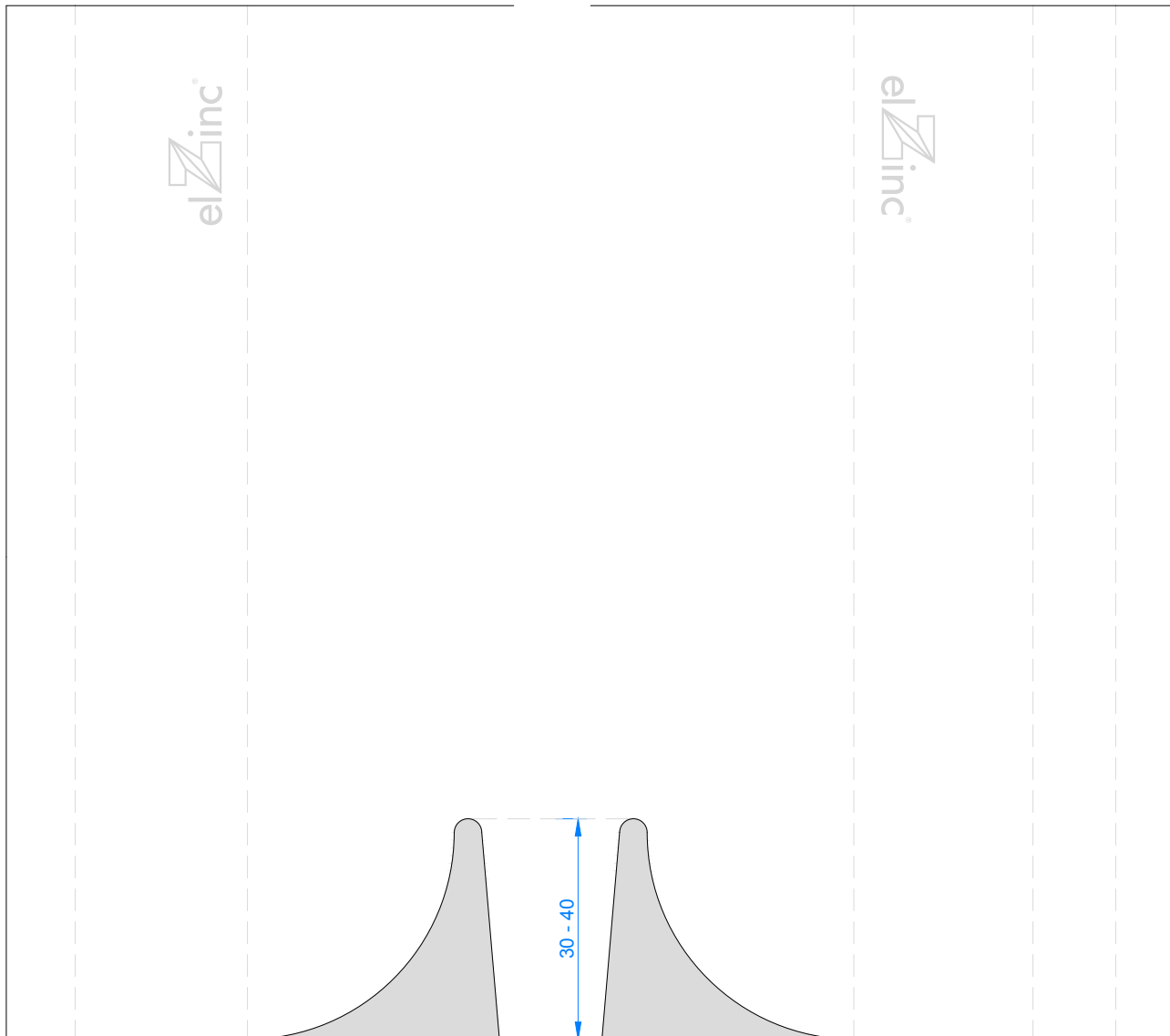

Scale 1/1

All dimensions are indicative unless specified on the drawing

- Use punch or 3mm diameter drill for rounded corner

Swabian foot - DLSS I 1.2.1.05

1/1

01

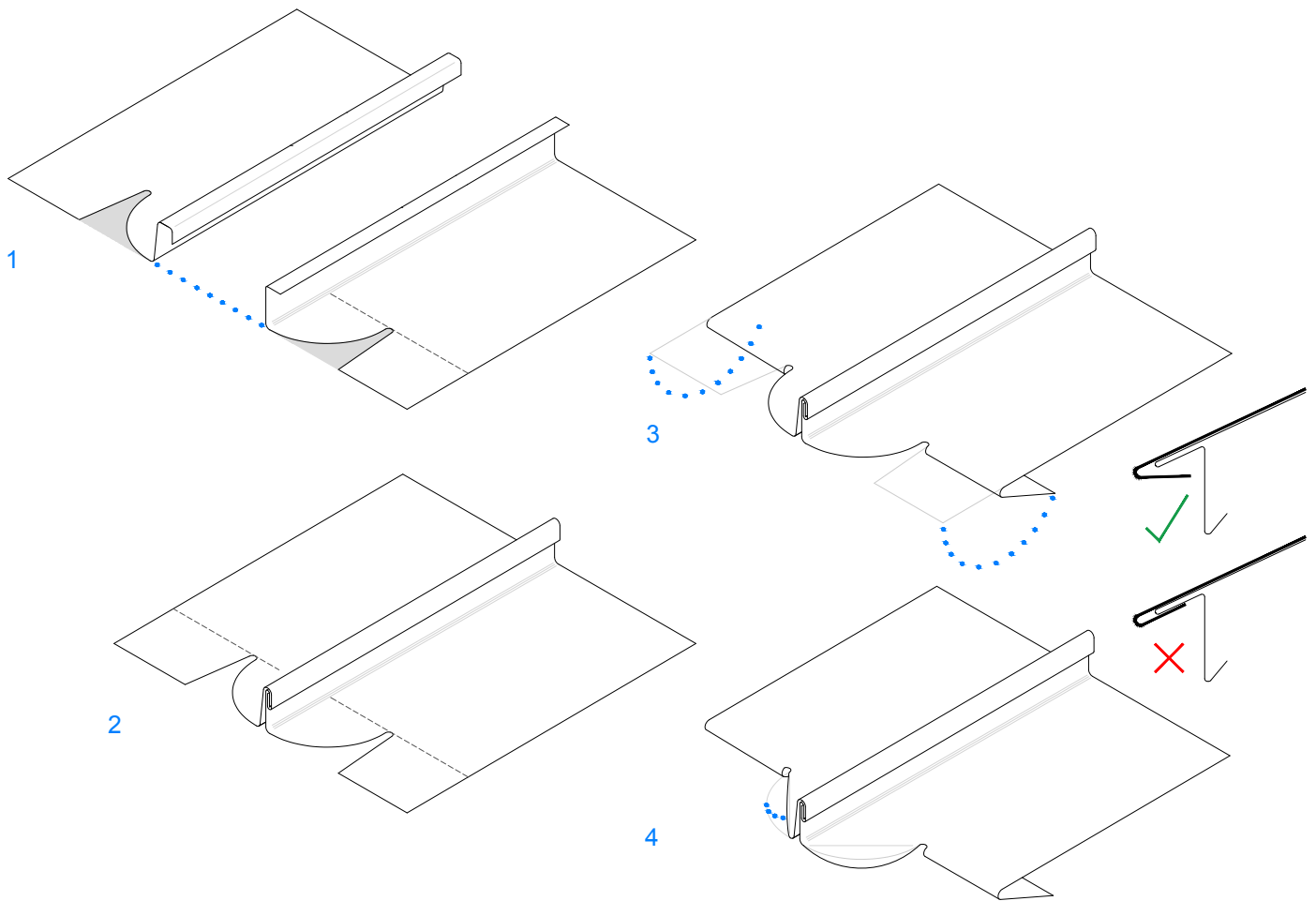

Scale 1/4

All dimensions are indicative unless specified on the drawing



Turned down upstand - DLSS I 1.2.1.03a

01

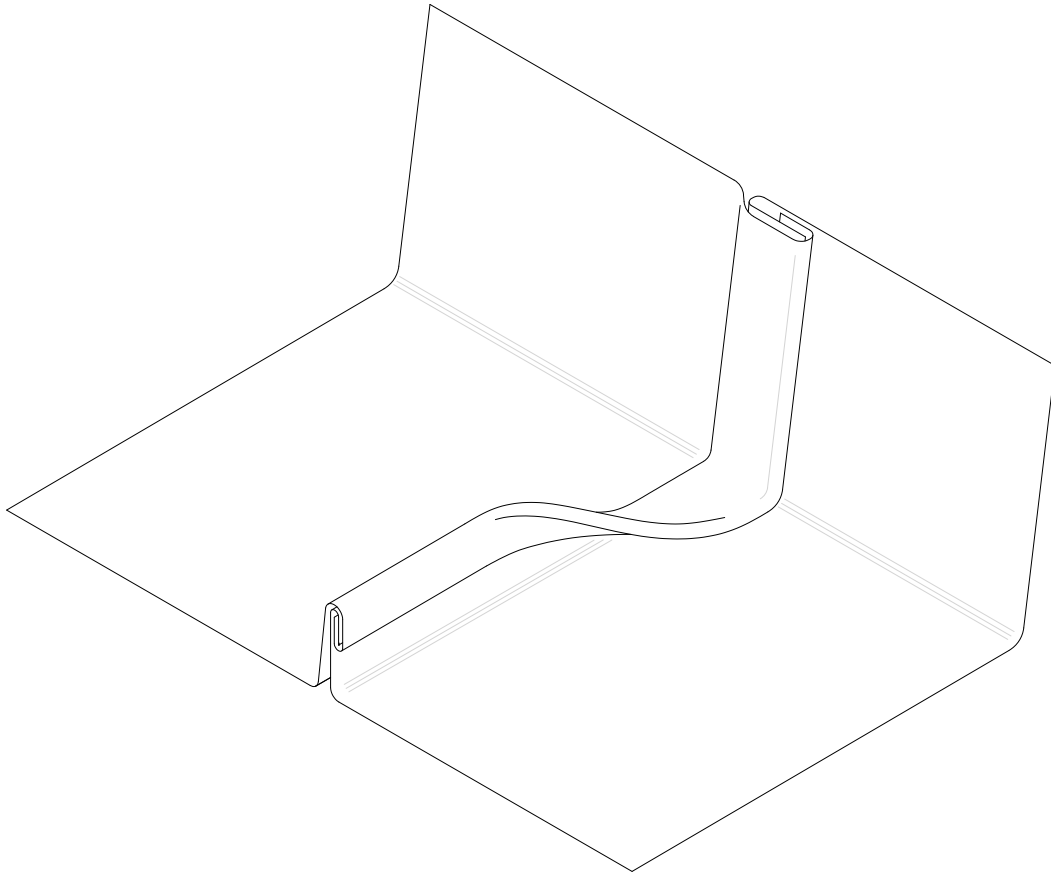

Scale 1/2

All dimensions are indicative unless specified on the drawing

- OK > 3°
- Used for short / medium upstands
- A space slightly greater than upstand height is needed behind detail

Turned down upstand - DLSS I 1.2.2.01

01



For correct printing, please make sure to set your printer to a 100% scale.

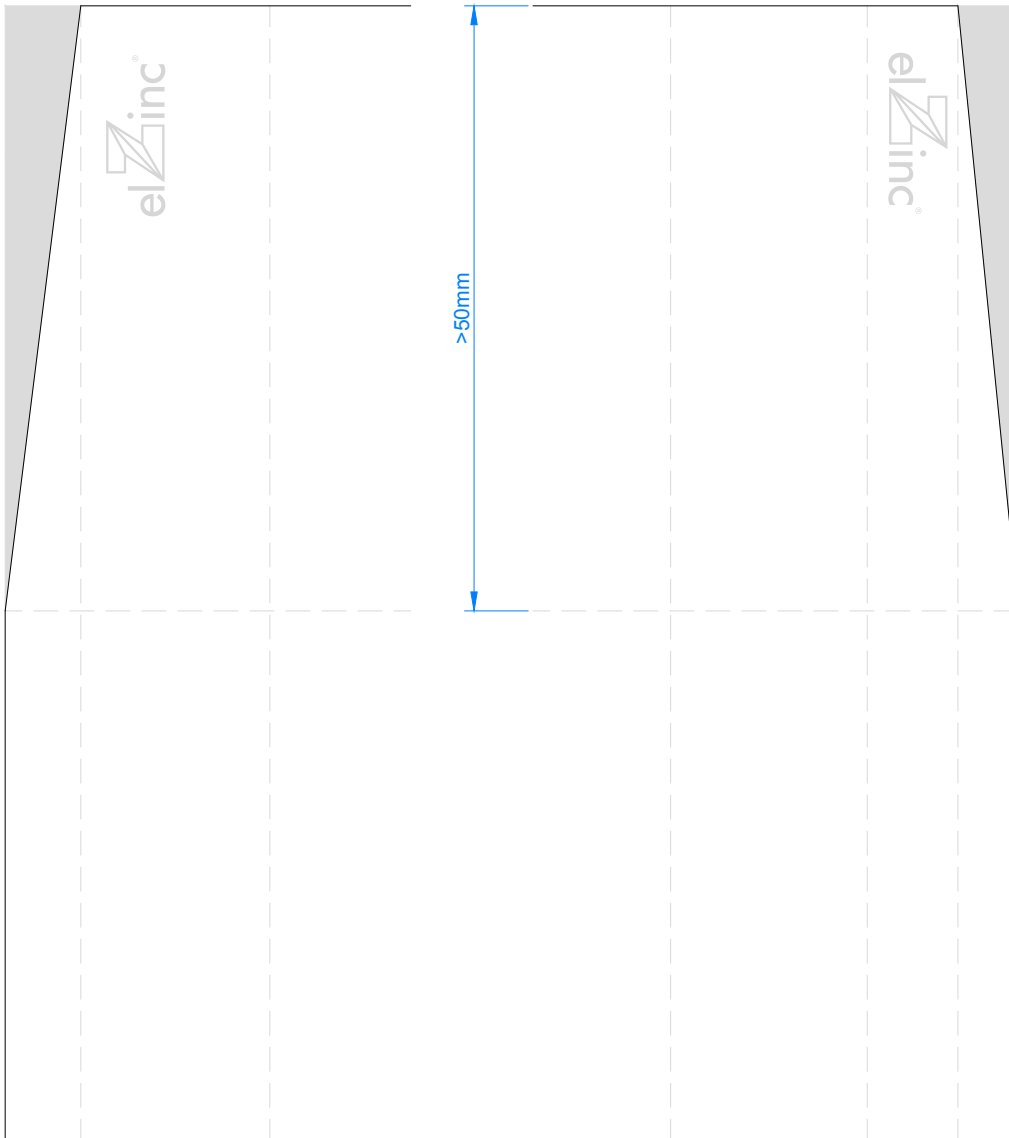

Turned down upstand - DLSS I 1.2.2.01

1/1

01

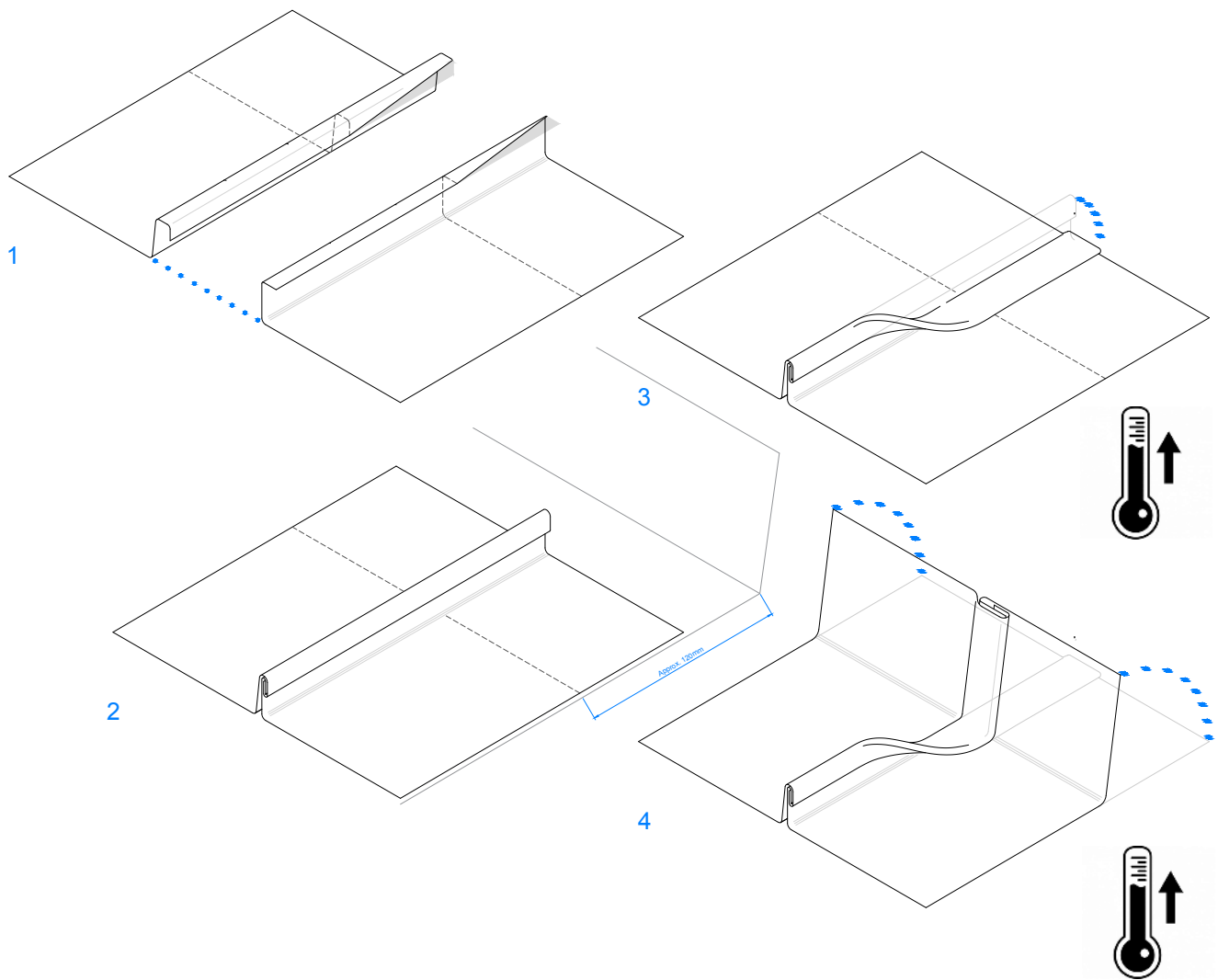

Scale 1/4

All dimensions are indicative unless specified on the drawing

· Step 3 & 4: Warm up in cold weather and fold upstand with generous radius



Straight dog-eared upstand - DLSS I 1.2.2.02a

01

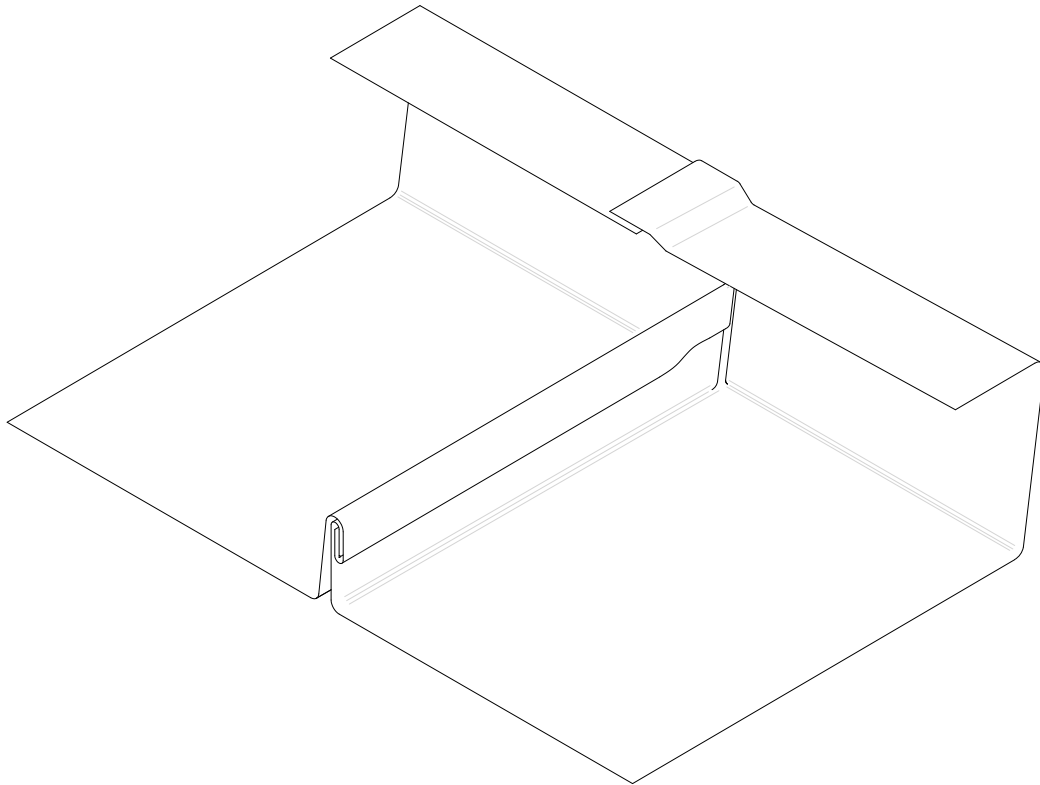

Scale 1/2

All dimensions are indicative unless specified on the drawing

- Used for short upstands
- A space slightly greater than upstand height is needed behind detail

Straight dog-eared upstand - DLSS I 1.2.2.02a

01

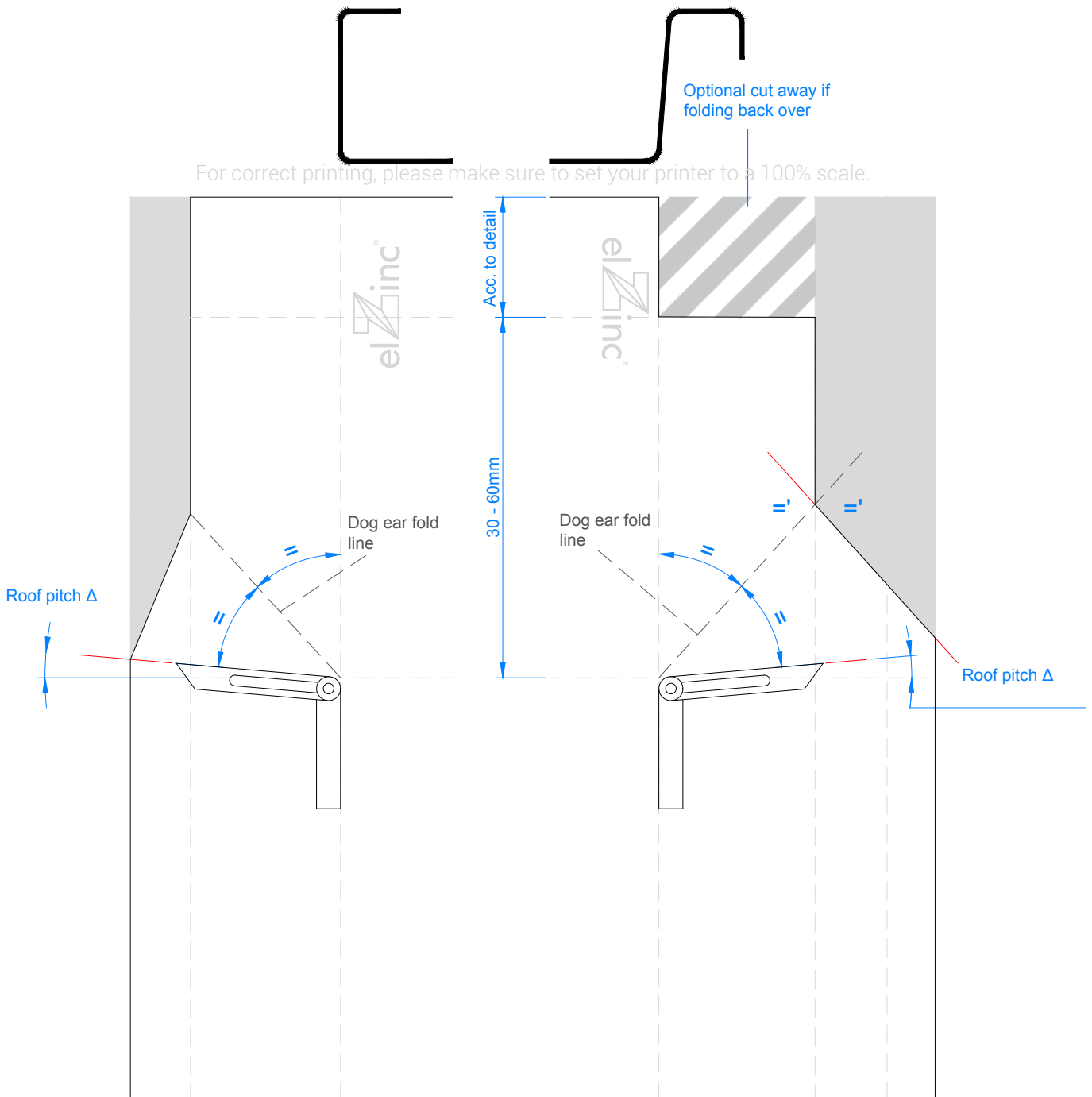

Straight dog-eared upstand - DLSS I 1.2.2.02a

1/3

01

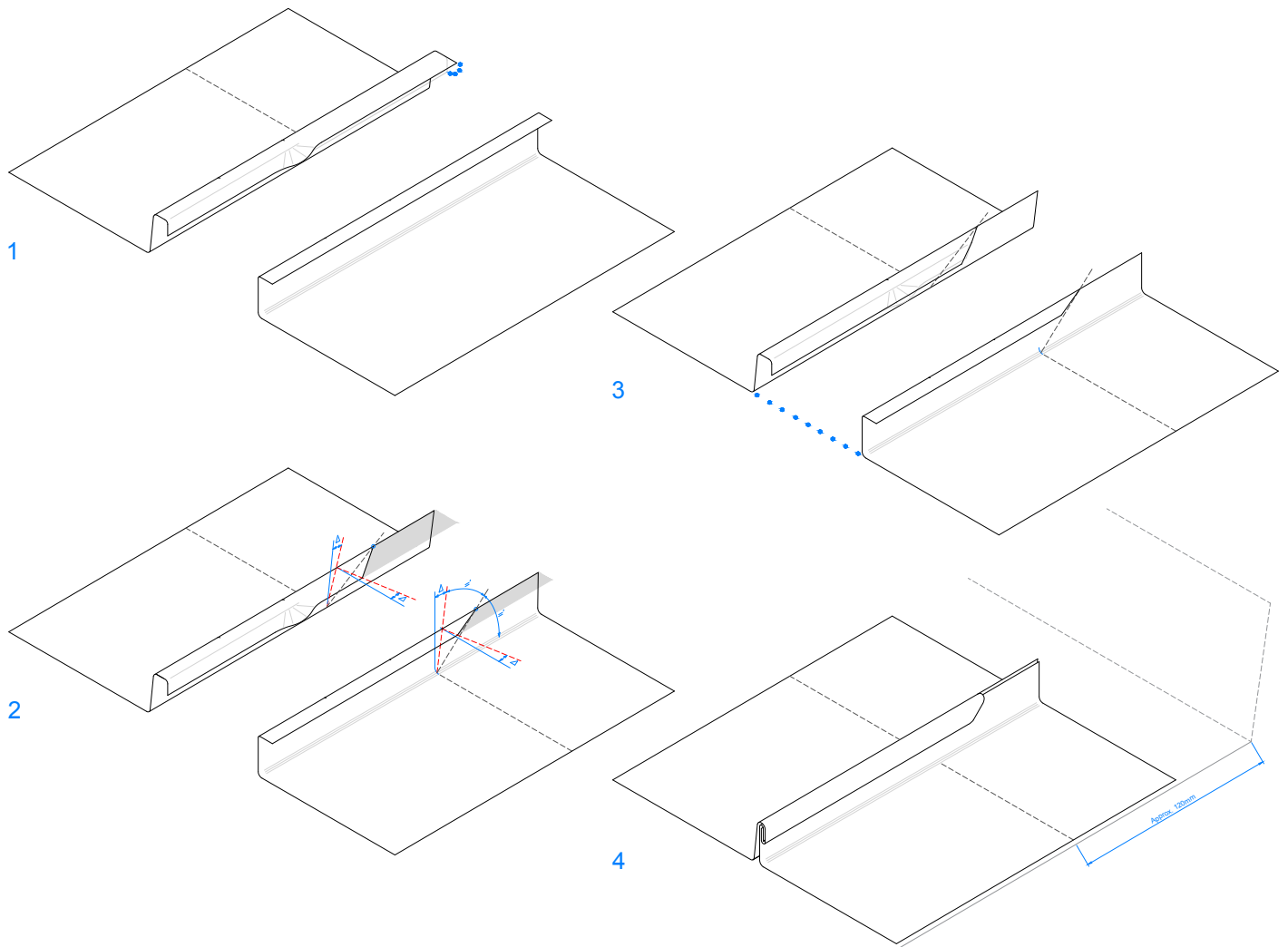

Scale 1/4

All dimensions are indicative unless specified on the drawing

Step 1



Step 2



Step 4



+

Straight dog-eared upstand - DLSS I 1.2.2.02a

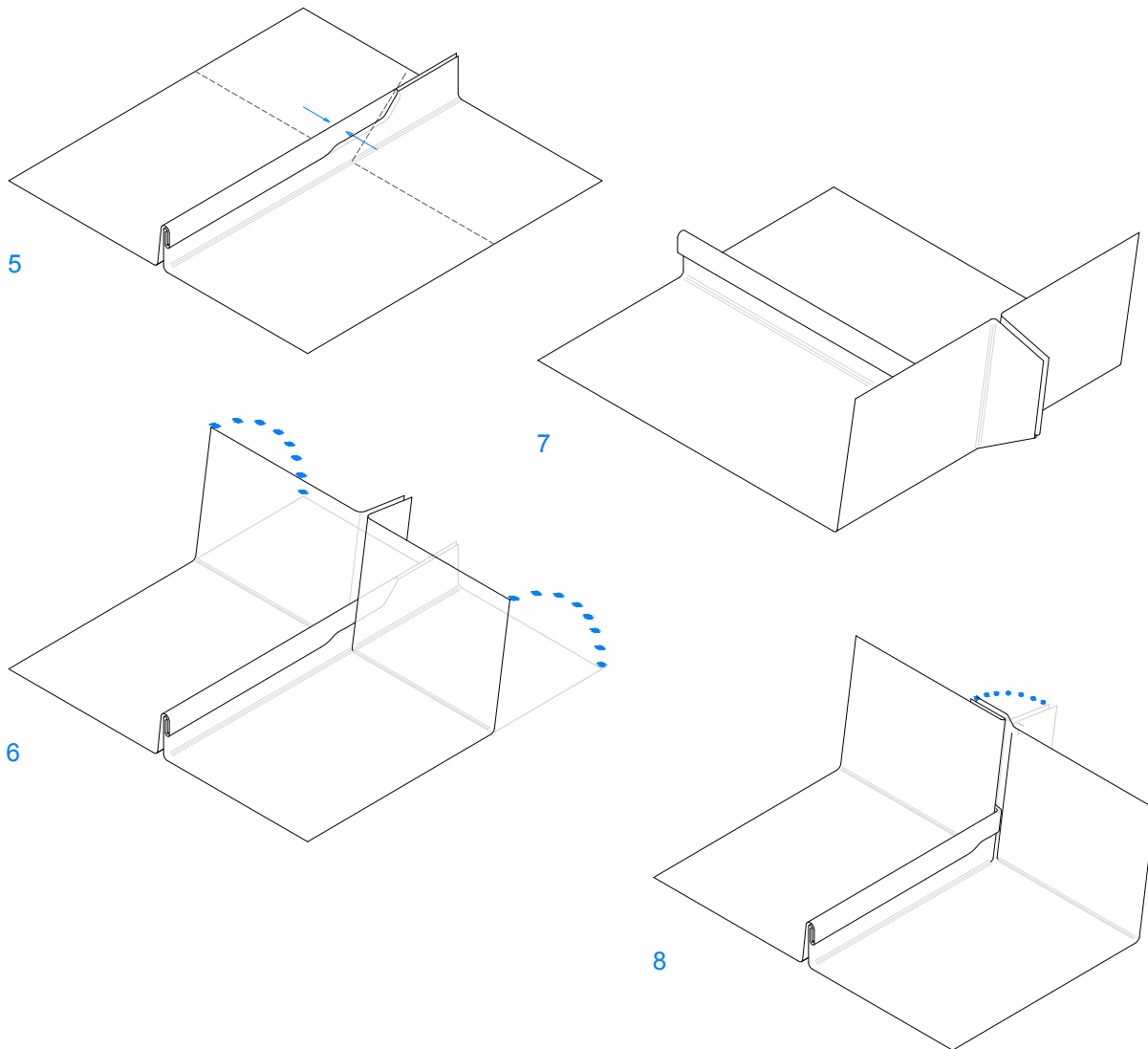

Scale 1/4

All dimensions are indicative unless specified on the drawing

Step 5



Step 6



Step 8



Straight dog-eared upstand - DLSS I 1.2.2.02a

3/3

01

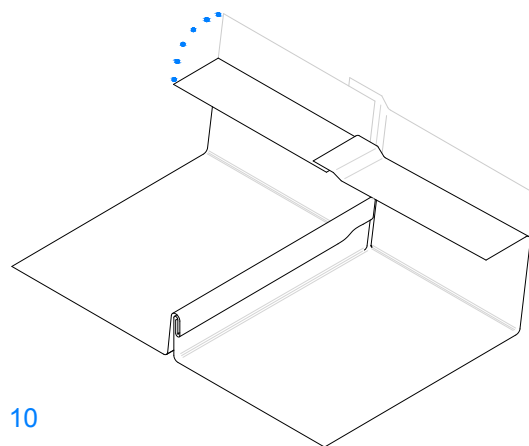
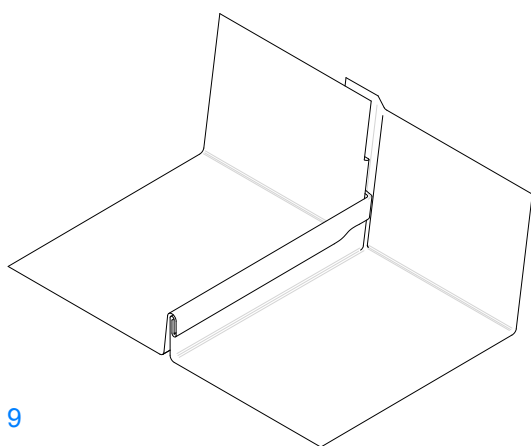

Scale 1/4

All dimensions are indicative unless specified on the drawing

Step 9



Preformed straight dog-eared upstand - DLSS I 1.2.2.02b

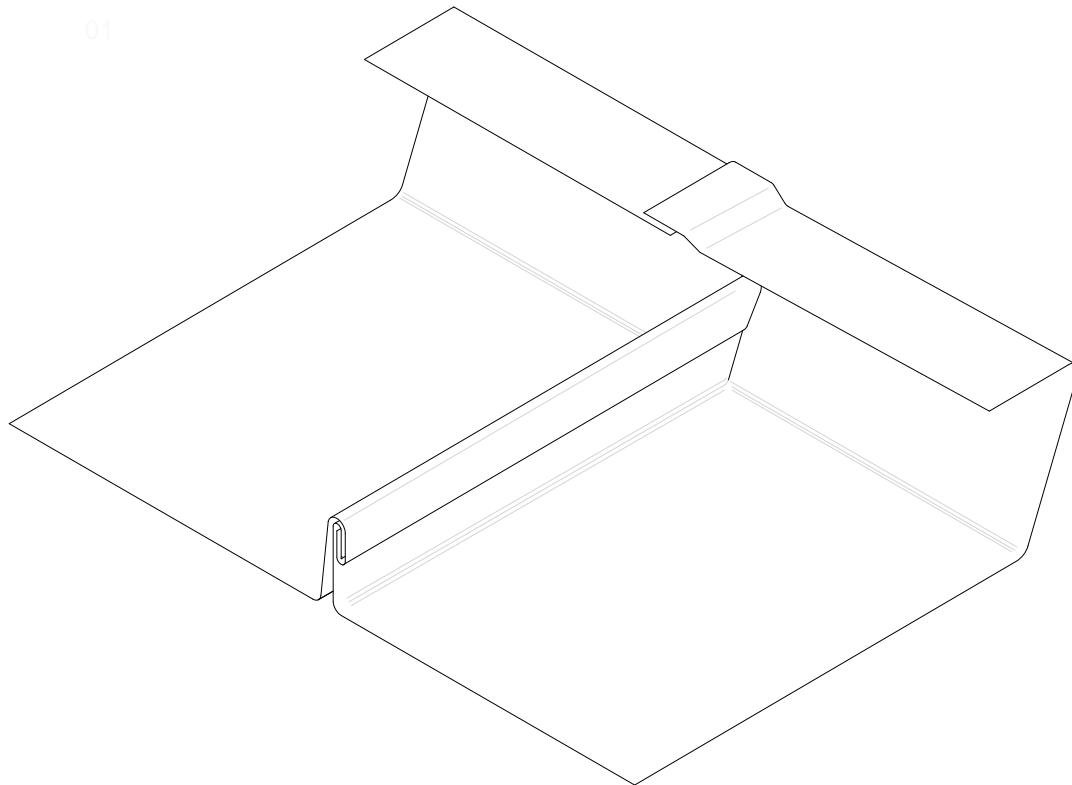

Scale 1/2

All dimensions are indicative unless specified on the drawing

- OK >25°
- Used for short upstands

Preformed straight dog-eared upstand - DLSS I 1.2.2.02b

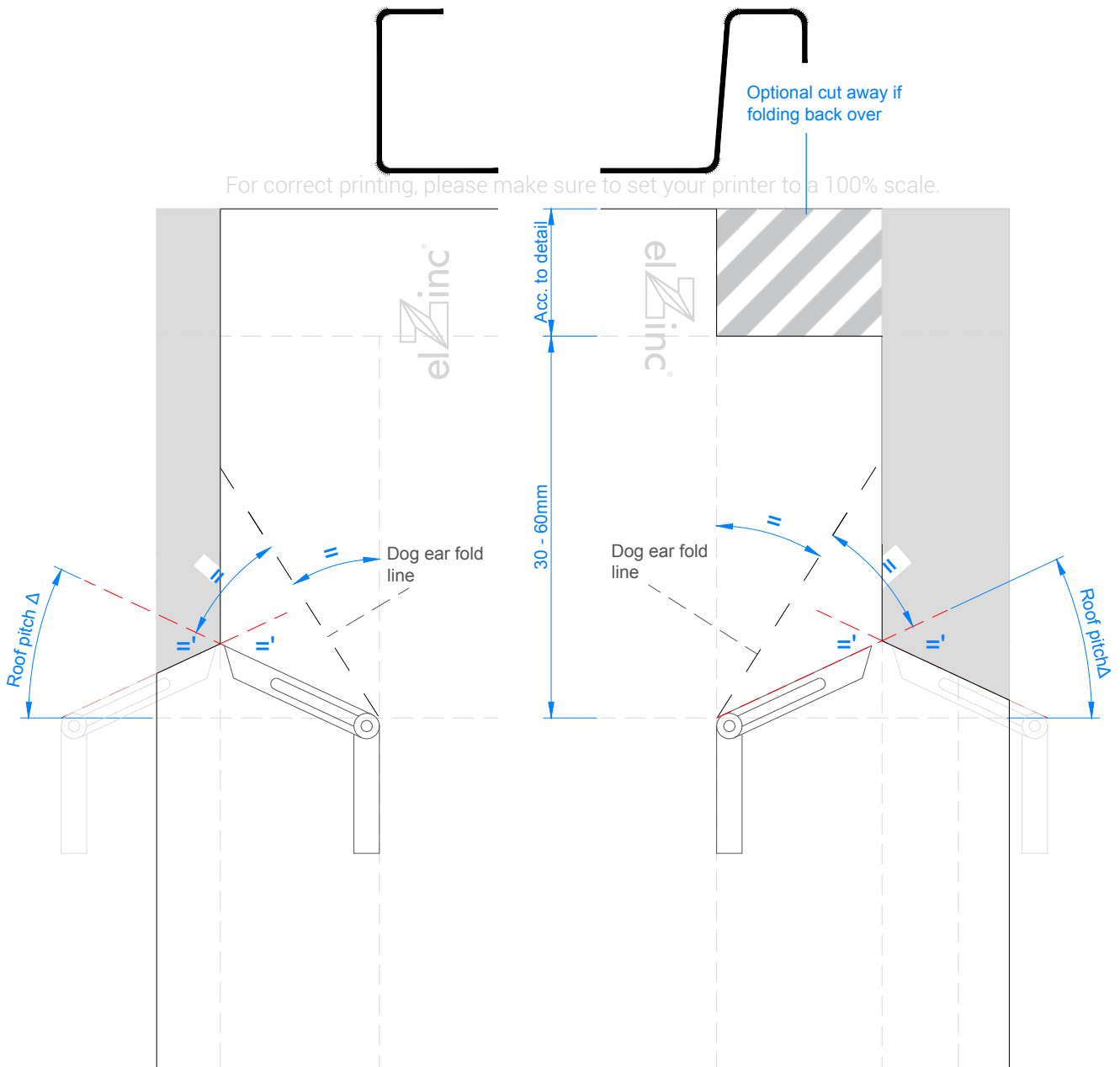

Scale 1/1

All dimensions are indicative unless specified on the drawing

- Generally limited to steeply pitched roofs
- Used for short upstands

Preformed straight dog-eared upstand - DLSS I 1.2.2.02b 1/3

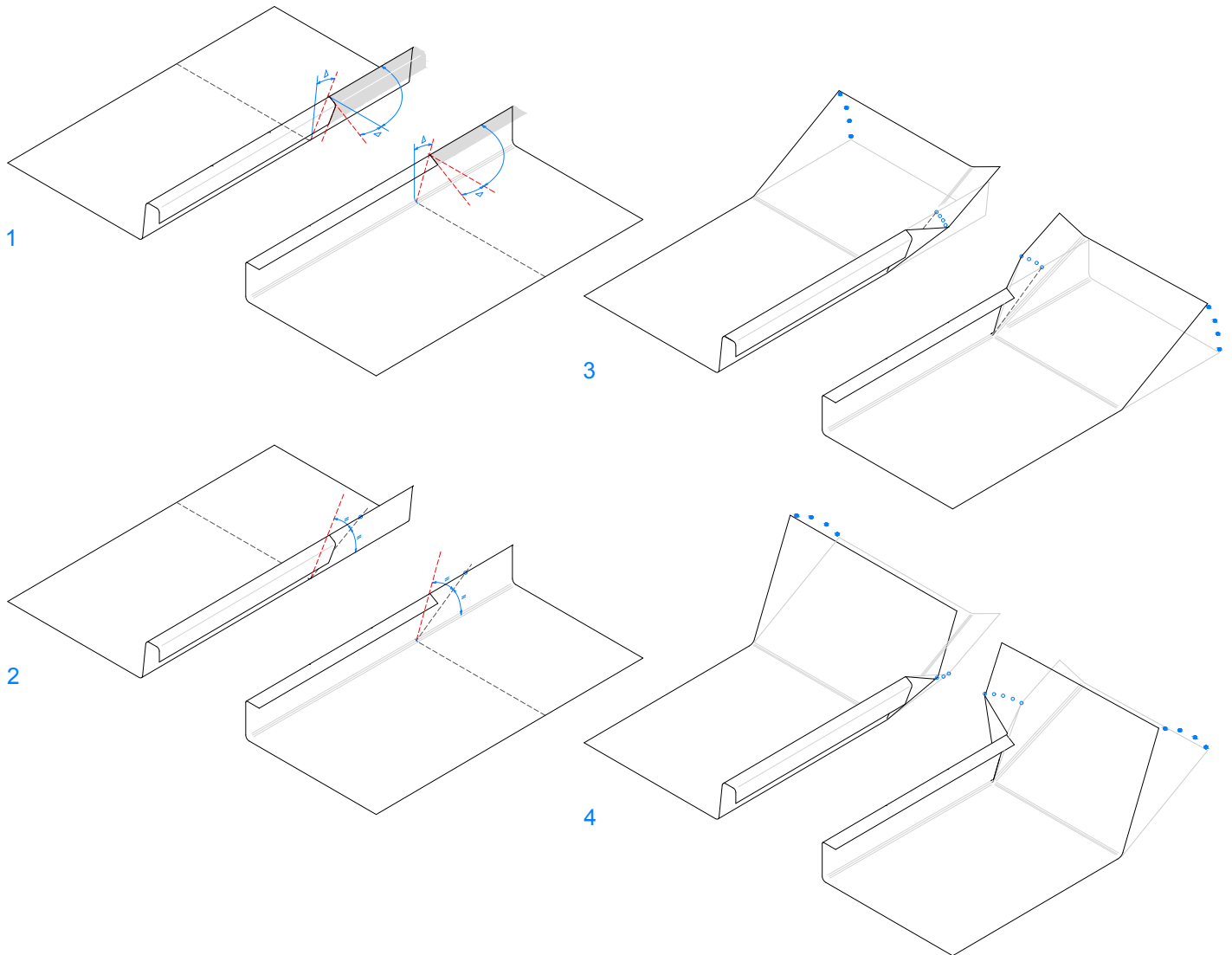

Scale 1/4

All dimensions are indicative unless specified on the drawing

· A seaming iron or seaming pliers can be used to fold to bend upstand (seaming iron shown)



Preformed straight dog-eared upstand - DLSS I 1.2.2.02b 2/3

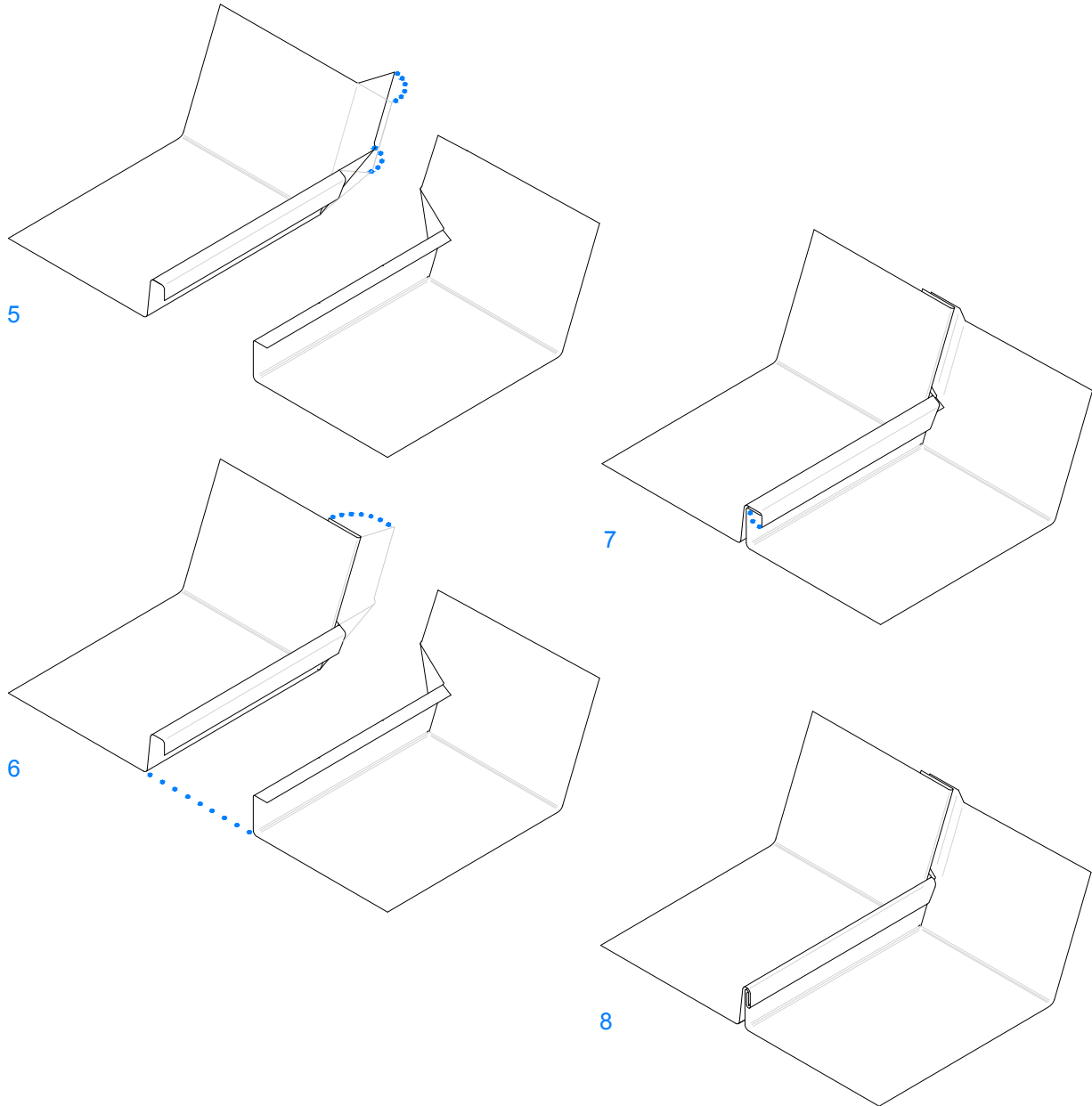

Scale 1/4

All dimensions are indicative unless specified on the drawing



Preformed straight dog-eared upstand - DLSS I 1.2.2.02b 3/3

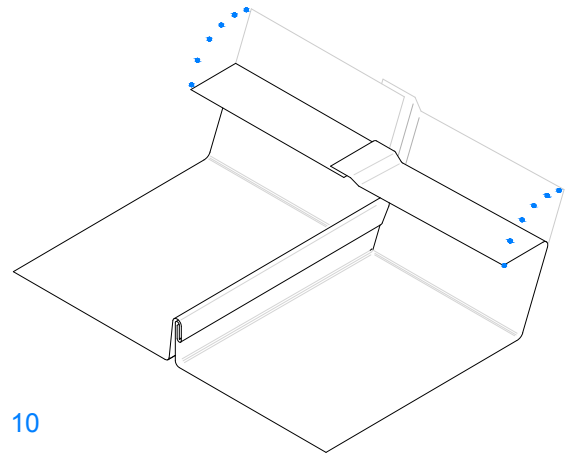
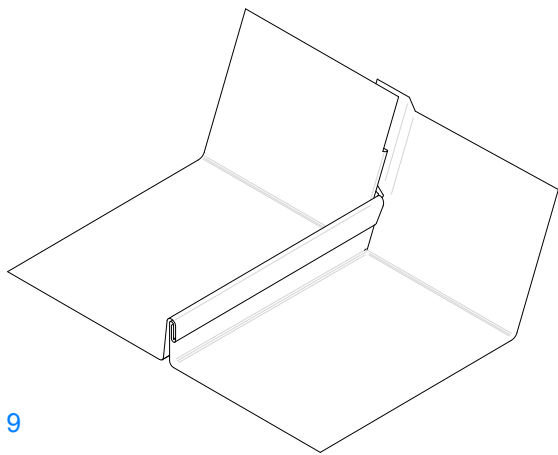

Scale 1/4

All dimensions are indicative unless specified on the drawing

Step 10



Pinched seam - DLSS I 1.2.2.03a

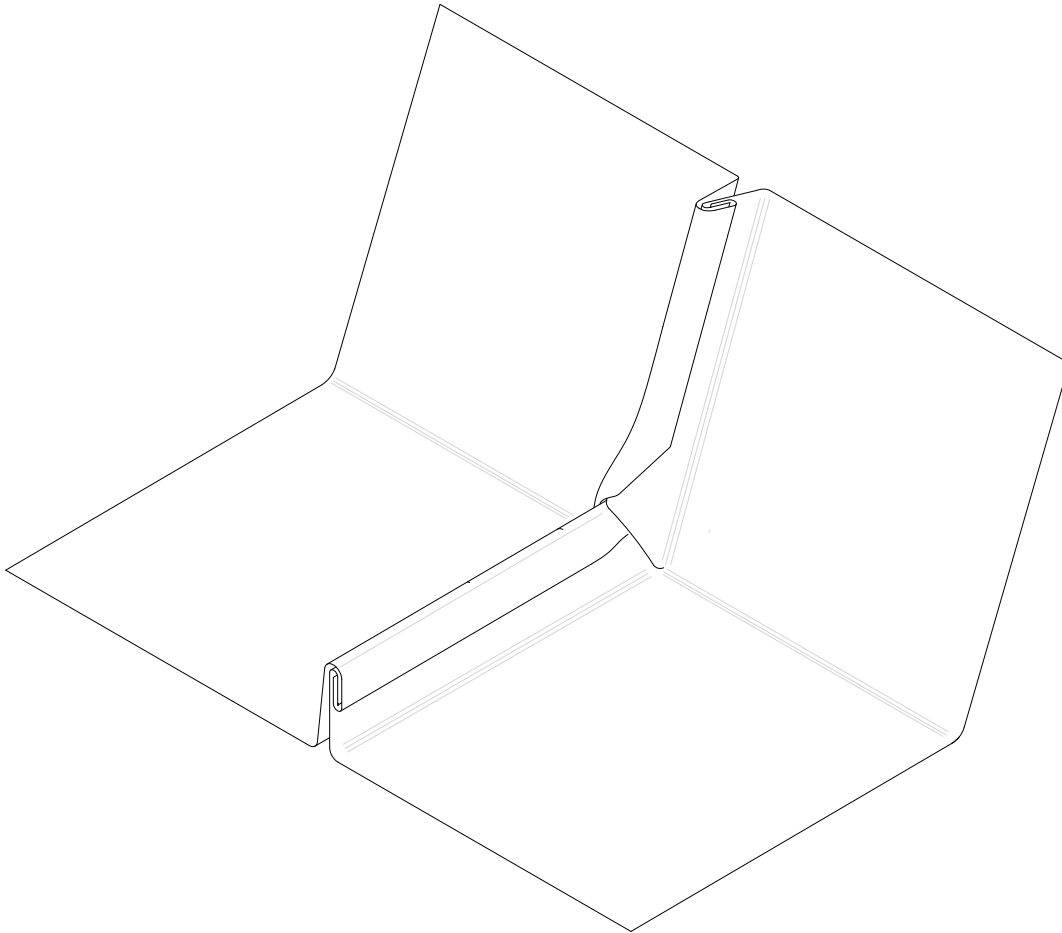

Scale 1/2

All dimensions are indicative unless specified on the drawing

- OK > 3°
- Preferred method for tall upstands

Pinched seam - DLSS I 1.2.2.03a



For correct printing, please make sure to set your printer to a 100% scale.

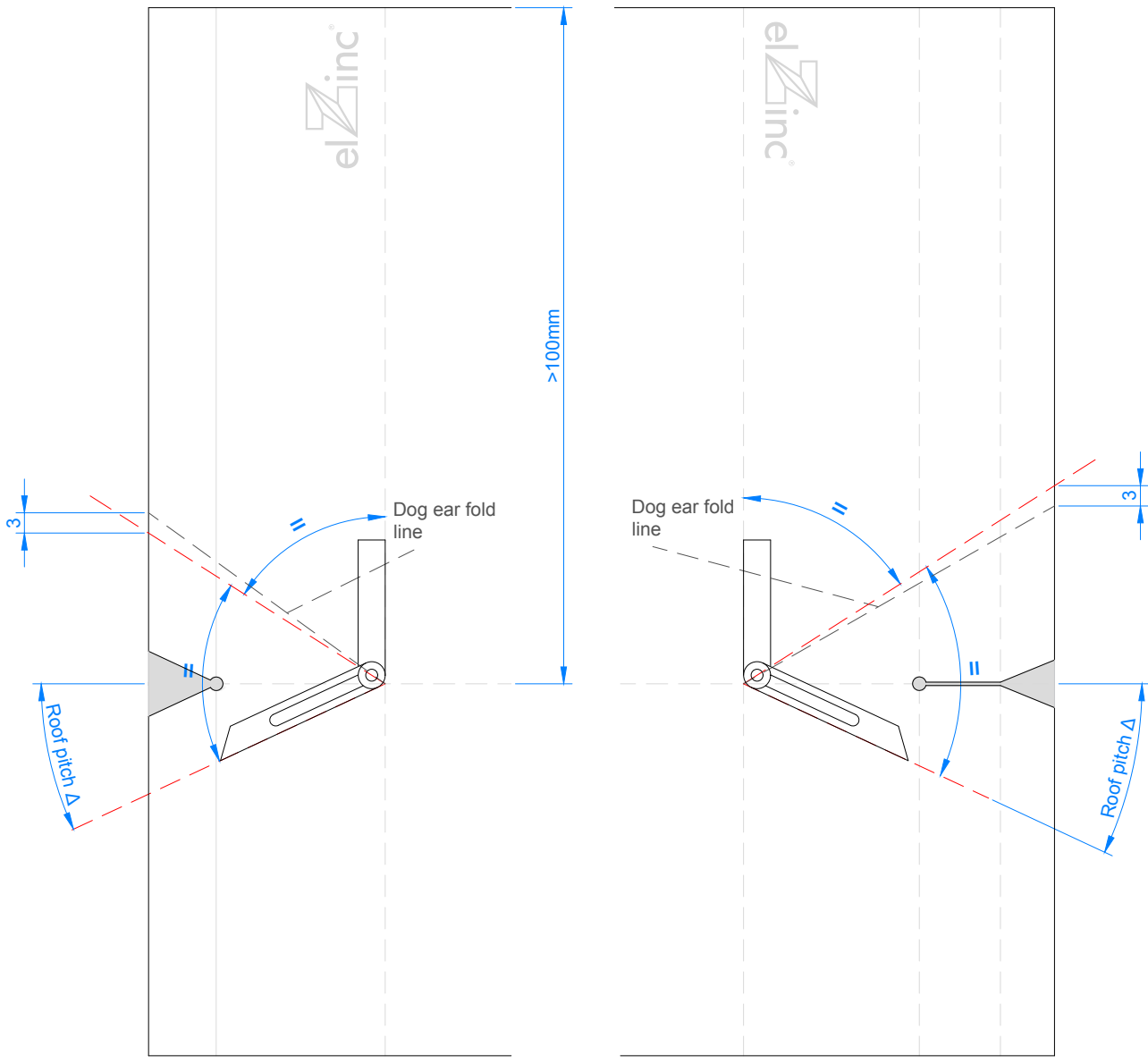

Scale 1/2

All dimensions are indicative unless specified on the drawing

- OK > 3°
- Preferred method for tall upstands

Pinched seam - DLSS I 1.2.2.03a

1/3

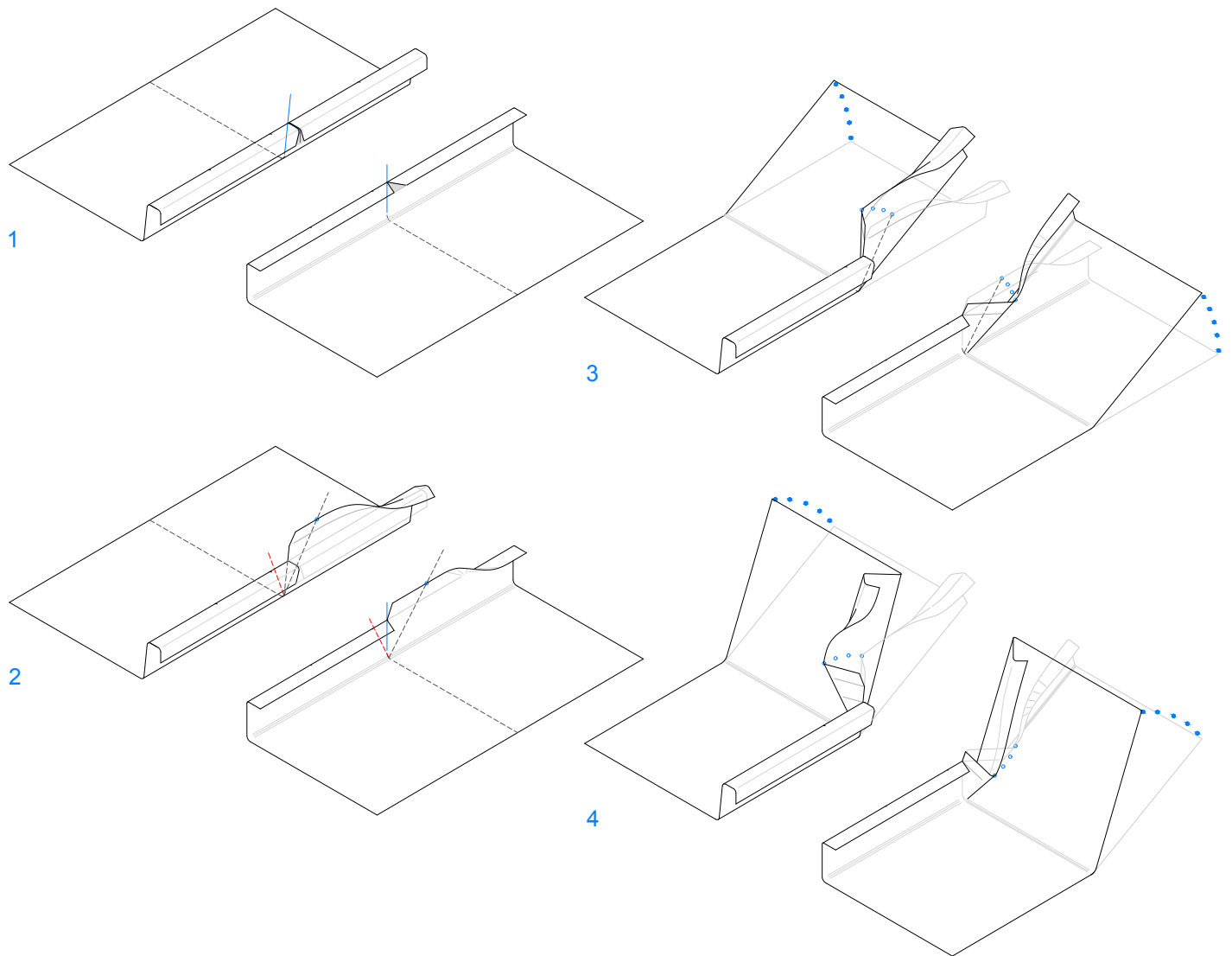

Scale 1/4

All dimensions are indicative unless specified on the drawing

· Hold flat head seaming iron against upstand fold line and bend up by pushing from back

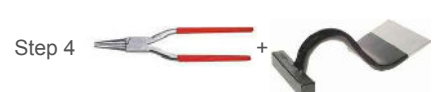

Pinched seam - DLSS I 1.2.2.03a

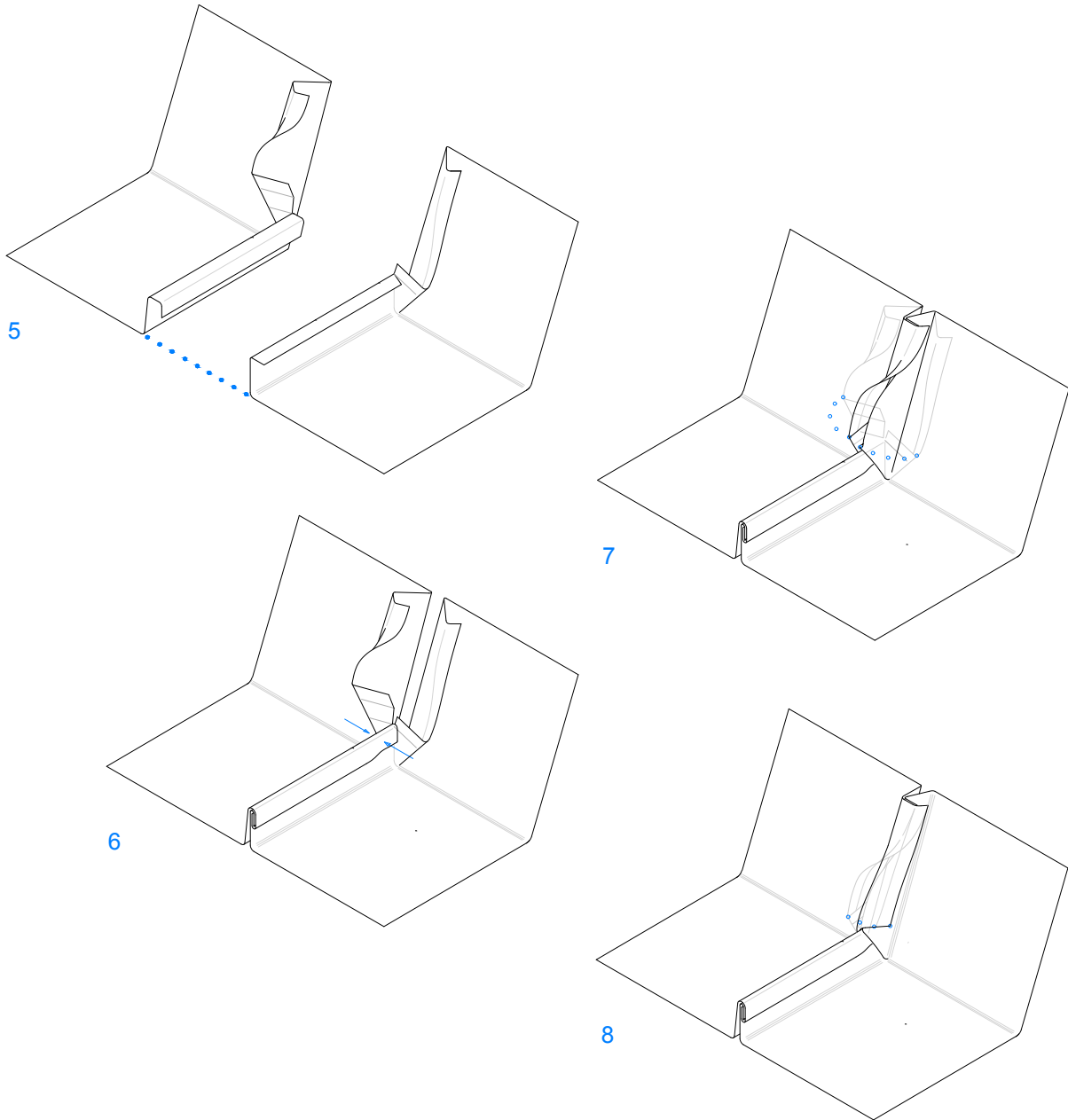

Scale 1/4

All dimensions are indicative unless specified on the drawing

- Step 7: Overcloak dog-ear fold must be slightly lower than undercloak
- Step 8: Overcloak folds must wrap over and cover undercloak 'hole'

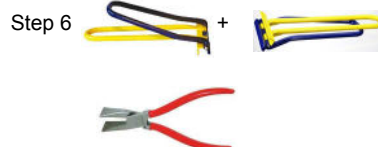

Pinched seam - DLSS I 1.2.2.03a

3/3

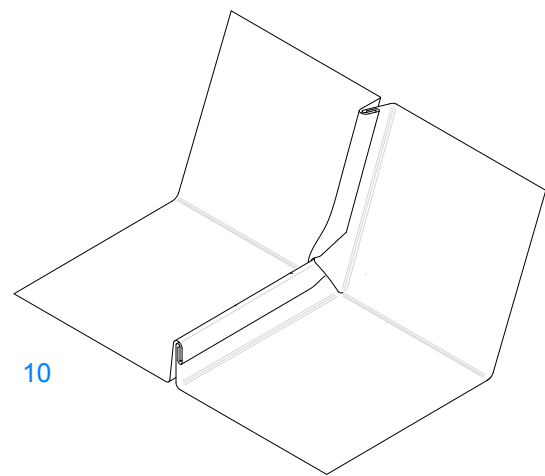
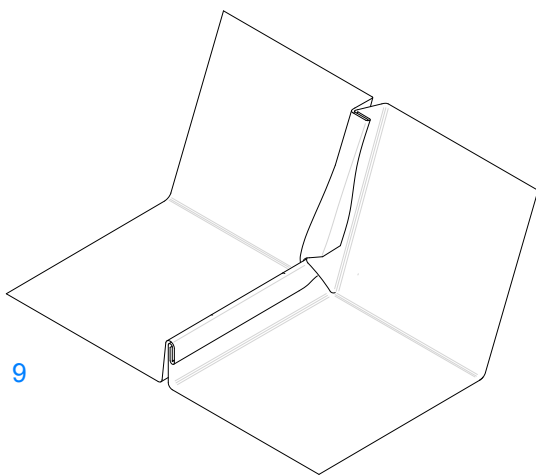

Scale 1/4

All dimensions are indicative unless specified on the drawing

Step 9



Step 10



Saddled pinched seam - DLSS I 1.2.2.03b

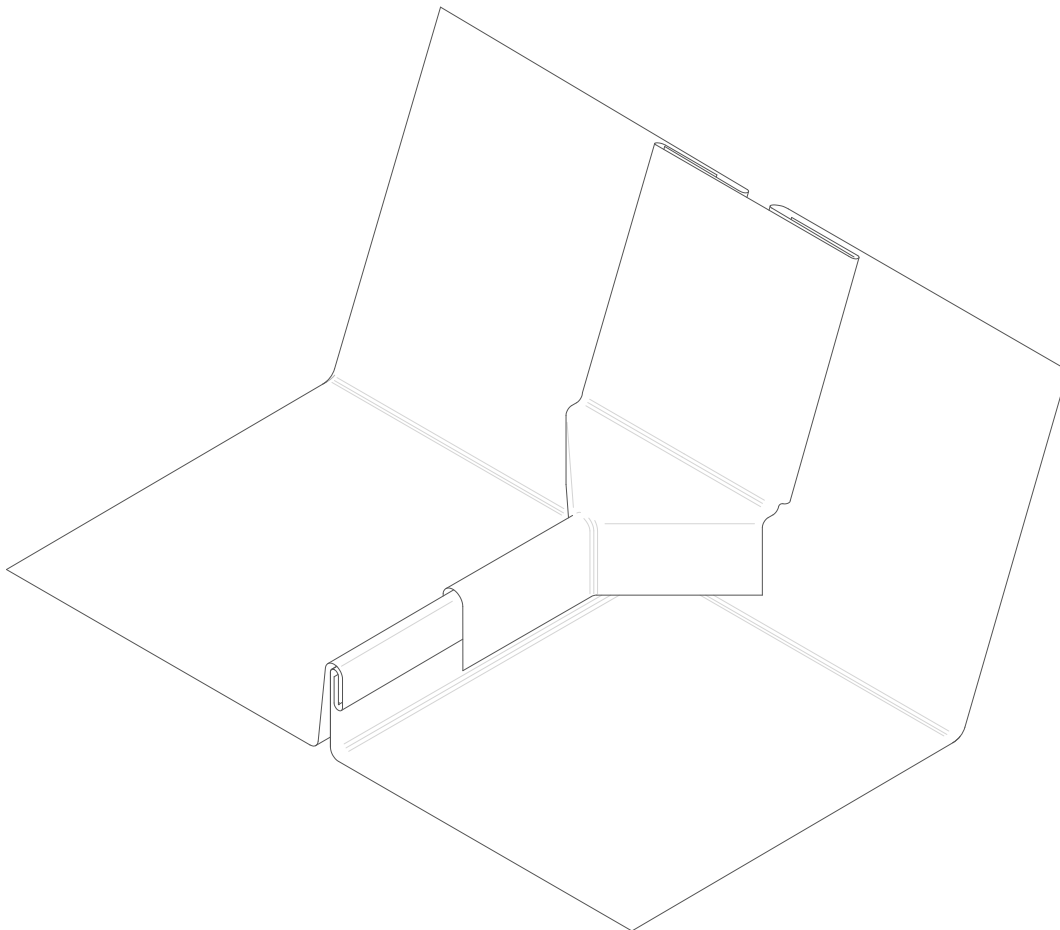

Scale 1/2

All dimensions are indicative unless specified on the drawing

· OK > 3°

Saddled pinched seam - DLSS I 1.2.2.03b



For correct printing, please make sure to set your printer to a 100% scale.

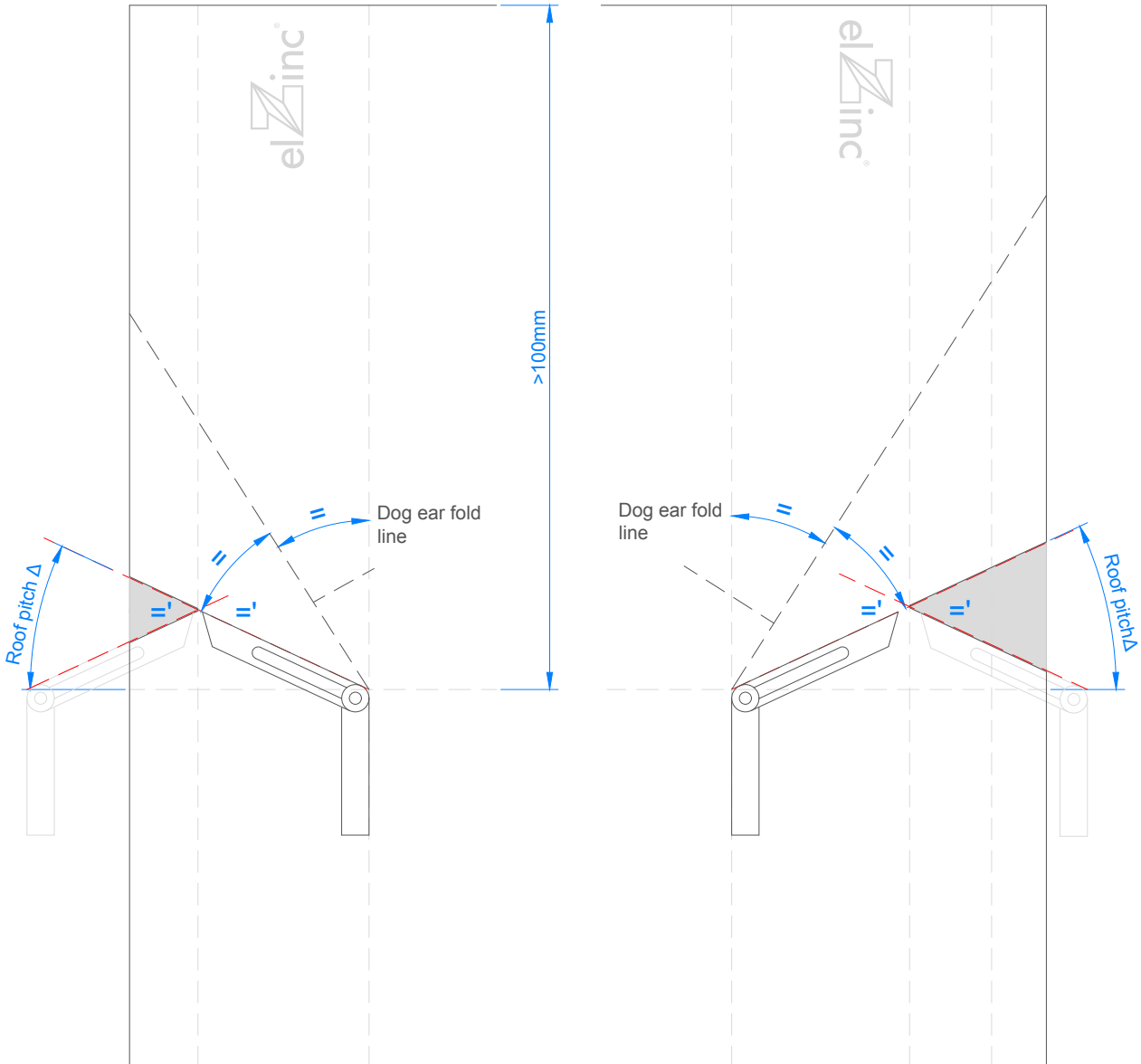

Scale 1/1

All dimensions are indicative unless specified on the drawing

· OK > 3°

Saddled pinched seam - DLSS I 1.2.2.03b

1/2

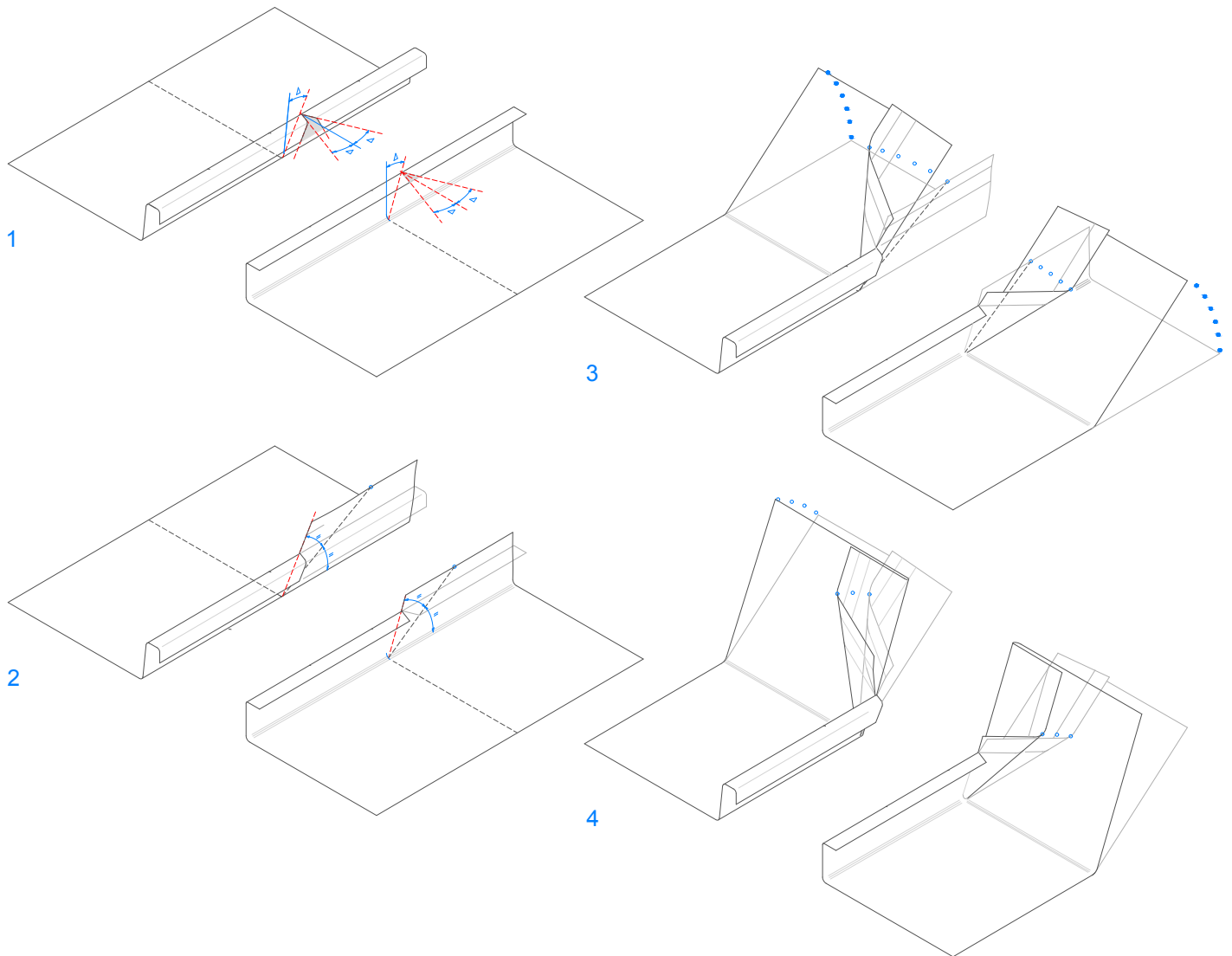

Scale 1/4

All dimensions are indicative unless specified on the drawing

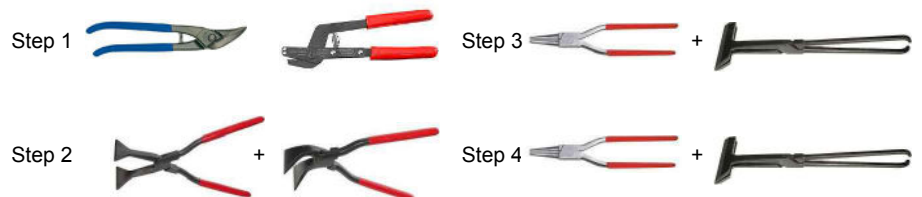

Saddled pinched seam - DLSS I 1.2.2.03b

2/2

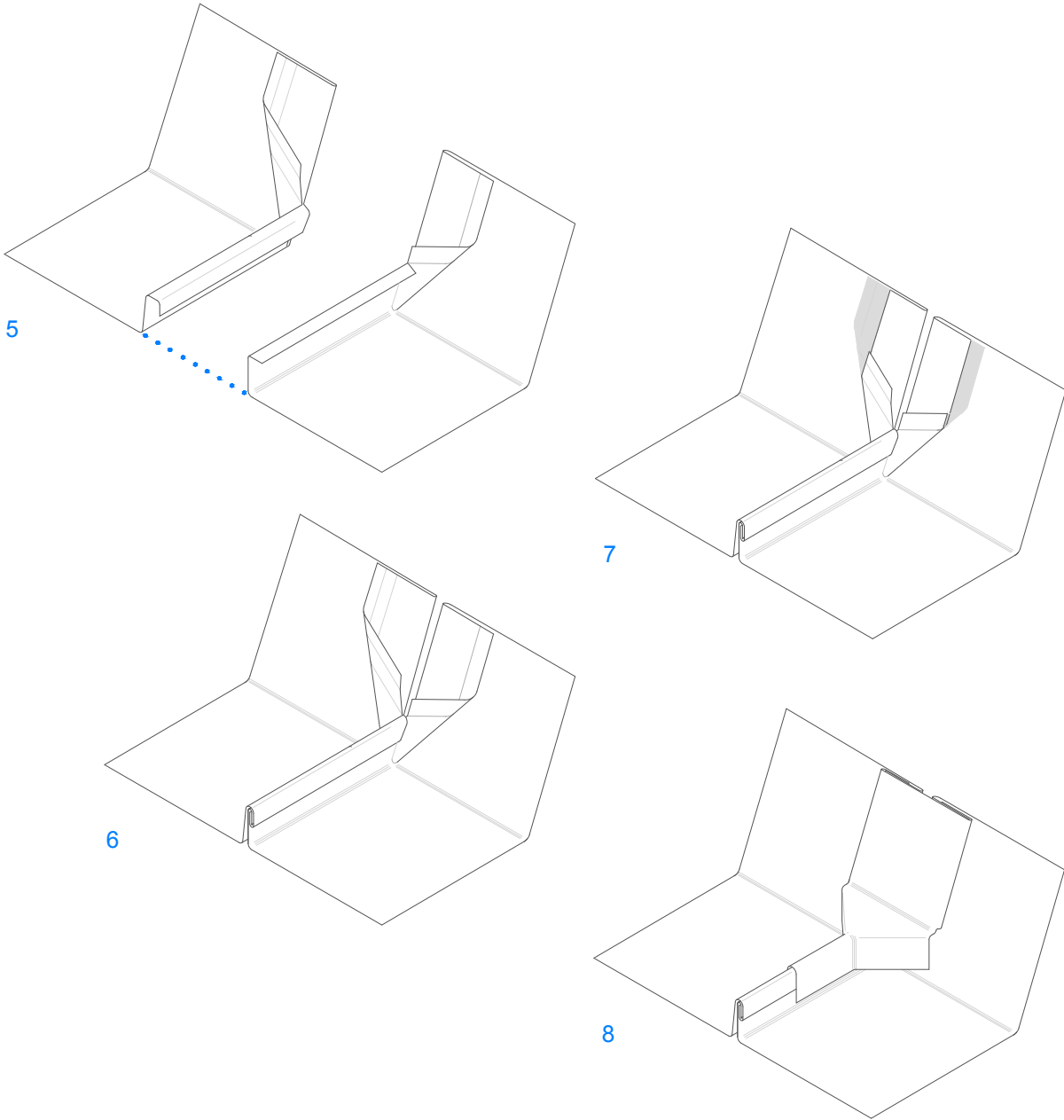

Scale 1/4

All dimensions are indicative unless specified on the drawing



Single lock cross welt - DLSS I 1.2.1.01a

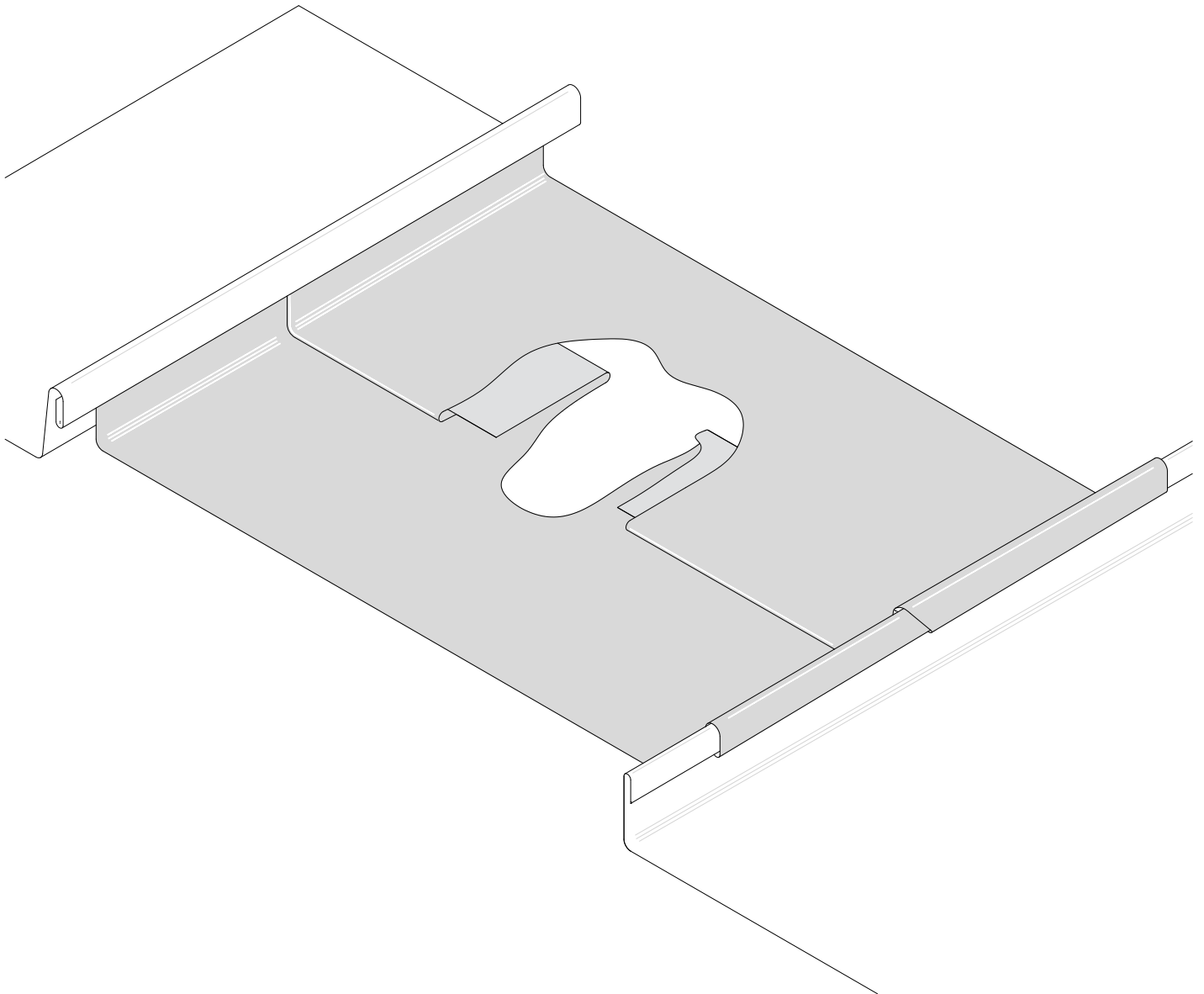

Scale 1/2

All dimensions are indicative unless specified on the drawing

· OK > 3°

Single lock cross welt - DLSS I 2.1.1a



For correct printing, please make sure to set your printer to a 100% scale.

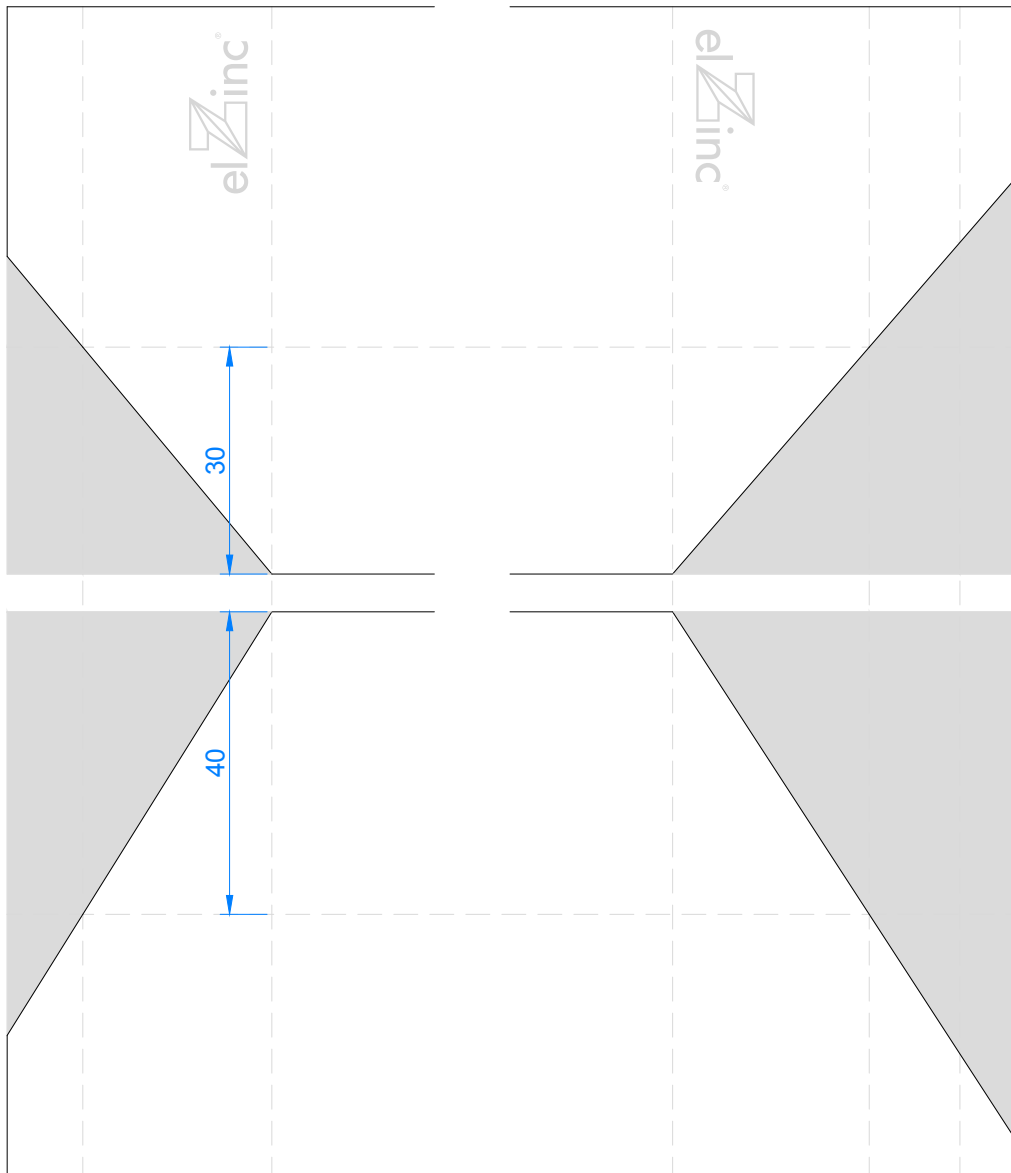

Single lock cross welt - DLSS I 2.1.1a

1/3

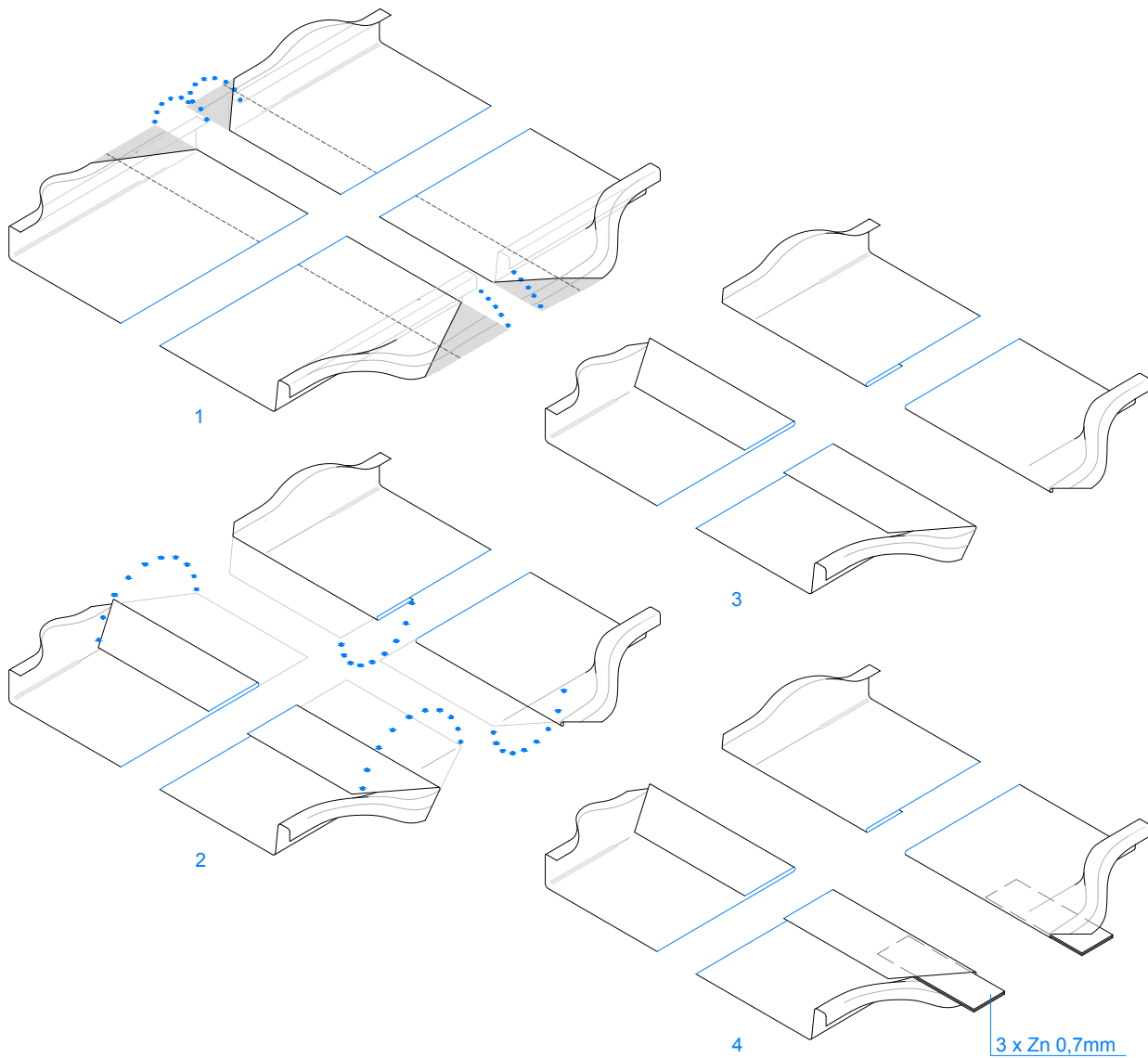

Scale 1/4

All dimensions are indicative unless specified on the drawing

· Step 2 preferably using folder



Single lock cross welt - DLSS I 2.1.1a

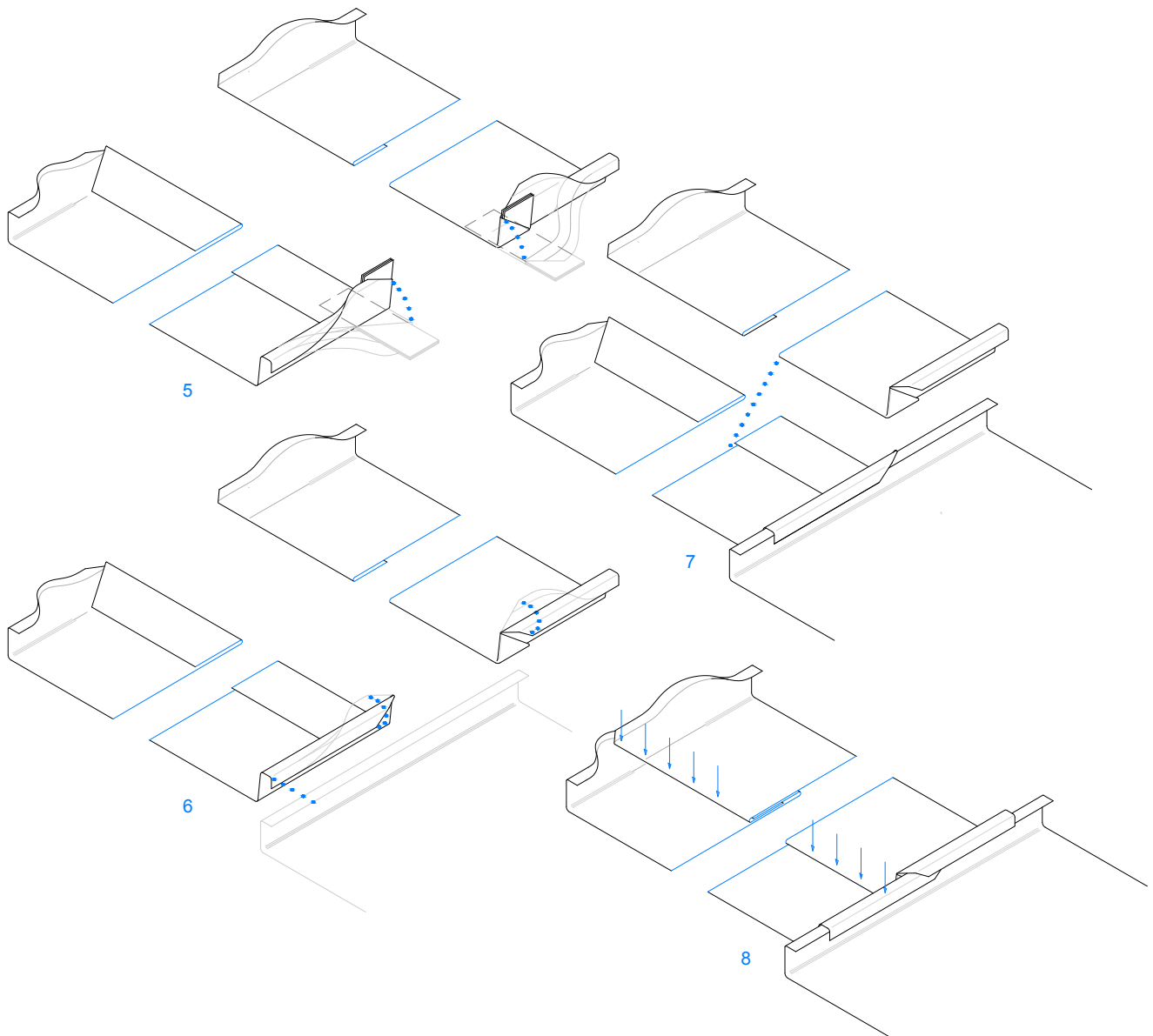

Scale 1/4

All dimensions are indicative unless specified on the drawing

· Step 5: Over-bend upstand then bend back to remove the 3 zinc spacers easily



Single lock cross welt - DLSS I 2.1.1a

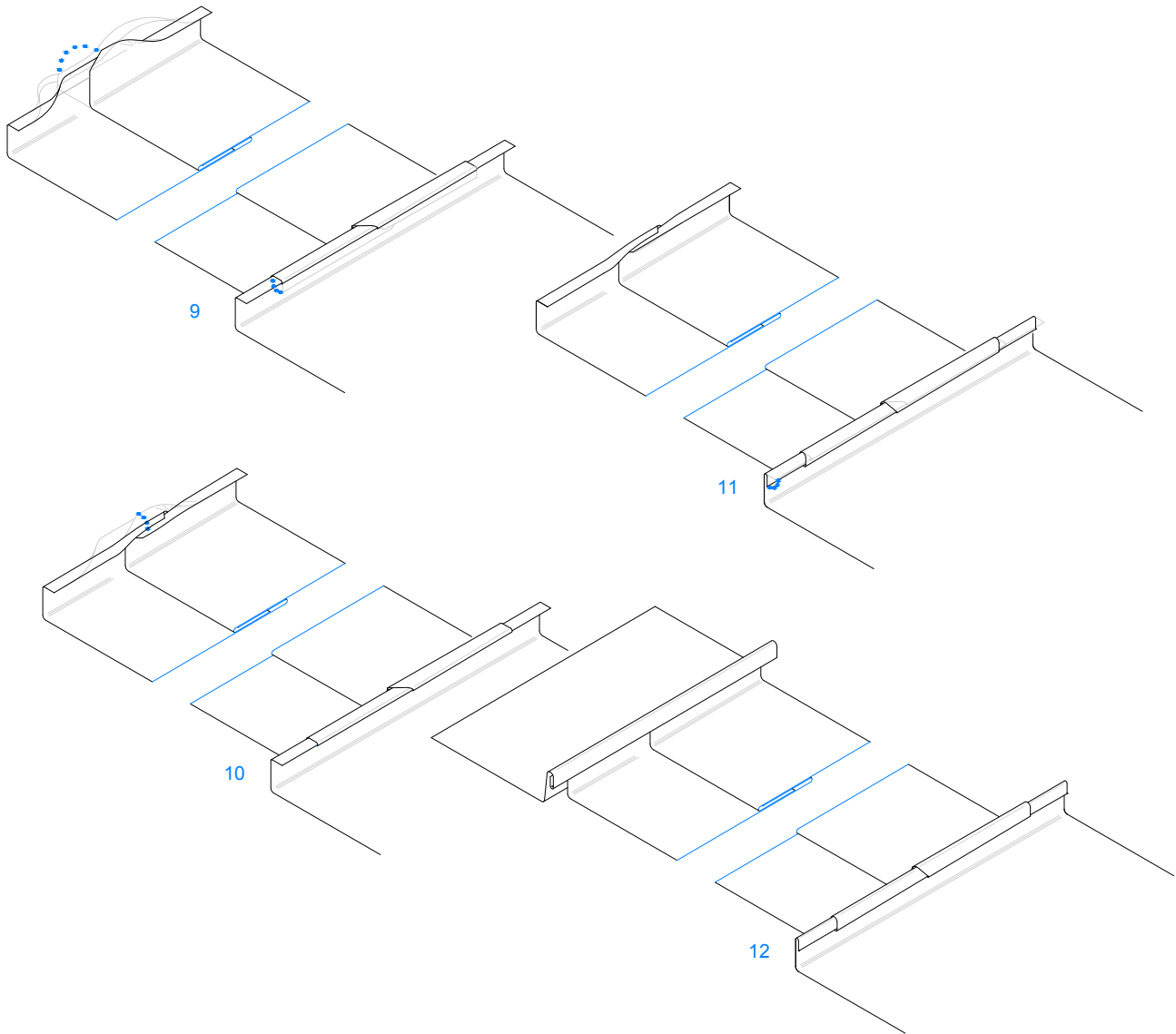

Scale 1/4

All dimensions are indicative unless specified on the drawing

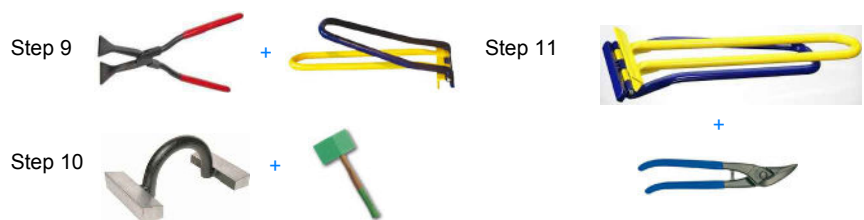

Single lock cross welt - DLSS I 2.1.1b

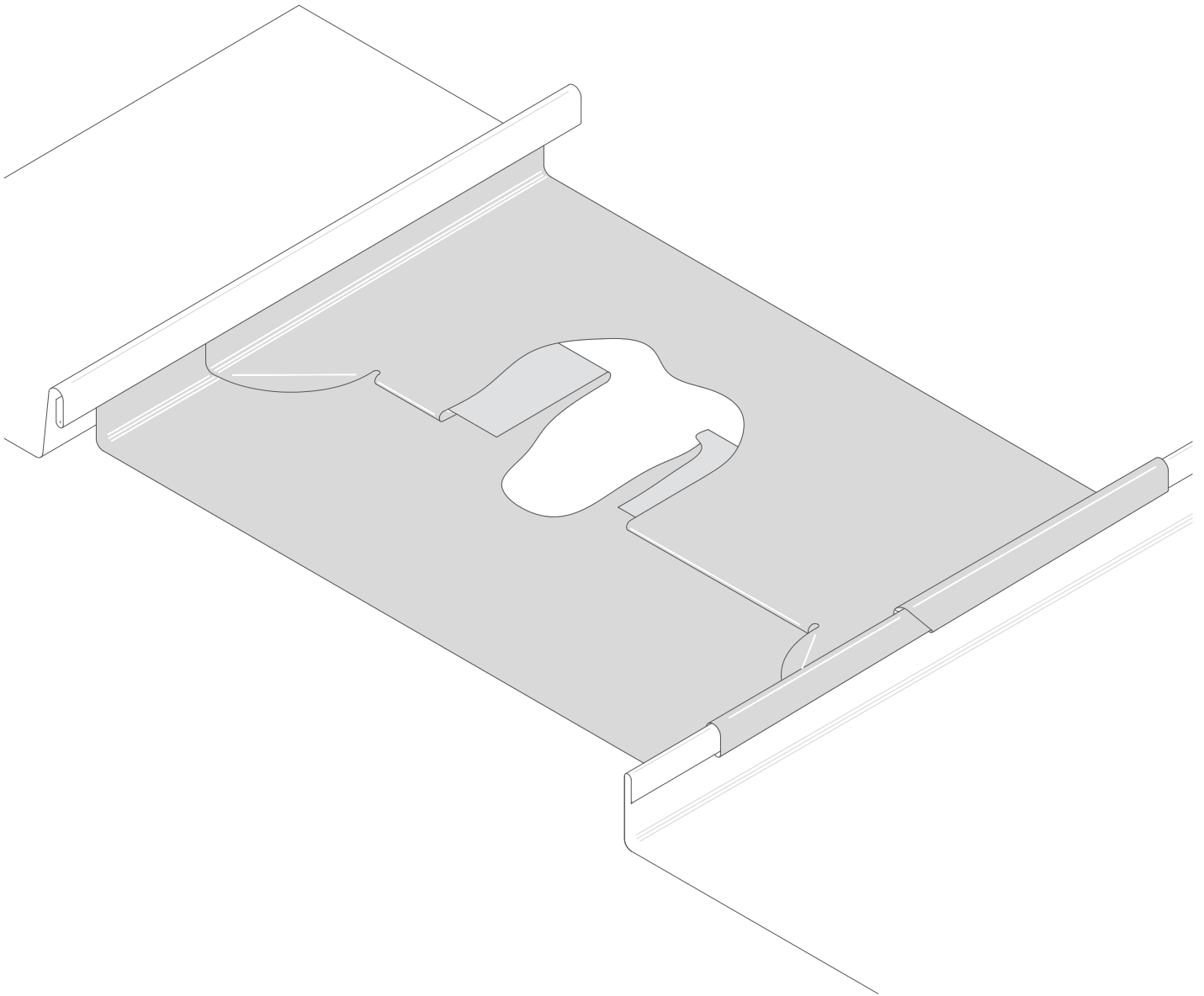

Scale 1/2

All dimensions are indicative unless specified on the drawing

- OK > 25°
- Alternative to DLSS I 2.1.01a

Single lock cross welt - DLSS I 2.1.1b



For correct printing, please make sure to set your printer to a 100% scale.

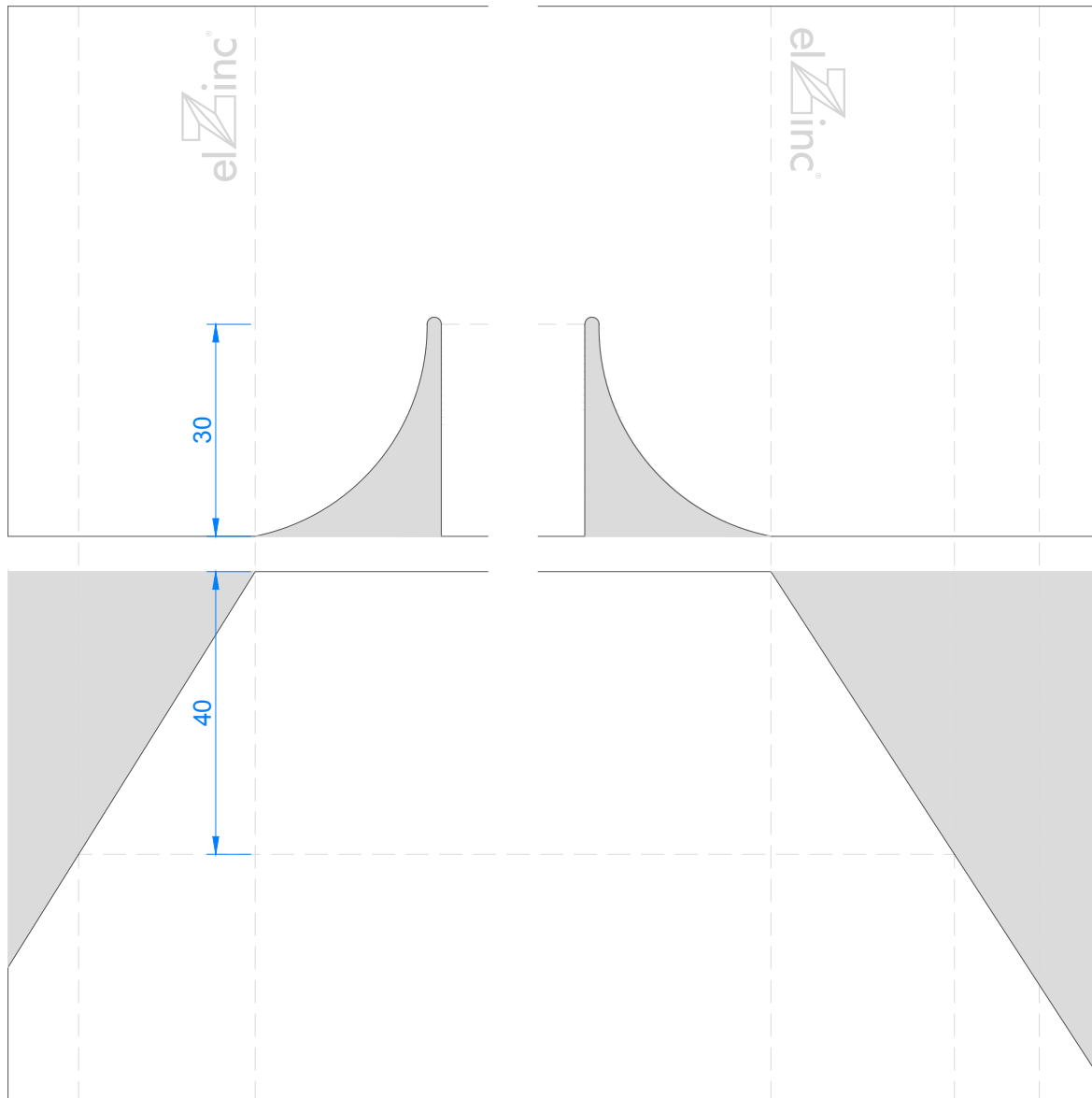

Scale 1/1

All dimensions are indicative unless specified on the drawing

- OK > 25°
- Alternative to DLSS I 2.1.01a

Single lock cross welt - DLSS I 2.1.1b

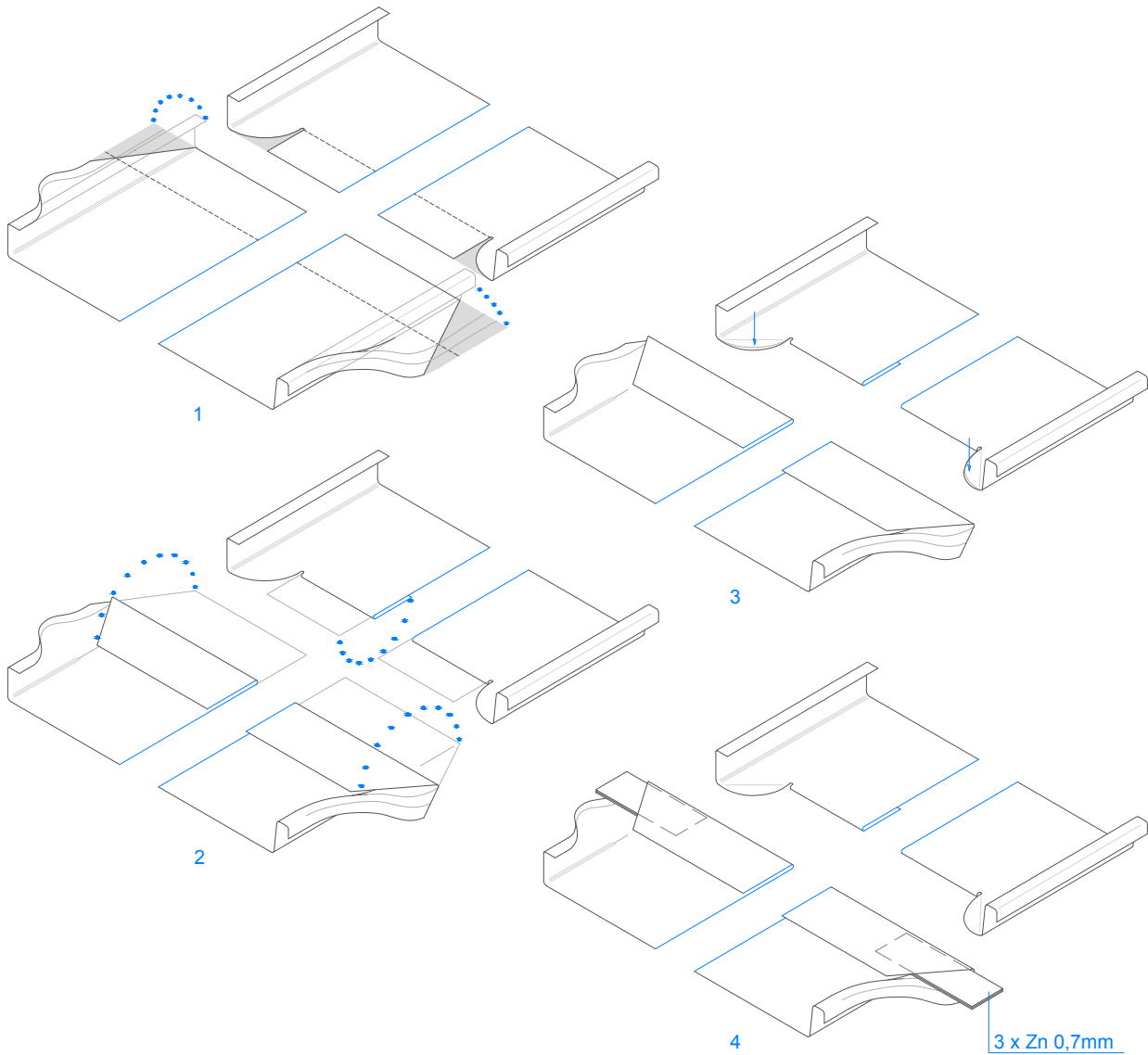

Scale 1/4

All dimensions are indicative unless specified on the drawing

· Step 2 preferably using folder

Step 1  +

Step 3 

Step 2  or 

Single lock cross welt - DLSS I 2.1.1b

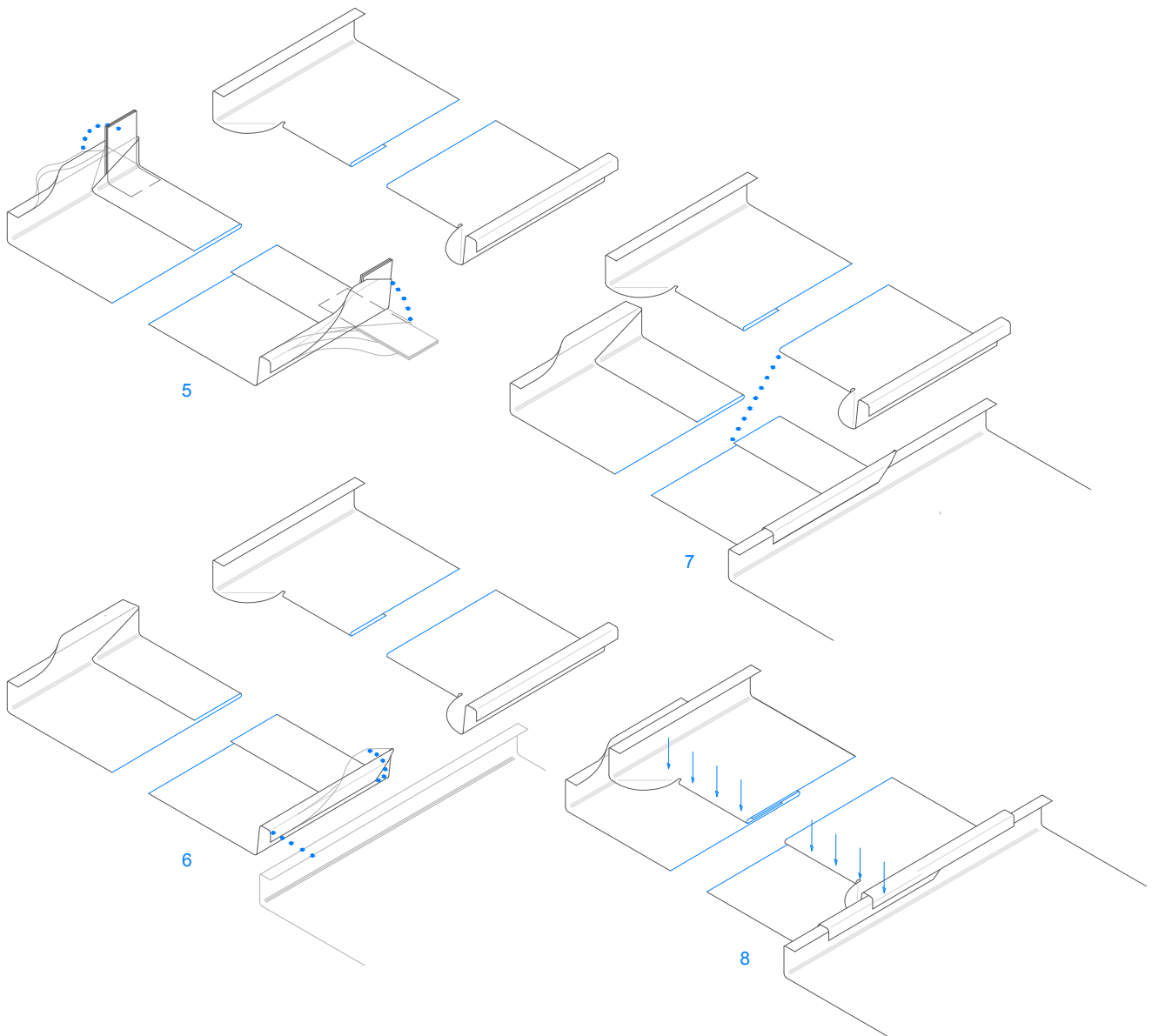

Scale 1/4

All dimensions are indicative unless specified on the drawing

· Step 5: Over-bend upstand then bend back to remove the 3 zinc spacers easily

Step 5



Step 8



Step 6



Single lock cross welt - DLSS I 2.1.1b

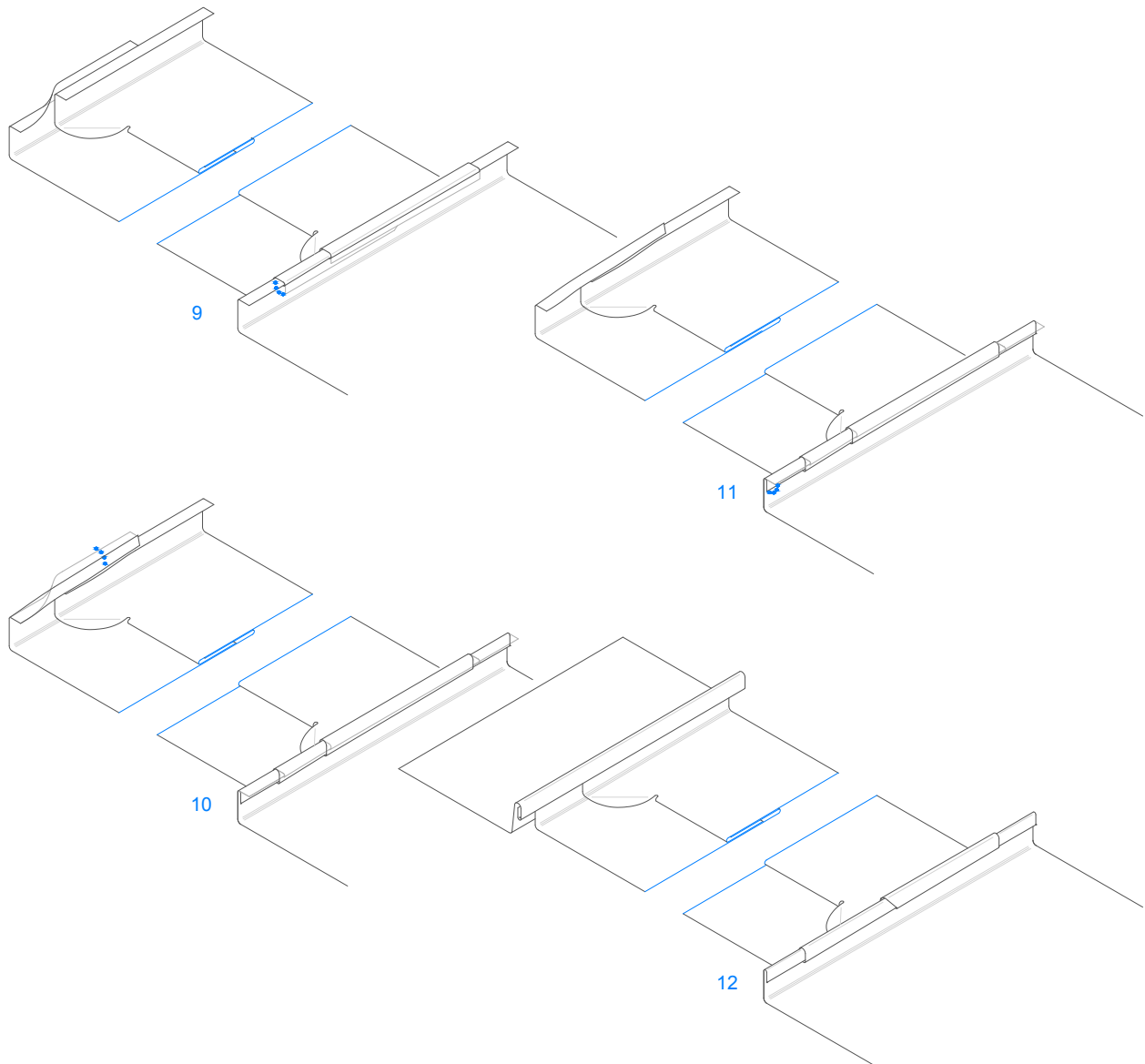

Scale 1/4

All dimensions are indicative unless specified on the drawing

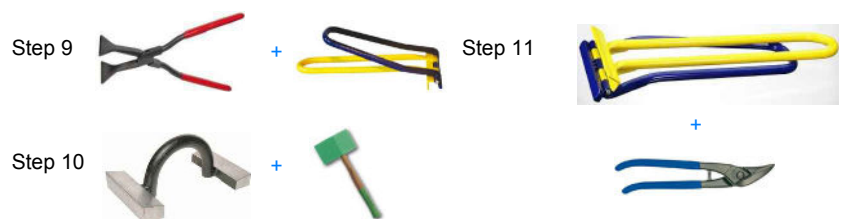

FACTORY AND HEAD OFFICE

ASTURIANA DE LAMINADOS, S.A.
Pol. Ind. de Villallana, Parcela 1
33695 Pola de Lena – Spain

T (0034) 98 567 60 00 / 98 410 60 00
F (0034) 98 549 32 02 / 98 569 20 00
elzinc@aslazinc.com

www.elzinc.es